

Environmental Treatment Facility & Water Use Reduction

Environmental Impact Assessment

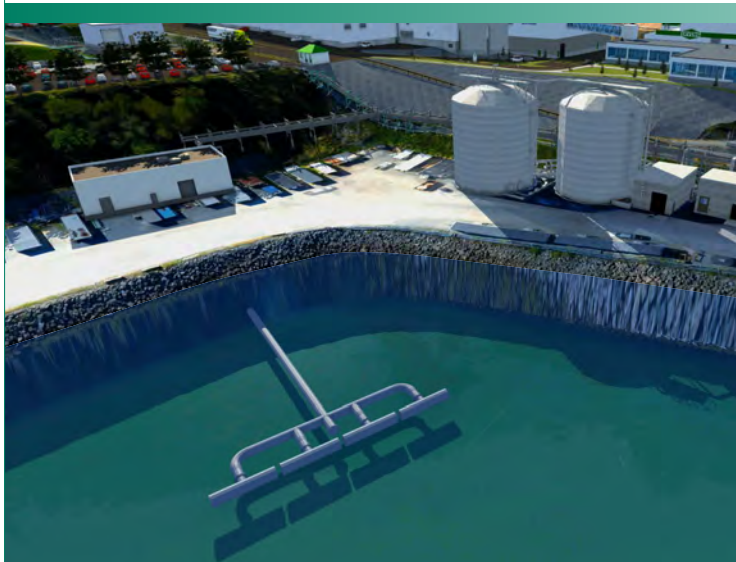

Irving Pulp & Paper, Limited

REVERSING FALLS MILL

Saint John, NEW BRUNSWICK

17 MARCH 2022



JOB FILE:	14972		
PROJECT TITLE:	Environmental Treatment Facility and Water Use Reduction Project Environmental Impact Assessment		
VERSION	ISSUANCE DATE	PREPARED BY	REVIEWED BY
0.9 (DRAFT)	14 January 2022	MDA	CC, AKD
Registration Document	17 March 2022	MDA	CC, AKD



Serving Our Clients' Needs First

This report was prepared for the sole use of the Client. The material and observations presented reflects Fundy Engineering & Consulting Ltd.'s opinion and best judgment based on the information available. Fundy Engineering & Consulting Ltd. accepts no liability or responsibility whatsoever for or in respect of any use of or reliance upon the material, observations, and / or opinions by any third-party or for any damages suffered by any third-party resulting from the use of this report.

PROFESSIONAL SEAL:



EXECUTIVE SUMMARY

The Irving Pulp & Paper (IPP) Reversing Falls Mill (*i.e.*, the Mill) near the mouth of the Saint John River is the anchor of the New Brunswick Forest Products Industry. The Mill has undergone numerous upgrades to become the world class pulp producing facility that it is today. With its modern, efficient, and sustainable environmental processes, the Mill currently produces a final process effluent that meets existing regulations.

As part of an on-going, long-term, multi-phase upgrade program to maintain the Mill's environmental sustainability and economic viability, IPP is proposing to install current best-available technology to build upon the existing pollution prevention strategy equipment at the Mill. This Environmental Impact Assessment (EIA) details the *Environmental Treatment Facility and Water Use Reduction* project (*i.e.*, the Project) planned for the Mill. The Project comprises installing and operating:

- an Environmental Treatment Facility (ETF): an onsite Moving Bed Biofilm Reactor (MBBR) to meet or exceed the existing Pulp and Paper Effluent Regulations (PPERs) [SOR / 92-269] under the *Fisheries Act* [R.S.C., 1985, c.F-14] and to accommodate any expected future changes to the PPERs; and
- a Water Use Reduction (WUR) system: a brackish water heat exchanger system that uses the cooling capacity of the Saint John River while coincidentally reducing the amount of freshwater drawn from the Spruce Lake Watershed by up to 50 %.



As per the Environmental Impact Assessment Regulation [87-83] of the New Brunswick *Clean Environment Act* [R.S.N.B. 1973, c C-6] the Project requires EIA review. EIA is a planning tool used by the proponent and regulatory authorities. The purpose of EIA is to identify and evaluate the potential impacts that the Project may have on the environment. Best-Management Practices (BMPs) are developed to mitigate any identified potential environmental impacts. The New Brunswick Department of the Environment and Local Government (NBDELG) oversees the EIA process that is conducted by a Technical Review Committee (TRC). The TRC is comprised of representatives from various local,

provincial, and federal government departments. The inclusive and participatory review process also includes First Nations engagement and public consultation.

IPP's engineering team has worked diligently to design a Project that yields substantial benefits. This was done by reviewing many technologies, selecting the leader, and then developing best-management operating practices. The existing pollution prevention equipment, in concert with the proposed Project, will place IPP among the global leaders in pulp and paper process water use and effluent treatment performance.

PROJECT BENEFITS



Several different onsite and offsite locations were considered for building and operating the ETF. Based on a detailed and prescriptive analysis, it was determined that the best location is the west side of the Mill site. That location has seen various uses over the years including rock quarrying and the storage of bark and wood chips. The WUR

component of the Project requires a brackish water intake. The most suitable location was determined to be the east side of the Mill site adjacent to and within Mill Cove.

Through the WUR component of the Project, cooling water drawn from the Spruce Lake Watershed will be collected, cooled using non-contact brackish water from the Saint John River, and then reused in the pulping process. This will ultimately reduce the overall quantity of freshwater required by nearly half and simultaneously reduce the Mill's total effluent volume by the same amount. Reducing the Mill's overall water use is critical to optimizing the ETF size and ensuring it can be located entirely onsite.

Annually, the Mill purchases about \$70 million in goods and services from New Brunswick suppliers and the approximately 480 direct employees working at the Mill contribute significantly to Saint John's community wellbeing and economy. Approximately 120 person years of work will be generated through construction of the ETF and at peak construction it is projected that up to 130 contractor employees will be onsite. The capital cost of this Project is pegged at \$150 million and it will ensure contributions to a healthy community and successful economy continue.

The Reversing Falls Mill's existing pollution prevention strategy sets it apart from other pulp mills throughout Canada. Under IPP's approach, which includes operating an MBBR, pulp-making materials are reduced, recovered, and reused at the Mill. Effluent treatment will be extended beyond pollution prevention through this Project. This will demonstrate further innovation in the Canadian pulp and paper industry.

A comprehensive assessment was completed for six different treatment technologies, including aerated stabilization basins and activated sludge treatment that are used for treating process effluent at other Canadian and European pulp and paper mills. Primary and secondary clarification coupled with MBBR technology was concluded to be the leading option for effluent treatment and will accommodate any future changes to the PPERs (*i.e.*, total suspended solids, biochemical oxygen demand, and chemical oxygen demand).

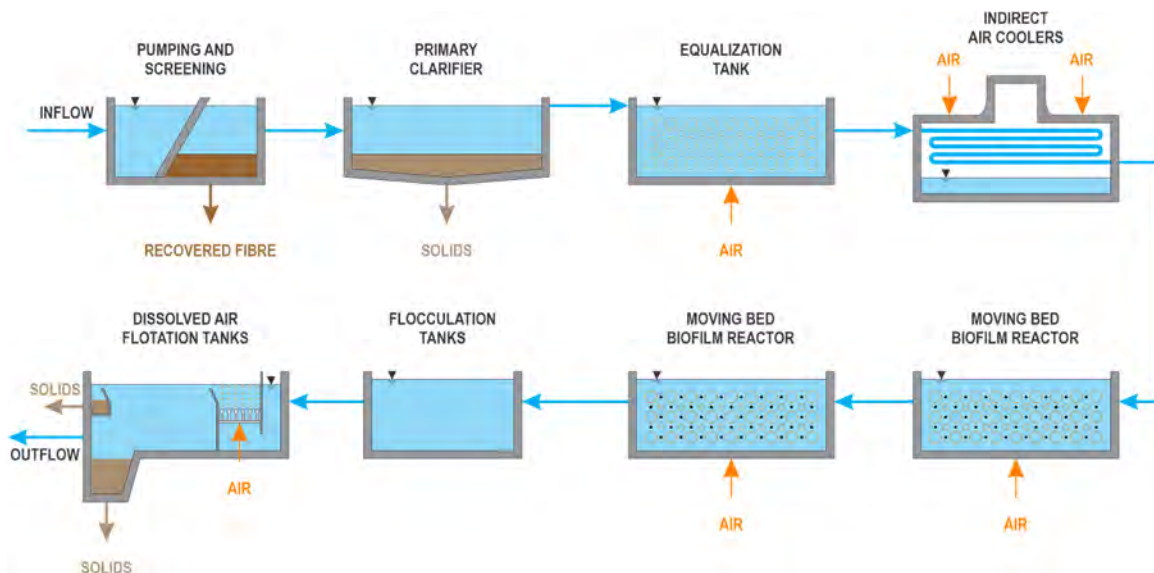

IPP's engineering team has also incorporated several best-in-class technologies within the ETF design. Those technologies will yield additional environmental benefits and will ensure IPP continues to be socially responsible and a good neighbour.



Fish impingement and entrainment will be nearly eliminated. The passive high-capacity, low velocity intake screens used for the WUR component of the Project will meet regulatory entry velocity guidelines for fish. The screens will also be equipped with an air-back-wash system to keep them clean to ensure that intake velocities remain within regulatory guidelines for fish protection.

Using brackish water from the Saint John River will allow process water obtained from the Spruce Lake Watershed to be cooled and reused within the Mill. It is estimated that this cooling process will yield insignificant changes to the temperature of the Saint John River at Mill Cove. Further, it is expected that there will be an overall reduction in warm water discharged to the Saint John River due to the reduced effluent flow.



Non-contact cooling technology will be used to cool the effluent prior to treatment. A combination of air and water will be used to cool the effluent as it is piped through one of two indirect air coolers. The indirect air coolers will include a circulation water management system, which will eliminate the risk of bacteria developing within them.

The indirect air coolers will also be equipped with a plume abatement system. This will involve the post heating of warmed cooling air to ensure it is not saturated with water vapour thereby minimizing the visible water vapour plumes from being produced.



The National Research Council of Canada conducted modelling and assessment of the existing and future effluent discharge from the Mill. The hydrodynamic modelling results show that the intensely turbulent flows through Reversing Falls rapidly disperse the effluent plume. Reducing the effluent volume and extent, combined with the enhanced effluent quality, will be environmentally beneficial to the Saint John River.

There is a negligible risk of odours being released from the Project. Large volumes of air added to the system will ensure that the solids do not go septic and create odour. There is no risk of odour from the indirect air coolers because there will be no direct contact between the cool air and process effluent. Continuous solids removal from the primary clarifier and dissolved air flotation tanks will further aid in odour abatement. All solids handling will be conducted indoors and air from those spaces will be tempered before release to eliminate odours.



There is little risk of loud sounds being emitted during Project operation. Equipment that will generate loud sounds, such as air blowers, pumps, and air compressors, will be located inside buildings. Walls of the rooms in those buildings will be insulated to help mitigate the emission of loud sounds.

The majority of the existing landscape will remain and minimal new infrastructure will be visible from residential neighbours in Milford. A landscaped berm will be established between the ETF and Milford Road. The WUR pumphouse building and associated infrastructure will be located in a topographically low area of the Mill site that is not visible by residents in Milford.



Through this Project, operators will have the ability to divert process flows from the Mill that are outside the design tolerances of the ETF. This flow separation will be achieved by including a diversion tank. Flow will only be directed back to the treatment tanks once the ETF is capable of reintegrating the effluent into the overall treatment process.

There is a potential to offset the greenhouse gas emissions associated with purchased electricity. During operation, fibre and solids will be continuously removed from the ETF. There may be opportunities to burn that material in the onsite biomass boiler to generate electricity, thus offsetting greenhouse gas emissions.



This EIA document provides a detailed Project description and narrative on the baseline environment. Components of the existing environment that are described include the physio-chemical environment, the biological environment, and the socio-economic environment. The baseline environmental data were overlain by five Project stages (*i.e.*, environmental permitting, construction, operation and maintenance, decommissioning, and mishaps, errors, and / or unforeseen events) to identify potential environmental interactions. Based on that process, 12 Valued Environmental Components (VECs) were identified. The VECs that were assessed in detail within the EIA include:

- physio-chemical environment:
 - air quality;
 - sound emissions;
 - surface water quality and quantity; and
 - groundwater quality and quantity;
- biological environment:
 - terrestrial flora and fauna;
 - aquatic flora and fauna; and
- socio-economic environment:
 - labour and economy;
 - archaeological and cultural resources;
 - transportation network;
 - aesthetics;
 - recreation and tourism; and
 - health and safety.

A visual impact assessment process similar to a traffic light was used for characterizing the potential environmental interactions. All told, 174 specific possible environmental interactions were assessed. Of those, 38 % were assigned green lights, 41 % were given yellow lights, and 21 % yielded no changes. Red lights (*i.e.*, not favourable or major

impacts) were not assigned to any of the potential interactions. The ultimate Project impact assessment, which is based on the summation of all possible environmental interactions for the 12 VECs, produced a yellow light. The ultimate outcome of this Project will be environmentally beneficial and should proceed as detailed within this EIA document.

VEC ASSESSMENT

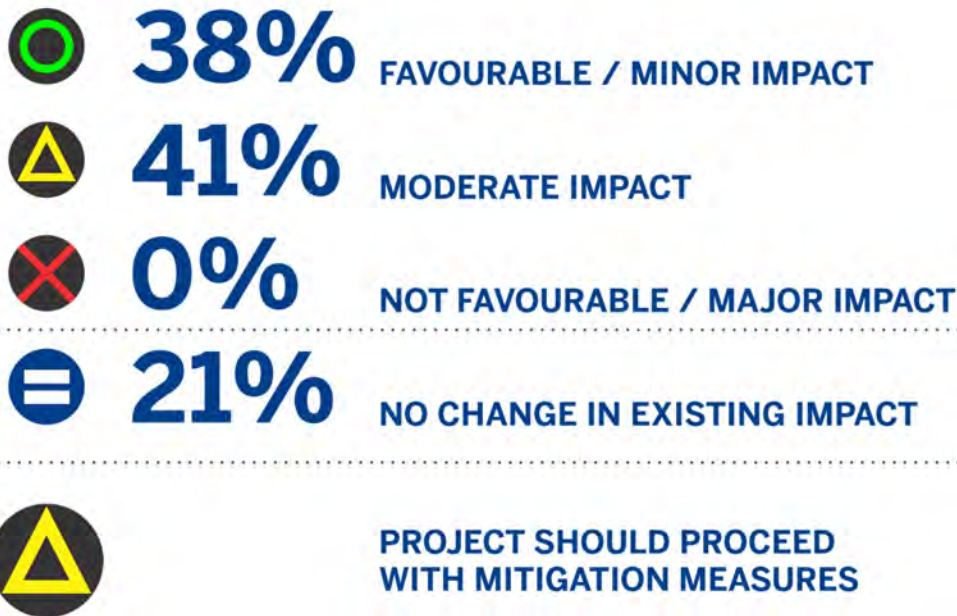

A Project-specific Environmental Protection Plan (EPP) will be developed to mitigate the potential impacts identified. The EPP will prescribe BMPs that will be used throughout Project construction and during operation and maintenance to safeguard the environment. The Project-specific EPP will be a dynamic document used by Project personnel in the field and at the corporate level for ensuring commitments made in the EIA are implemented and monitored.

The EIA process is an open and transparent process that involves First Nations engagement and public consultation. The process assures individuals and / or groups that may be potentially affected by the Project are made aware of the registration, are able to obtain information on the Project, and are able to express any and / or all concerns they may have.

IPP began engaging with First Nations in October 2020. Through First Nations engagement, items raised included the potential to discover archaeological resources during site development and temperature changes to the Saint John River after the Project is in operation. To protect archaeological resources, IPP will be engaging the Wolastoqey Nation in New Brunswick to train contractors and employees on their *Accidental Discovery of Archaeological Resources Protocol*. This Project will not significantly change the temperature of Mill Cove.

This EIA document is available for public comment until 20 April 2022. As a good environmental steward and neighbour, IPP intends to hold a voluntary public open house while adhering to corporate and Public Health COVID-19 protocols. Tentatively, the open house will be conducted near the Mill at a date and location yet to be determined. Visual aids will be on display and attendees will have the opportunity to discuss the Project with IPP staff. Attendees will also be able to submit written questions during the open house for inclusion in a Public Consultation report that will be submitted to the NBDELG.

Comments, questions, and concerns regarding the EIA document can also be forwarded to the Environmental Consultant:

Dr. Matt Alexander, *P.Geo., FGC, EP*
Fundy Engineering & Consulting Ltd.
27 Wellington Row
Saint John, New Brunswick
E2L 3H4

📞 506.635.1566
📠 506.635.0206
🌐 www.fundyeng.com
✉ matt.alexander@fundyeng.com

CONTENTS

EXECUTIVE SUMMARY	i
LIST OF TABLES.....	xvi
LIST OF FIGURES.....	xxii
LIST OF ACRONYMS.....	xxviii
1.0 Proponent.....	1
1.1 Proponent Name.....	1
1.2 Proponent Address	1
1.3 Proponent Contact.....	1
1.4 Principal Contact for Purposes of Environmental Impact Assessment.....	1
1.5 Property Ownership	2
2.0 Project Description	4
2.1 Project Name	4
2.2 Project Overview.....	4
2.2.1 Environmental Treatment Facility	5
2.2.2 Water Use Reduction	6
2.2.3 Project Benefits	7
2.3 Purpose of this Environmental Impact Assessment	8
2.4 Project Purpose / Rationale / Need	8
2.5 Project Location	13
2.6 Project Alternatives.....	14
2.6.1 Null Alternative	14
2.6.2 Project Location.....	15
2.6.3 Treatment Technology.....	18
2.6.3.1 Aerated Stabilization Basin (ASB).....	19
2.6.3.2 Activated Sludge Treatment (AST).....	19
2.6.3.3 Moving Bed Biofilm Reactor (MBBR)	20
2.6.3.4 Nutrient Limited Biological Activated Sludge (NLBAS).....	21
2.6.3.5 Sequential Biological Reactors (SBR).....	22
2.6.3.6 Membrane Biological Reactor (MBR).....	22
2.6.3.7 Treatment Technology Review, Assessment, and Selection	23
2.6.3.7.1 Site Visits	23
2.6.3.7.2 Technology Comparison	24
2.6.3.7.3 Needs and Wants Assessment	25
2.6.3.7.4 Pilot Plants	27
2.6.3.7.5 Technology Selected.....	28

2.7	Project Details.....	28
2.7.1	Environmental Treatment Facility.....	29
2.7.1.1	Design Parameters.....	32
2.7.1.1.1	Flows and Loading.....	32
2.7.1.1.2	Regulatory Discharge Limits and Performance Discharge	32
2.7.1.2	Mill Process Tie-Ins	34
2.7.1.2.1	West Side Lift Station.....	34
2.7.1.2.2	Piping.....	34
2.7.1.3	Pre-Treatment	34
2.7.1.3.1	Screening.....	34
2.7.1.4	Primary Treatment.....	35
2.7.1.4.1	Primary Gravity Clarifier.....	35
2.7.1.4.2	Equalization Tank.....	37
2.7.1.4.2.1	pH Correction.....	37
2.7.1.4.3	Indirect Air Coolers.....	38
2.7.1.4.4	Diversion Tank	39
2.7.1.5	Biological Treatment.....	40
2.7.1.5.1	Moving Bed Biofilm Reactor (MBBR).....	40
2.7.1.5.2	Nutrient Adjustment.....	41
2.7.1.5.2.1	Nitrogen.....	41
2.7.1.5.2.2	Phosphorous.....	42
2.7.1.6	Secondary Clarification	43
2.7.1.6.1	Dissolved Air Flotation (DAF).....	43
2.7.1.6.1.1	Polymer Addition.....	44
2.7.1.7	Solids Treatment	44
2.7.1.7.1	Solids Production	44
2.7.1.7.2	Solids Tanks.....	45
2.7.1.7.2.1	Primary Solids Tank.....	45
2.7.1.7.2.2	Secondary Solids Tank.....	45
2.7.1.7.2.3	Solids Blending Tank	46
2.7.1.7.2.4	Centrate Tank	46
2.7.1.7.3	Dewatering System	46
2.7.1.7.3.1	Centrifuges.....	46
2.7.1.7.3.2	Presses	46
2.7.1.7.3.3	Polymer Addition.....	46

2.7.1.7.4	Solids Disposal.....	47
2.7.1.8	Process Building.....	47
2.7.1.8.1	Utilities and Ancillary Equipment.....	47
2.7.1.8.1.1	Warm Raw Water.....	47
2.7.1.8.1.2	Seal Water.....	47
2.7.1.8.1.3	Potable Water.....	48
2.7.1.8.1.4	Hot Water.....	48
2.7.1.8.1.5	Sanitary Wastewater Holding Tank.....	48
2.7.1.8.1.6	Compressed Air.....	48
2.7.1.8.1.7	Power and Back-Up Power.....	48
2.7.1.8.1.8	Lighting.....	48
2.7.1.8.1.9	Fire Prevention and Life Safety Equipment.....	49
2.7.1.8.1.10	Design Standards.....	49
2.7.1.9	Landscaped Berm.....	50
2.7.1.10	Environmental Treatment Facility Summary.....	51
2.7.2	Water Use Reduction.....	52
2.7.2.1	Cool Water Intake.....	54
2.7.2.2	Pumphouse.....	57
2.7.2.3	Pipeline and Pipe Bridge.....	58
2.7.2.4	Heat Exchangers.....	58
2.7.2.5	Warm Water Discharge.....	59
2.7.2.6	Utilities and Ancillary Equipment.....	60
2.7.2.6.1	Lighting.....	60
2.7.2.6.2	Design Standards.....	60
2.7.2.7	Water Use Reduction Summary.....	60
2.8	Project Stages.....	61
2.8.1	Stage I - Project Environmental Permitting, Monitoring, and Compliance.....	61
2.8.1.1	Existing Approvals.....	62
2.8.2	Stage II - Project Construction.....	62
2.8.2.1	Temporary Infrastructure and Supporting Facilities.....	64
2.8.2.2	Services and Excavations.....	65
2.8.2.3	Structural Foundations.....	66
2.8.2.4	Work Hours.....	66
2.8.2.5	Labour.....	66
2.8.2.6	Site Access.....	67

2.8.2.7	Traffic	67
2.8.2.8	Safety	68
2.8.2.9	Commissioning.....	68
2.8.3	Stage III - Project Operation and Maintenance	69
2.8.4	Stage IV - Project Decommissioning	70
2.8.5	Stage V - Mishaps, Errors, and / or Unforeseen Events.....	70
2.9	Project Schedule.....	70
3.0	Description of the Existing / Baseline Environment.....	71
3.1	Physio-Chemical Environment.....	71
3.1.1	Climate	71
3.1.2	Air Quality	73
3.1.2.1	Objectives.....	73
3.1.2.2	Monitoring.....	74
3.1.2.3	National Pollutant Release Inventory Reporting.....	76
3.1.2.4	Greenhouse Gas Reporting Program.....	78
3.1.3	Sound Levels.....	82
3.1.4	Topography	82
3.1.5	Hydrology	84
3.1.6	Geology	87
3.1.6.1	Bedrock	87
3.1.6.2	Surficial.....	89
3.1.7	Hydrogeology	91
3.1.8	Hydrography.....	93
3.2	Biological Environment	95
3.2.1	Federal Species At Risk	95
3.2.1.1	Snapshots of Federal Species At Risk Locally Present	99
3.2.1.2	Snapshots of Bats	102
3.2.2	Provincial Species At Risk.....	103
3.2.2.1	Snapshots of Provincial Species at Risk Locally Present	108
3.2.3	Location-Sensitive Species	110
3.2.4	Other Locally Observed Species	111
3.2.5	Environmentally Significant and Managed Areas	122
3.3	Socio-Economic Environment.....	126
3.3.1	Population and Demographics	126
3.3.2	Economy and Labour	126
3.3.3	Archaeological and Cultural Features	130

3.3.4	Traditional Uses by First Nations.....	132
3.3.5	Historical Land-Use	135
3.3.6	Health and Safety	143
3.3.7	Transportation Network and Links.....	143
3.3.8	Municipal Services and Infrastructure	146
3.3.9	Aesthetics	148
3.3.10	Recreation and Tourism	149
4.0	Potential Environmental Impacts and Mitigation	151
4.1	Environmental Impact Assessment Purpose	151
4.1.1	Guiding Principles.....	153
4.2	Environmental Impact Avoidance	153
4.3	Overview of Valued Environmental Component Analysis.....	155
4.3.1	Project Interactions / Scoping.....	155
4.3.1.1	VEC Matrix	156
4.3.2	Impact Assessment Methodology.....	157
4.3.2.1	Conceivable Impacts and Pathways	158
4.3.2.2	Project Impact Assessment.....	159
4.3.2.2.1	Impact Assessment Scoring Matrices	160
4.3.2.3	Impact Mitigation	162
4.3.2.4	Residual Impact Assessment	163
4.4	Potential Project Impacts on the Environment.....	163
4.4.1	Valued Environmental Components Assessed	163
4.4.2	Physio-Chemical Environment	163
4.4.2.1	Air Quality.....	163
4.4.2.1.1	Conceivable Impacts and Pathways	164
4.4.2.1.2	Potential Impacts.....	165
4.4.2.1.3	Proposed Mitigation	167
4.4.2.1.4	Potential Post-Mitigation Residual Impacts	168
4.4.2.2	Sound Emissions.....	168
4.4.2.2.1	Conceivable Impacts and Pathways	170
4.4.2.2.2	Potential Impacts.....	171
4.4.2.2.3	Proposed Mitigation	171
4.4.2.2.4	Potential Post-Mitigation Residual Impacts	173
4.4.2.3	Surface Water Quality and Quantity.....	173
4.4.2.3.1	Conceivable Impacts and Pathways	173
4.4.2.3.2	Potential Impacts.....	175

4.4.2.3.3	Proposed Mitigation	182
4.4.2.3.4	Potential Post-Mitigation Residual and Cumulative Impacts.....	184
4.4.2.4	Groundwater Quality and Quantity	184
4.4.2.4.1	Conceivable Impacts and Pathways	184
4.4.2.4.2	Potential Impacts.....	186
4.4.2.4.3	Proposed Mitigation	186
4.4.2.4.4	Potential Post-Mitigation Residual Impacts.....	188
4.4.3	Biological Environment	194
4.4.3.1	Terrestrial Flora and Fauna.....	194
4.4.3.1.1	Conceivable Impacts and Pathways	194
4.4.3.1.2	Potential Impacts.....	196
4.4.3.1.3	Proposed Mitigation	196
4.4.3.1.4	Potential Post-Mitigation Residual Impacts.....	198
4.4.3.2	Aquatic Flora and Fauna	198
4.4.3.2.1	Conceivable Impacts and Pathways	198
4.4.3.2.2	Potential Impacts.....	201
4.4.3.2.3	Proposed Mitigation	202
4.4.3.2.4	Potential Post-Mitigation Residual and Cumulative Impacts.....	203
4.4.4	Socio-Economic Environment	207
4.4.4.1	Labour and Economy	207
4.4.4.1.1	Conceivable Impacts and Pathways	207
4.4.4.1.2	Potential Impacts.....	208
4.4.4.1.3	Proposed Mitigation	208
4.4.4.1.4	Potential Post-Mitigation Residual Impacts.....	209
4.4.4.2	Archaeological and Cultural Resources	209
4.4.4.2.1	Conceivable Impacts and Pathways	209
4.4.4.2.2	Potential Impacts.....	210
4.4.4.2.3	Proposed Mitigation	211
4.4.4.2.4	Potential Post-Mitigation Residual Impacts.....	211
4.4.4.3	Transportation Network.....	211
4.4.4.3.1	Conceivable Impacts and Pathways	212
4.4.4.3.2	Potential Impacts.....	213
4.4.4.3.3	Proposed Mitigation	213
4.4.4.3.4	Potential Post-Mitigation Residual and Cumulative Impacts.....	214
4.4.4.4	Aesthetics.....	214
4.4.4.4.1	Conceivable Impacts and Pathways	216

4.4.4.4.2	Potential Impacts.....	216
4.4.4.4.3	Proposed Mitigation	222
4.4.4.4.4	Potential Post-Mitigation Residual Impacts	223
4.4.4.5	Recreation and Tourism	223
4.4.4.5.1	Conceivable Impacts and Pathways	223
4.4.4.5.2	Potential Impacts.....	223
4.4.4.5.3	Proposed Mitigation	224
4.4.4.5.4	Potential Post-Mitigation Residual Impacts.....	224
4.4.4.6	Health and Safety.....	224
4.4.4.6.1	Conceivable Impacts and Pathways	224
4.4.4.6.2	Potential Impacts.....	226
4.4.4.6.3	Proposed Mitigation	226
4.4.4.6.4	Potential Post-Mitigation Residual Impacts.....	227
4.4.5	Summary of Potential Environmental Impacts.....	234
4.5	Potential Environment Impacts on the Project.....	235
4.5.1	Notes on Climate Change	235
4.5.2	Notes on Extreme Weather	237
4.5.3	Temperature	239
4.5.4	Precipitation.....	240
4.5.5	Winds.....	243
4.5.6	Wet and Dry Acid Deposition.....	244
4.5.7	Seismic Activity.....	246
4.5.8	Sea Level Rise	250
4.5.9	Summary	254
4.6	Project-Specific Environmental Protection Plan	255
5.0	First Nations Engagement and Public Consultation	256
5.1	Parties Included.....	256
5.1.1	First Nations	256
5.1.2	Local Residents and Stakeholders	259
5.1.3	Regulatory Agencies	259
5.2	Pre-Registration Engagement and Consultation	259
5.2.1	New Brunswick Department of Aboriginal Affairs	259
5.2.2	First Nations	259
5.2.3	New Brunswick Department of the Environment and Local Government	260
5.2.3.1	21 September 2021	260
5.2.3.2	6 October 2021.....	261

5.2.3.3	2 February 2022	261
5.3	Registration Engagement and Consultation	262
5.3.1	Step 1: Direct Communication with Elected Officials and Service Groups 263	
5.3.2	Step 2: Direct Written Communication with Nearby Residents	264
5.3.3	Step 3: Notifications on the NBDELG Website and at the Head Office ..	267
5.3.4	Step 4: Documentation Availability with Stakeholder and NBDELG Offices 267	
5.3.5	Step 5: Public Notice Announcement	267
5.3.6	Step 6: Local Area Availability of the Registered Document	268
5.3.7	Step 7: Open House and / or Public Meeting	269
5.3.8	Step 8: Documentation of Public Consultation Activities	269
6.0	Project Approvals	270
6.1	Federal Approvals.....	272
6.1.1	Fisheries Act Authorization.....	272
6.1.2	Navigation Protection Permit	273
6.1.3	Navigational Warning	273
6.1.4	Harbour Master Authorization.....	274
6.2	Provincial Approvals	275
6.2.1	Environmental Impact Assessment Approval	275
6.2.2	Environmental Protection Plan	276
6.2.3	Watercourse and Wetland Alteration Permit	277
6.2.4	Approval To Construct.....	278
6.2.5	Approval To Operate	279
6.2.5.1	Water Quality.....	279
6.2.6	Vehicle Dimensions and Mass and Special Permit Fees	279
6.2.7	Electrical Plan Approval and Wiring Permit	280
6.3	Municipal Approvals.....	281
6.3.1	Re-Zoning.....	281
6.3.2	Building Permit	282
6.3.3	Excavation Permit.....	282
7.0	Funding	284
8.0	Signatures	285
9.0	References	286
10.0	Glossary	294
11.0	Report Disclaimers and Disclosures	304

APPENDICES

APPENDIX I:	Service New Brunswick Property Information
APPENDIX II:	Reversing Falls Mill's Approvals To Operate
APPENDIX III:	Irving Pulp & Paper's Pollution Prevention Strategy
APPENDIX IV:	Environmental Treatment Facility Preliminary Design
APPENDIX V:	Potential Equipment Product Brochures
APPENDIX VI:	Geotechnical Investigation
APPENDIX VII:	Online Well Log System Data Report
APPENDIX VIII:	Atlantic Canada Conservation Data Centre Report
APPENDIX IX:	Valued Environmental Component Impact Assessment Matrices
APPENDIX X:	Greenhouse Gas Emissions Estimates
APPENDIX XI:	River Temperature Monitoring Program
APPENDIX XII:	Preliminary Effluent Modelling
APPENDIX XIII:	First Nations Engagement Logs

TABLES

Table 1. List of properties in Saint John, New Brunswick that comprise the Reversing Falls Mill site.	2
Table 2. Current and proposed pulp and paper effluent regulation limits under the federal <i>Fisheries Act</i> [R.S.C. 1985, c. F-14] [ECCC, 2019].	12
Table 3. Summary of the potential environmental constraints for locations evaluated for siting the environmental treatment facility proposed for the Reversing Falls Mill in Saint John, New Brunswick.	16
Table 4. Industry advantages and disadvantages of the effluent treatment technologies considered for the Reversing Falls Mill in Saint John, New Brunswick.	24
Table 5. Comparison of effluent treatment technologies considered for the Reversing Falls Mill in Saint John, New Brunswick.	26
Table 6. Tentative elevations for the main components of the environmental treatment facility proposed for the Reversing Falls Mill in Saint John, New Brunswick.	30
Table 7. Flow and loading criteria used for designing the environmental treatment facility at the Reversing Falls Mill in Saint John, New Brunswick. These predicted feed values are based on four years of data collected at the Mill from 2017 to 2020.	32
Table 8. Current effluent discharge from Reversing Falls Mill in Saint John, New Brunswick compared to the current regulatory discharge limits. Also included are the predicted effluent discharge criteria for the environmental treatment facility and the proposed modernized regulatory discharge limits.	33

Table 9. Preliminary operational performance of the primary gravity clarifier proposed for the environmental treatment facility at the Reversing Falls Mill in Saint John, New Brunswick.....	36
Table 10. Preliminary operational performance of the two AnoxKaldnes™ moving bed biofilm reactors proposed for the environmental treatment facility at the Reversing Falls Mill in Saint John, New Brunswick.....	41
Table 11. Estimates for nitrogen addition to the effluent in the form of a 40 % W / W urea solution at the Reversing Falls Mill in Saint John, New Brunswick.	42
Table 12. Estimates for phosphorous addition to the effluent in the form of a 75 % W / W phosphoric acid solution at the Reversing Falls Mill in Saint John, New Brunswick.....	42
Table 13. Expected daily solids volumes and dryness from primary and secondary clarification for the environmental treatment facility at the Reversing Falls Mill in Saint John, New Brunswick.....	45
Table 14. Jurisdictional organizations and contractor’s codes of reference for the environmental treatment facility at the Reversing Falls Mill in Saint John, New Brunswick.....	49
Table 15. Cooling performance of each heat exchanger in summer and winter as modelled for water use reduction at the Reversing Falls Mill in Saint John, New Brunswick.....	59
Table 16. Summary of the main construction materials for the environmental treatment facility and water use reduction project proposed for the Reversing Falls Mill in Saint John, New Brunswick.	62
Table 17. Typical list of heavy equipment anticipated for use during construction of the environmental treatment facility and water use reduction project proposed for the Reversing Falls Mill in Saint John, New Brunswick.....	63
Table 18. New Brunswick ambient air quality objectives as per the New Brunswick <i>Clean Air Act</i> [S.N.B. 1997, c. C-5.2].....	74
Table 19. Air emissions data, circa 2019, for facilities in greater Saint John that reported to Environment Canada’s National Pollutant Release Inventory tracking database.	78
Table 20. Provincial and territorial, national, and global greenhouse gas emissions data for five year increments since 1990 and for the last three years with available data. Data from <i>ECCC</i> [2021b] and <i>WRI</i> [2021].	80
Table 21. River stages at Saint John, New Brunswick for the Saint John River.	86
Table 22. Tide levels, relative to chart datum, for Saint John Harbour, New Brunswick.....	86
Table 23. Descriptions of the bedrock geology in the vicinity of the Reversing Falls Mill at the mouth of the Saint John River in Saint John, New Brunswick.	87
Table 24. Descriptions of the surficial geology in the vicinity of the Reversing Falls Mill at the mouth of the Saint John River in Saint John, New Brunswick.	89

Table 25. Summary of the groundwater well records within a 1 km radius of the Reversing Falls Mill at the mouth of the Saint John River in Saint John, New Brunswick.....	93
Table 26. Terrestrial and aquatic flora and fauna listed as being species at risk under the fSARA and by the COSEWIC that could potentially be affected by the proposed Project at the Reversing Falls Mill in Saint John, New Brunswick.	95
Table 27. Terrestrial and aquatic flora and fauna listed as being at risk in New Brunswick under the pSARA.....	103
Table 28. List of provincially ranked flora and fauna identified by the ACCDC as being observed within 5 km of the Reversing Falls Mill in Saint John, New Brunswick.	111
Table 29. The Atlantic Canada Conservation Data Centre’s Sub-national (<i>i.e.</i> , provincial) rarity rank (S-rank) of species and S-rank definitions.....	116
Table 30. Fish species observed within the Lower Saint John River (<i>i.e.</i> , from Oak Point to Reversing Falls) as reported in <i>Kidd et al.</i> [2011].....	120
Table 31. Species that have been observed in areas of the Lower Saint John River in close proximity to the proposed Project at Reversing Falls in Saint John, New Brunswick. Refer to Figure 64.....	122
Table 32. 2016 Statistics Canada labour force employment by sector for Saint John, New Brunswick.....	128
Table 33. Southwest New Brunswick Statistics Canada population data by County and Census Year.	129
Table 34. Employment by occupational category for the southwest economic region of New Brunswick in 2017.....	129
Table 35. Employment by sector for the southwest economic region of New Brunswick in 2017.....	130
Table 36. Historical timeline of the use of the Union Point lands, now known as the Reversing Falls Mill in Saint John, New Brunswick.....	135
Table 37. The guiding principles of environmental impact assessment. After <i>Sadler</i> [1996] and <i>IAIA & IEMA</i> [1999].	153
Table 38. Project stages of the proposed environmental treatment facility and water use reduction project at the Reversing Falls Mill in Saint John, New Brunswick. Included are the activities associated with each stage and whether or not there is an interaction with the environment.	156
Table 39. Assessment of potential interactions of various stages of the proposed environmental treatment facility and water use reduction project at the Reversing Falls Mill in Saint John, New Brunswick and the environment. Check marks indicate that there is potential for interaction and requires further assessment.	156
Table 40. Fundy Engineering’s Valued Environment Component Assessment visual coding method, which is analogous to a traffic light.....	159
Table 41. Environmental impact characterization used in the assessment of the Valued Environmental Components and their sub-components.	161

Table 42. Impact categories, ranks, and assigned importance scores used in the assessment of significant environmental impacts.	162
Table 43. Assessment scores, impact significance, and symbols used in the assessment of significant environmental impacts.	162
Table 44. The type of cause-effect relationships that are possible and the mechanisms by which stressors could ultimately lead to impacts on air quality during various activities associated with the proposed environmental treatment facility and water use reduction project at the Reversing Falls Mill in Saint John, New Brunswick.	164
Table 45. The type of cause-effect relationships that are possible and the mechanisms by which stressors could ultimately lead to impacts on the sound environment during various activities associated with the proposed environmental treatment facility and water use reduction project at the Reversing Falls Mill in Saint John, New Brunswick.	170
Table 46. The type of cause-effect relationships that are possible and the mechanisms by which stressors could ultimately lead to impacts on the surface water environment during various activities associated with the proposed environmental treatment facility and water use reduction project at the Reversing Falls Mill in Saint John, New Brunswick.	173
Table 47. Estimated summer and winter mixed temperature of the Saint John River at the point of the warm water discharge from the Reversing Falls Mill in Saint John, New Brunswick.	175
Table 48. The type of cause-effect relationships that are possible and the mechanisms by which stressors could ultimately lead to impacts on the groundwater environment during various activities associated with the proposed environmental treatment facility and water use reduction project at the Reversing Falls Mill in Saint John, New Brunswick.	185
Table 49. Assessment of potential impacts on air quality of the proposed environmental treatment facility and water use reduction project at the Reversing Falls Mill in Saint John, New Brunswick.	189
Table 50. Assessment of potential impacts on sound emissions of the proposed environmental treatment facility and water use reduction project at the Reversing Falls Mill in Saint John, New Brunswick.	190
Table 51. Assessment of potential impacts on surface water quantity and quality of the proposed environmental treatment facility and water use reduction project at the Reversing Falls Mill in Saint John, New Brunswick.	191
Table 52. Assessment of potential impacts on groundwater quantity and quality of the proposed environmental treatment facility and water use reduction project at the Reversing Falls Mill in Saint John, New Brunswick.	193
Table 53. The type of cause-effect relationships that are possible and the mechanisms by which stressors could ultimately lead to impacts on terrestrial flora and fauna during various activities associated with the proposed environmental treatment facility and water use reduction project at the Reversing Falls Mill in Saint John, New Brunswick.	194

Table 54. The type of cause-effect relationships that are possible and the mechanisms by which stressors could ultimately lead to impacts on aquatic flora and fauna during various activities associated with the proposed environmental treatment facility and water use reduction project at the Reversing Falls Mill in Saint John, New Brunswick.....	198
Table 55. Assessment of potential impacts on terrestrial flora and fauna of the proposed environmental treatment facility and water use reduction project at the Reversing Falls Mill in Saint John, New Brunswick.....	204
Table 56. Assessment of potential impacts on aquatic flora and fauna of the proposed environmental treatment facility and water use reduction project at the Reversing Falls Mill in Saint John, New Brunswick.....	206
Table 57. The type of cause-effect relationships that are possible and the mechanisms by which stressors could ultimately lead to impacts on labour and economy during various stages associated with the proposed environmental treatment facility and water use reduction project at the Reversing Falls Mill in Saint John, New Brunswick.....	207
Table 58. The type of cause-effect relationships that are possible and the mechanisms by which stressors could ultimately lead to impacts on archaeological and cultural resources during various activities associated with the proposed environmental treatment facility and water use reduction project at the Reversing Falls Mill in Saint John, New Brunswick.....	209
Table 59. The type of cause-effect relationships that are possible and the mechanisms by which stressors could ultimately lead to impacts on the transportation network during various activities associated with the proposed environmental treatment facility and water use reduction project at the Reversing Falls Mill in Saint John, New Brunswick.....	212
Table 60. The type of cause-effect relationships that are possible and the mechanisms by which stressors could ultimately lead to impacts on aesthetics during various activities associated with the proposed environmental treatment facility and water use reduction project at the Reversing Falls Mill in Saint John, New Brunswick.....	216
Table 61. The type of cause-effect relationships that are possible and the mechanisms by which stressors could ultimately lead to impacts on recreation and tourism during various activities associated with the proposed environmental treatment facility and water use reduction project at the Reversing Falls Mill in Saint John, New Brunswick.....	223
Table 62. The type of cause-effect relationships that are possible and the mechanisms by which stressors could ultimately lead to impacts on health and safety during various stages associated with the proposed environmental treatment facility and water use reduction project at the Reversing Falls Mill in Saint John, New Brunswick.....	225
Table 63. Assessment of potential impacts on labour and economy of the proposed environmental treatment facility and water use reduction project at the Reversing Falls Mill in Saint John, New Brunswick.....	228

Table 64. Assessment of potential impacts on archaeological and cultural features of the proposed environmental treatment facility and water use reduction project at the Reversing Falls Mill in Saint John, New Brunswick.....	229
Table 65. Assessment of potential impacts on the transportation network of the proposed environmental treatment facility and water use reduction project at the Reversing Falls Mill in Saint John, New Brunswick.....	230
Table 66. Assessment of potential impacts on aesthetics of the proposed environmental treatment facility and water use reduction project at the Reversing Falls Mill in Saint John, New Brunswick.....	231
Table 67. Assessment of potential impacts on recreation and tourism of the proposed environmental treatment facility and water use reduction project at the Reversing Falls Mill in Saint John, New Brunswick.....	232
Table 68. Assessment of potential impacts on health and safety of the proposed environmental treatment facility and water use reduction project at the Reversing Falls Mill in Saint John, New Brunswick.....	233
Table 69. Summary of the potential impacts of the proposed environmental treatment facility and water use reduction project at the Reversing Falls Mill in Saint John, New Brunswick on selected valued environmental components.....	234
Table 70. Potential concerns and mitigation measures of increased temperature under a changing climate on the proposed environmental treatment facility and water use reduction project at the Reversing Falls Mill in Saint John, New Brunswick.	239
Table 71. Potential concerns and mitigation measures of increased precipitation under a changing climate on the proposed environmental treatment facility and water use reduction project at the Reversing Falls Mill in Saint John, New Brunswick.	241
Table 72. Significant earthquakes recorded in New Brunswick between 1600 and 2017 as reported by <i>Lamontagne et al.</i> [2018].	248
Table 73. 2015 National Building Code interpolated ground motions calculated for the Reversing Falls Mill site in Saint John, New Brunswick using Natural Resources Canada’s seismic hazard calculator.....	250
Table 74. Chiefs and Consultation Directors of New Brunswick’s First Nations who will be sent information regarding the environmental treatment facility and water use reduction project proposed for the Reversing Falls Mill in Saint John, New Brunswick.....	258
Table 75. Attendees of the pre-registration consultation videoconference held on 21 September 2021 regarding the proposed environmental treatment facility and water use reduction project at the Reversing Falls Mill in Saint John, New Brunswick.	261
Table 76. Attendees of the pre-registration consultation videoconference held on 6 October 2021 regarding the proposed environmental treatment facility and water use reduction project at the Reversing Falls Mill in Saint John, New Brunswick.	261
Table 77. Attendees of the pre-registration consultation videoconference held on 2 February 2022 regarding the proposed environmental treatment facility and water use reduction project at the Reversing Falls Mill in Saint John, New Brunswick.	262
Table 78. Elected officials, service groups, environmental groups, and stakeholders who will be sent information regarding the environmental treatment facility and water	

use reduction project proposed for the Reversing Falls Mill in Saint John, New Brunswick.....	263
Table 79. Permitted uses based on zoning in the City of Saint John, New Brunswick.	282

FIGURES

Figure 1. Aerial photograph, circa 2021, showing the properties that comprise the Reversing Falls Mill at the mouth of the Saint John River in Saint John, New Brunswick.....	3
Figure 2. The Reversing Falls Mill located near the mouth of the Saint John River in Saint John, New Brunswick.....	4
Figure 3. Overall benefits of the environmental treatment facility and water use reduction project planned for the Reversing Falls Mill in Saint John, New Brunswick.	8
Figure 4. Brief evolution of the Pulp and Paper Effluent Regulations since they were first introduced under the federal <i>Fisheries Act</i> [R.S.C. 1985, c. F-14] in 1971.....	10
Figure 5. Oblique view showing the general location of the environmental treatment facility and the water use reduction infrastructure (<i>i.e.</i> , shown within red boxes) proposed for the Reversing Falls Mill in Saint John, New Brunswick.	13
Figure 6. Aerial view showing the general location of the environmental treatment facility and the water use reduction infrastructure (<i>i.e.</i> , shown in red) proposed for the Reversing Falls Mill in Saint John, New Brunswick.....	14
Figure 7. Locations considered for siting the environmental treatment facility for the Reversing Falls Mill in Saint John, New Brunswick.....	15
Figure 8. Canadian pulp and paper mills active in 2017 (<i>n.b.</i> , active was determined based on mills reporting to the National Pollutant Release Inventory in 2017, the most recent year available) and their respective effluent treatment technology.	18
Figure 9. Simplified flow diagram of an aerated stabilization basin process used for treating effluent.	19
Figure 10. Simplified flow diagram of the activated sludge treatment process used for treating effluent.	20
Figure 11. Simplified flow diagram of a typical moving bed biofilm reactor arrangement used for treating effluent.....	20
Figure 12. Examples of plastic carrier media used within a moving bed biofilm reactor to support bacteria growth.	21
Figure 13. Simplified flow diagram of a nutrient limited biological activated sludge arrangement used for treating effluent.....	21
Figure 14. Simplified flow diagram of a single sequential batch reactor showing the five steps used for treating effluent.	22
Figure 15. Simplified flow diagram of a membrane biological reactor system used for treating effluent.	23

Figure 16. Sites visited by the Project team to experience and observe some of the effluent treatment technologies used at pulp and paper mills.	23
Figure 17. Photograph showing the moving bed biofilm reactor pilot plant that was operated at the Reversing Falls Mill in Saint John, New Brunswick.	27
Figure 18. Photograph showing the nutrient limited biological activated sludge pilot plant that was operated at the Reversing Falls Mill in Saint John, New Brunswick.	27
Figure 19. Simplified flow diagram of the two pilot plants operated at the Reversing Falls Mill in Saint John, New Brunswick.	28
Figure 20. Major components of the environmental treatment facility and water use reduction project proposed for the Reversing Falls Mill in Saint John, New Brunswick.	29
Figure 21. General layout and main components of the environmental treatment facility proposed for the Reversing Falls Mill in Saint John, New Brunswick. The numbers follow the effluent through the treatment process.	30
Figure 22. Simple flow diagram for the environmental treatment facility proposed for the Reversing Falls Mill in Saint John, New Brunswick. Equipment shown with black lines is proposed while that shown in thick grey is existing.	31
Figure 23. Cross-section of a typical primary gravity clarifier.	35
Figure 24. Schematic showing an example of an indirect air cooler system proposed for the environmental treatment facility at the Reversing Falls Mill in Saint John, New Brunswick.	39
Figure 25. Cross-section of a typical dissolved air flotation unit.	43
Figure 26. General location for placement of the landscaped berm in three sections to help mask the view of the environmental treatment facility proposed for the Reversing Falls Mill in Saint John, New Brunswick.	51
Figure 27. Summary of the best-in-class technologies to yield additional environmental benefits for the environmental treatment facility proposed for the Reversing Falls Mill in Saint John, New Brunswick.	52
Figure 28. Conceptual flow diagram proposed for water use reduction at the Reversing Falls Mill in Saint John, New Brunswick. Equipment shown with black lines is proposed while that shown in thick grey is existing. The aerial photograph inset shows the location of the Spruce Lake Watershed to the Mill.	53
Figure 29. Photograph showing an example of a high-capacity, low-velocity intake screen.	54
Figure 30. Proposed water intake and pumphouse for water use reduction at the Reversing Falls Mill in Saint John, New Brunswick.	56
Figure 31. Conceptual model showing the micro-tunnelling process that will be used to install the cool water intake pipe proposed for water use reduction at the Reversing Falls Mill in Saint John, New Brunswick.	57
Figure 32. Three-dimensional model looking southwest showing the location of the pumphouse proposed for water use reduction at the Reversing Falls Mill in Saint John, New Brunswick.	58

Figure 33. Three-dimensional model showing the heat exchangers proposed for water use reduction at the Reversing Falls Mill in Saint John, New Brunswick.	59
Figure 34. Summary of the best-in-class technologies to yield additional environmental benefits proposed for water use reduction at the Reversing Falls Mill in Saint John, New Brunswick.	61
Figure 35. Aerial photograph of the Reversing Falls Mill in Saint John, New Brunswick showing the locations proposed for contractor project trailers, project parking areas, material laydown areas, and construction entrances for construction of the proposed environmental treatment facility and water use reduction project.	65
Figure 36. Estimated labour required to construct the environmental treatment facility proposed for the Reversing Falls Mill in Saint John, New Brunswick.	67
Figure 37. High-level project Gantt chart for the construction of the environmental treatment facility and water use reduction project proposed for the Reversing Falls Mill in Saint John, New Brunswick.	70
Figure 38. Compilation of mean daily temperatures measured at the YSJ meteorological station between 1947 and 2008.	72
Figure 39. Compilation of mean daily precipitation measured at the YSJ meteorological station between 1947 and 2008.	72
Figure 40. Compilation of wind speeds measured for the 30 year period between 1981 and 2010 at the Saint John Station A (<i>i.e.</i> , Saint John airport).	73
Figure 41. Mean annual air quality data as measured at NBDELG monitoring locations in Uptown, east, and west Saint John, New Brunswick between 1974 and 2019.	75
Figure 42. Facilities in the greater Saint John area that are required to annually report emissions to Environment Canada’s National Pollutant Release Inventory tracking database.	77
Figure 43. Global and Canadian annually reported greenhouse gas emissions in Megatonnes (Mt) of carbon dioxide equivalent units (CO _{2eq}).	81
Figure 44. Reported total carbon dioxide equivalents (CO _{2eq}), in kilotonnes, for New Brunswick facilities that reported to the Greenhouse Gas Emissions Reporting Program between 2014 and 2018.	82
Figure 45. Aerial photograph, circa 2021, showing the general topography at the Reversing Falls Mill at the mouth of the Saint John River in Saint John, New Brunswick.	83
Figure 46. Aerial photograph, circa 2021, showing regulated watercourses and wetlands in the vicinity of the Reversing Falls Mill at the mouth of the Saint John River in Saint John, New Brunswick.	85
Figure 47. Minimum, mean, and maximum daily water level measurements as recorded at Environment Canada’s hydrometric station on the Saint John River at Saint John, New Brunswick between 1 January 1966 and 31 December 2019.	86
Figure 48. Bedrock geology in the vicinity of the Reversing Falls Mill at the mouth of the Saint John River in Saint John, New Brunswick. See text for bedrock geology descriptions.	88

Figure 49. Surficial geology in the vicinity of the Reversing Falls Mill at the mouth of the Saint John River in Saint John, New Brunswick. See text for surficial geology descriptions.....	90
Figure 50. Groundwater availability map for Saint John, New Brunswick and the surrounding area.....	91
Figure 51. General location of the groundwater well records that were reviewed within 1 km radius of the Reversing Falls Mill at the mouth of the Saint John River in Saint John, New Brunswick.....	92
Figure 52. Compilation of the nine groundwater well records within 1 km radius of the Reversing Falls Mill at the mouth of the Saint John River in Saint John, New Brunswick.....	93
Figure 53. Portion of the Saint John to Grandy Bay, New Brunswick hydrographic chart 4141. Depths are in metres and Union Pt is the site of the Reversing Falls Mill.	94
Figure 54. Bathymetry of the Saint John River in the vicinity of the Reversing Falls Mill in Saint John, New Brunswick. From Appendix XI.....	95
Figure 55. Map showing the recorded observations of species listed under the fSARA and by the COSEWIC within a 5 km radius of the Reversing Falls Mill in Saint John, New Brunswick. Data obtained from the ACCDC.	98
Figure 56. Photographs of species listed under the fSARA and by the COSEWIC that have been observed within a 5 km radius of the Reversing Falls Mill in Saint John, New Brunswick.....	100
Figure 57. Photographs of three bat species listed under the fSARA and by the COSEWIC as being endangered and are known to have been observed within a 5 km radius of the Reversing Falls Mill in Saint John, New Brunswick.	103
Figure 58. Map showing the recorded observations of species listed under the pSARA within a 5 km radius of the Reversing Falls Mill in Saint John, New Brunswick. Data obtained from the ACCDC.	107
Figure 59. Photographs of species listed under the pSARA that have been observed within a 5 km radius of the Reversing Falls Mill in Saint John, New Brunswick.....	109
Figure 60. Photographs of location-sensitive species included in the ACCDC data report within a 5 km radius of <i>The Crossing</i> proposed for east Saint John, New Brunswick.....	110
Figure 61. Map showing the observed flora species within a 5 km radius of the Reversing Falls Mill in Saint John, New Brunswick. Data obtained from the ACCDC.	117
Figure 62. Map showing the observed birds within a 5 km radius of the Reversing Falls Mill in Saint John, New Brunswick. Data obtained from the ACCDC.	118
Figure 63. Map showing observed mammals, arthropods, and molluscs within a 5 km radius of the Reversing Falls Mill in Saint John, New Brunswick. Data obtained from the ACCDC.	119
Figure 64. Areas of the Lower Saint John River that have been investigated by various researchers and where species observations are available.....	121

Figure 65. Map showing the environmentally significant and managed areas within a 5 km radius of the Reversing Falls Mill in Saint John, New Brunswick. Data obtained from the ACCDC.	124
Figure 66. 2016 Statistics Canada demographics of the Saint John census metropolitan area.	126
Figure 67. New Brunswick monthly unemployment rate between January 2017 and July 2021 based on data from New Brunswick Department of Labour and Statistics Canada.	127
Figure 68. Archaeological predictive modelling in the vicinity of the Reversing Falls Mill Project site in Saint John, New Brunswick. Source: New Brunswick Department of Tourism, Heritage, and Culture.	131
Figure 69. A copy of Samuel de Champlain’s 1604 chart of the Saint John Harbour. From <i>Raymond</i> [1905].	132
Figure 70. New Brunswick’s First Nations communities.	133
Figure 71. Aerial photograph showing the location of Goat Island, Indian Island, and Burnt Island in relation to the Reversing Falls Mill in Saint John, New Brunswick.	134
Figure 72. Aerial photograph, circa 1953, of the Reversing Falls Mill in Saint John, New Brunswick.	137
Figure 73. Aerial photograph, circa 1962, of the Reversing Falls Mill in Saint John, New Brunswick.	138
Figure 74. Aerial photograph, circa 1976, of the Reversing Falls Mill in Saint John, New Brunswick.	139
Figure 75. Aerial photograph, circa 1984, of the Reversing Falls Mill in Saint John, New Brunswick.	140
Figure 76. Aerial photograph, circa 1994, of the Reversing Falls Mill in Saint John, New Brunswick.	141
Figure 77. Aerial photograph, circa 2011, of the Reversing Falls Mill in Saint John, New Brunswick.	142
Figure 78. Map showing truck, railway, and port connections to the Reversing Falls Mill in Saint John, New Brunswick.	145
Figure 79. Aerial photograph showing the major municipal waterlines and sewer lines in the vicinity of the Reversing Falls Mill in Saint John, New Brunswick.	147
Figure 80. Panoramic photographs showing the skyline of east Saint John, Uptown Saint John, and west Saint John, New Brunswick.	148
Figure 81. Several tourist attractions in the vicinity of the Reversing Falls Mill in Saint John, New Brunswick.	149
Figure 82. The New Brunswick Department of the Environment and Local Government’s Environmental Impact Assessment (EIA) step-wise determination review process highlighting the public consultation component of the process (<i>i.e.</i> , the blue box). Source <i>NBDELG</i> [2018].	152
Figure 83. Preference hierarchy associated with impacts under environmental assessment review.	154

Figure 84. Visual representation of the process used in assessing the Project's impact on the environment.....	158
Figure 85. Location of the total reduced sulphur air quality monitoring station at the Reversing Falls Mill in Saint John, New Brunswick in relation to the proposed environmental treatment facility.	166
Figure 86. Typical sound levels from construction equipment experienced by a receptor at 15 m distant. After <i>USEPA</i> [1971].....	169
Figure 87. Google Earth photograph showing the general location of the Main Mill Outfall at the Reversing Falls Mill in Saint John, New Brunswick.	177
Figure 88. Oblique Google Earth photograph showing the location of the Main Mill Outfall at the Reversing Falls Mill in Saint John, New Brunswick. Also shown are drone photographs showing the Main Mill Outfall.	177
Figure 89. Water velocity profiles in the vicinity of the Reversing Falls Mill in Saint John, New Brunswick during an ebb tide and flood tide produced using the three-dimensional hydrodynamic model TELEMAC-3D.	178
Figure 90. Steady-state surface effluent plume dilution snapshots following discharge from the Main Mill Outfall of the Reversing Falls Mill in Saint John, New Brunswick modelled under existing conditions and after the environmental treatment facility and water use reduction project is in operation.....	180
Figure 91. Steady-state near-bed effluent plume dilution snapshots following discharge from the Main Mill Outfall of the Reversing Falls Mill in Saint John, New Brunswick modelled under existing conditions and after the environmental treatment facility and water use reduction project is in operation.....	181
Figure 92. City of Saint John, New Brunswick zoning map in the vicinity of Reversing Falls Mill.	215
Figure 93. Conceptual image looking southeast towards the environmental treatment facility proposed for the Reversing Falls Mill in Saint John, New Brunswick. Note: the three sections of the berm are optional.	217
Figure 94. Conceptual image looking east towards the environmental treatment facility proposed for the Reversing Falls Mill in Saint John, New Brunswick. Note: the three sections of the berm are optional.....	217
Figure 95. Conceptual image looking west towards the environmental treatment facility proposed for the Reversing Falls Mill in Saint John, New Brunswick. Note: the three sections of the berm are optional.....	218
Figure 96. Google Earth Street View image circa June 2019 taken between 397 and 423 Milford Road looking east towards the Reversing Falls Mill in Saint John, New Brunswick. Modelled images show the same view with the proposed environmental treatment facility in the background at year 1 and year 5 showing tree growth of the landscaped berm along Milford Road.	219
Figure 97. Google Earth Street View image circa June 2019 taken near 386 Milford Road looking southeast towards the Reversing Falls Mill in Saint John, New Brunswick. Modelled images show the same view with the proposed environmental treatment facility in the background at year 1 and year 5 showing tree growth of the landscaped berm along Milford Road.	220

Figure 98. Portion of the 1875 map of Lancaster, New Brunswick showing the location of the proposed environmental treatment facility at the present day Reversing Falls Mill site [Roe and Colby, 1875].....	221
Figure 99. Global natural loss extreme weather related events between 1980 and 2019 with at least one fatality and / or produced normalized losses over the threshold assigned by the World Bank [NatCatSERVICE, 2019].....	238
Figure 100. Characterization of the 83 natural disasters for New Brunswick between 1900 and 2019 as recorded in the Canadian Disaster Database [PSC, 2019].	238
Figure 101. Number of named storms experienced annually within the Atlantic region between 1850 and 2020.....	244
Figure 102. Historical sulphur oxide and nitrous oxide emissions for New Brunswick as reported by the ECCC [2021d].	246
Figure 103. Map showing the Northern Appalachian Seismic Zone (NAP) from Geological Survey of Canada [2021].	247
Figure 104. Spectral acceleration for a period of 0.2 s at a probability of 2 % · 50 yr ⁻¹ for firm ground conditions (i.e., NBCC soil class C) from Natural Resources Canada [2021].	249
Figure 105. Schematics showing the generalized process of post-glacial rebound and map showing uplift and subsidence of land masses across Canada due to post-glacial rebound [Environment Canada, 2006]. Dots on the map represent Canadian Base Network (CBN) sites.	251
Figure 106. Land in vicinity of the Reversing Falls Mill in Saint John, New Brunswick that are projected to be below the 2030 annual flood level (i.e., areas shaded blue).	252
Figure 107. Land in vicinity of the Reversing Falls Mill in Saint John, New Brunswick that are projected to be below the 2050 annual flood level (i.e., areas shaded red).....	253
Figure 108. Land in vicinity of the Reversing Falls Mill in Saint John, New Brunswick that are projected to be below the 2100 annual flood level (i.e., areas shaded red).....	253
Figure 109. Residential properties in the vicinity of the proposed Project at the Reversing Falls Mill in Saint John, New Brunswick that will receive notification of the Project.	266
Figure 110. Example of the public notice announcement that will be placed by the Proponent in at least one local newspaper and / or at least one provincial daily newspaper.....	268
Figure 111. Permitting roadmap for the environmental treatment facility and water use reduction project proposed for the Reversing Falls Mill in Saint John, New Brunswick.....	271

ACRONYMS

ADMT:	Air Dry Metric Tonnes
ACAPSJ:	Atlantic Coastal Action Program Saint John Chapter
ACCDC:	Atlantic Canada Conservation Data Centre

a.k.a.:	also known as
AM:	(<i>ante meridiem</i>) before midday
AMSL:	Above Mean Sea Level
ANB:	Ambulance New Brunswick
AOX:	Adsorbable Organic halides
ASB:	Aerated Stabilization Basin
ASHRAE:	American Society of Heating, Refrigeration, and Air-Conditioning Engineers
AST:	Activated Sludge Treatment
ATC:	Approval To Construct
ATO:	Approval To Operate
BAB:	Big Air Bubble
BAB:	Best-Available Technology
BMPs:	Best-Management Practices
BOD:	Biochemical Oxygen Demand
BOD ₅ :	five day Biochemical Oxygen Demand
%:	Care Of
<i>c.f.</i> :	(<i>confer</i>) compare or consult
CDD:	Canadian Disaster Database
CFU:	ColiForm Unit
CH:	Caledonia Highlands
CH ₄ N ₂ O:	urea
CMA:	Census Metropolitan Area
CN:	Canadian National
Co.:	Corporation
CO:	Carbon monoxide
CO ₂ :	Carbon dioxide
CO _{2eq} :	Carbon dioxide equivalents
COD:	Chemical Oxygen Demand
COMEX:	COMmunity EXpress
CONSEP:	CONtractor Safety and Environmental Program
COSEWIC:	Committee On Status of Endangered Wildlife in Canada
cm:	centimeter
CRI:	Canadian Rivers Institute

CWS:	Canadian Wildlife Service
DAF:	Dissolved Air Flotation
dBA:	A-weighted deciBels (<i>i.e.</i> , relative loudness)
DDT:	Dichloro-Diphenyl-Trichloroethane
DFO:	Department of Fisheries and Oceans
<i>e.g.</i> :	(<i>exempli gratia</i>) for example
ECCC:	Environment and Climate Change Canada
EEM:	Environmental Effects Monitoring
EIA:	Environmental Impact Assessment
EMO:	Emergency Management Organization
EMP:	Emergency Management Plan
EMS:	Environmental Management System
EP:	Environmental Professional
EPP:	Environmental Protection Plan
EQ:	EQualization tank
ERP&ECP:	Emergency Response Plan & Environmental Contingency Plan
ESA:	Environmentally Significant Area
<i>et al.</i> :	(<i>et alii</i>) and others
<i>etc.</i> :	(<i>et cetera</i>) and so forth
ETF:	Environmental Treatment Facility
EY:	Ernst and Young
FGC:	Fellow of Geoscience Canada
fSARA:	federal <i>Species At Risk Act</i>
GDP:	Gross Domestic Product
GHG:	GreenHouse Gases
GHGRP:	GreenHouse Gas Reporting Program
GIS:	Geographical Information System
GP:	General Partnership
ha:	hectare
HDPE:	High-Density PolyEthylene
H ₂ S:	Hydrogen Sulphide
H ₃ PO ₄ :	phosphoric acid
hr:	hour

<i>i.e.:</i>	<i>(id est)</i> namely / that is
IAAC:	Impact Assessment Agency of Canada
IBA:	Important Bird Area
ID:	IDentification
IH:	Heavy Industrial
IPCC:	International Panel on Climate Change
IPP:	Irving Pulp and Paper
ISO:	International Standards Organization
JDI:	J.D. Irving, Limited
JOHSC:	Joint Occupational Health and Safety Committee
kg:	kilogram
km:	kilometer
km ² :	kilometers squared
kPa:	kiloPascal
kt:	kilotonne
kW:	kiloWatt
L:	Litre
L.P.:	Limited Partnership
LED:	Light-Emitting Diode
Ltd.:	Limited
m:	meters
m ² :	square meters
m ³ :	cubic meters
MBBR:	Moving Bed Biofilm Reactor
MBR:	Membrane Biological Reactor
mg:	milligram
min:	minute
mm:	millimeter
MMO:	Main Mill Outfall
MO:	MOncton
Mt:	Megatonnes
MTI:	Mi'gmawe'l Tplu'taqnn Inc.
MW:	MegaWatt

mya:	million years ago
<i>n</i> :	statistical value that refers to the number of observations
N:	North; Nitrogen
<i>n.b.</i> :	(<i>nota bene</i>) note well / take note
NaOCl:	sodium hypochlorite
NaOH:	sodium hydroxide
NAP:	Northern APpalachian
NAPS:	National Air Pollution Surveillance
NAVWARN:	NAVigation WARNing
NB:	New Brunswick
NBCC:	National Building Code of Canada
NBDAA:	New Brunswick Department of Aboriginal Affairs
NBDELG:	New Brunswick Department of Environment and Local Government
NBDJPS:	New Brunswick Department of Justice and Public Safety
NBDNRED:	New Brunswick Department of Natural Resources and Energy Development
NBDPSETL:	New Brunswick Department of Post-Secondary Education, Training, and Labour
NBDTI:	New Brunswick Department of Transportation and Infrastructure
NBFPI:	New Brunswick Forest Products Industry
NBSR:	New Brunswick Southern Railway
NFPA:	National Fire Protection Association
NGO:	Non-Governmental Organization
NH ₃ :	ammonium
NH ₄ :	ammonia
NLBAS:	Nutrient Limited Biological Activated Sludge
Nm ³ :	Normal cubic metre
NO ₂ :	Nitrogen Oxides
NPRI:	National Pollutant Release Inventory
NRC:	National Research Council
NS:	Nova Scotia
O ₃ :	Ozone
<i>OHSA</i> :	<i>Occupational Health and Safety Act</i>
P:	Phosphorous
<i>P.Eng.</i> :	Professional Engineer

<i>P.Geo.:</i>	Professional Geoscientist
PB:	Passamaquoddy Bay
PDF:	Portable Document Format
PID:	Property IDentifier
PM:	Particulate Matter or (<i>post meridiem</i>) after midday
PM _{2.5} :	Particulate Matter less than 2.5 microns
PM ₁₀ :	Particulate Matter less than 10 microns
PNB:	Province of New Brunswick
PO:	Post Office
ppb:	parts per billion
PPE:	Personal Protective Equipment
PPERs:	Pulp and Paper Effluent Regulations
ppm:	parts per million
pSARA:	provincial <i>Species At Risk Act</i>
PSC:	Public Safety Commission
PSJ:	Port Saint John
PVC:	PolyVinyl Chloride
RPM:	Revolutions Per Minute
s:	seconds
SARA:	<i>Species At Risk Act</i>
SBR:	Sequential Batch Reactor
SRES:	Special Report on Emission Scenarios
SJFD:	Saint John Fire Department
SJPF:	Saint John Police Force
SJTC:	Saint John Transit Commission
SJW:	Saint John Water
<i>sp.:</i>	specific species name cannot be specified
StatsCan:	Statistics Canada
SO ₂ :	Sulfur Dioxide
t:	tonnes
™:	Trade Mark
TOC:	Total Organic Carbon
TRC:	Technical Review Committee

TRS:	Total Reduced Sulphur
TSS:	Total Suspended Solids
US:	United States
USEPA:	United States Environmental Protection Agency
VEC:	Valued Environmental Component
VOCs:	Volatile Organic Compounds
yr:	year
YSJ:	Saint John Airport
W:	West
w / w:	weight to weight
WAWA:	Watercourse And Wetland Alteration
WMO:	World Meteorological Organization
WSLS:	West Side Lift Station
WUR:	Water Use Reduction
WWNB:	Wolastoqey Nation in New Brunswick
°:	degrees
°C:	degrees Celsius
%:	percent
µg:	micrograms
>:	greater than
≥:	greater than or equal to
<:	less than
≤:	less than or equal to
~:	approximately
±:	plus or minus
\$:	dollars

1.0 PROPONENT

1.1 PROPONENT NAME

The proponent for this Project is Irving Pulp & Paper (IPP), Limited, which is a division of J.D. Irving, Limited (JDI).

1.2 PROPONENT ADDRESS

PO Box 3007
408 Mill Street
Saint John, New Brunswick
E2M 3H1

1.3 PROPONENT CONTACT

Ms. Renée Morais, *P.Eng.*
Director of Environment
J.D. Irving Limited
PO Box 5777
300 Union Street
Saint John, NB
E2L 4M3

📞 506.647.0418
📠 506.634.4245
🌐 www.jdirving.com
✉ morais.renee@jdirving.com

1.4 PRINCIPAL CONTACT FOR PURPOSES OF ENVIRONMENTAL IMPACT ASSESSMENT

Fundy Engineering & Consulting Ltd. (Fundy Engineering) prepared this Environmental Impact Assessment (EIA) Registration Document. The principal contact at Fundy Engineering with respect to this EIA is:

Dr. Matt Alexander, *P.Geo., FGC, EP*
Fundy Engineering & Consulting Ltd.
27 Wellington Row
Saint John, New Brunswick
E2L 3H4

📞 506.635.1566
📠 506.635.0206
🌐 www.fundyeng.com
✉ matt.alexander@fundyeng.com

1.5 PROPERTY OWNERSHIP

The proposed Project will occur at the Reversing Falls Mill site at the mouth of the Saint John River in Saint John, New Brunswick. Several land parcels comprise the 71.1 ha Reversing Falls Mill site and they are shown in Figure 1. The properties are all owned by the Proponent and its affiliates. A summary of the properties and their sizes is provided in Table 1 and detailed New Brunswick Geomatics Information Centre database Property Identification (PID) reports are included in Appendix I.

Table 1. List of properties in Saint John, New Brunswick that comprise the Reversing Falls Mill site.

PID	Owner	Lessee(s)	Size (ha)	Description
55162416	Irving Pulp & Paper, Limited	Air Liquide Canada Inc.	48.7	Pulp mill and land
55223739	Irving Pulp & Paper, Limited		18	Water lot parcel A
55232649	Irving Pulp & Paper, Limited		0.2	Pulp mill and land
55232656	Irving Consumer Products Limited		1.7	Tissue mill
55233001	Irving Pulp & Paper, Limited		2.5	Water lot parcel B
TOTAL			71.1	



Figure 1. Aerial photograph, circa 2021, showing the properties that comprise the Reversing Falls Mill at the mouth of the Saint John River in Saint John, New Brunswick.

2.0 PROJECT DESCRIPTION

2.1 PROJECT NAME

For the purposes of this EIA, the Project is referred to as:

ENVIRONMENTAL TREATMENT FACILITY
AND
WATER USE REDUCTION

2.2 PROJECT OVERVIEW

Pulp and Paper Mills have existed at Reversing Falls near the mouth of the Saint John River (Wolastoq) in Saint John, New Brunswick since 1836 [Fundy Engineering, 2014]. IPP has operated a bleached Kraft pulp mill at Reversing Falls (*i.e.*, the Mill) near the mouth of the Saint John River (Figure 2) since the late 1940s when it was purchased from the Port Royal Pulp & Paper Co. Ltd. The Irving Tissue Company has operated a tissue paper mill at Reversing Falls since the late 1980s. The mills are collectively referred to as the Reversing Falls Mill or the Mill throughout this document. A detailed facility profile is provided in *NBDELG* [2021], which is also included in Appendix II.



Figure 2. The Reversing Falls Mill located near the mouth of the Saint John River in Saint John, New Brunswick.

The Mill has undergone numerous upgrades to become the world class pulp producing and tissue producing facility that it is today. Those upgrades (*n.b.*, ~\$600 million has been invested in Mill upgrades since 2005) include:

- new Kraft mill – 1972;
- environmental improvement project – 1996, which included:
 - new fibrelines:
 - oxygen delignification; and
 - wash presses; and
 - modernized evaporators:
 - reverse osmosis; and
 - condensate stripping;
- moving bed biofilm reactor – 1999;
- lime kiln and odour abatement – 2005 to 2006;
- pulp digester and chip handling – 2014 to 2016; and
- pulp dryer – 2019 to 2022

The Mill produces approximately 1 000 Air Dry Metric Tonnes (ADMT) of softwood and hardwood bleached Kraft pulp each day using a variety of physical and chemical processes and approximately 200 machine dry tonnes per day of tissue. With a staff of about 480, the Mill is the anchor of the New Brunswick Forest Products Industry.

2.2.1 Environmental Treatment Facility

Currently, the Reversing Falls Mill operates under a pollution prevention strategy whereby the Mill meets government effluent regulations by recovering, reducing, and reusing pulp-making materials instead of treating waste after it has exited the Mill (*i.e.*, refer to Appendix III). IPP's pollution prevention strategy, which is unique in Canada, has set it apart from other pulp mills around the world. The objectives of the pollution prevention strategy employed at the Mill are to remove, reuse, and recycle chemicals and other pulp-making materials by using modern technology to improve efficiency, cost-competitiveness, and environmental performance while addressing community concerns by avoiding a conventional secondary treatment lagoon and producing optimal effluent quality.

Many best-available technologies have been installed at the Mill as part of the pollution prevention strategy. Those technologies, which led to a significant improvement in Mill effluent quality, included:

- press washing of the unbleached brown stock pulp to recover more used chemicals and organics;
- closing the brown stock screening system to recover dirty process wash water that contains used chemicals and useable wood components;
- adding two stages of oxygen delignification to delignify the pulp for bleaching, maximize the recovery of chemicals and organics, and realize substantial effluent quality improvements;
- installing a highly-efficient condensate stripping column to redirect wood alcohol from incineration and to recover cleaned water;
- adding a highly-efficient reverse osmosis condensate treatment process to treat condensate streams from the evaporation process for reuse and to substantially improve effluent quality;

- establishing spill management systems in the digester, brown stock, bleach plant, pulp drying, recovery, and re-causticizing unit operations;
- enhancing warm and hot water management to reduce water and energy use;
- converting the bleaching process to elemental chlorine-free bleaching to manage dioxins, furans, and Adsorbable Organic halides (AOX); and
- installing a moving bed biofilm reactor to treat bleaching effluent.

Oxygen delignification was implemented at the Mill in 1996 to reduce the amount of chemicals needed in the pulp bleaching process. Those chemicals are incorporated into the recovery process.

The Reversing Falls Mill was the first pulp mill in the world to install a reverse osmosis system. It has led to benefits for aquatic ecosystems and fish health because it removes compounds from the effluent that are responsible for endocrine disruption in fish.

The Moving Bed Biofilm Reactor (MBBR), which comprises 3.5 million plastic carriers housing bacteria, is used to remove wood alcohol from the Mill's process water. The Reversing Falls Mill was the first Kraft mill to use this type of biological system. Implementing this system brought the Mill into environmental compliance with all federal regulations.

IPP is revisiting the option of treating pulp and paper effluent at the Reversing Falls Mill because of regulatory limits anticipated to be imposed on various pulp and paper effluent parameters. Through this Project, IPP will construct and operate an onsite MBBR Environmental Treatment Facility (ETF). An MBBR is being considered because it will be able to meet anticipated future federal pulp and paper effluent discharge limits including Total Suspended Solids (TSS) and Biochemical Oxygen Demand (BOD) and potential discharge limits related to toxicity, pH, Nitrogen (N), Phosphorous (P), temperature, and Chemical Oxygen Demand (COD). Through the current pollution prevention strategy, IPP has experience at the Mill operating an MBBR.

To remain current and maintain efficient and environmentally-sound processes, the Mill routinely undergoes modernization. As part of an on-going, long-term, multi-phase upgrade program to maintain the Mill's global competitiveness, IPP is proposing to install new best-available technology to build upon the existing pollution prevention strategy equipment at the Mill.

2.2.2 Water Use Reduction

The water use reduction component of the Project is critical to building and operating the ETF onsite. Currently, the Mill's average daily effluent flow is $105\,000\text{ m}^3 \cdot \text{day}^{-1}$. Through this Project, the total effluent released will be reduced by about 50 %. Ultimately, the Project will place IPP among the Canadian leaders in the manufacture of pulp and paper by reducing water consumption by up to 50 %. Water use reduction at the Mill will also optimize the ETF size and the ability to fit the facility onsite.

Saint John Water (SJW) obtains water from surface water and groundwater sources. The Spruce Lake Watershed system in west Saint John includes Ludgate Lake, Menzies Lake, the East and West Musquash Reservoirs, Loch Alva, and other lakes that have a combined storage volume of about $16 \times 10^6\text{ m}^3$. Water from the Spruce Lake Watershed

has been used by SJW as a source of raw industrial water and potable water. Residences in west Saint John were supplied with treated water from the Spruce Lake Watershed up until September 2017 when they were switched to the South Bay Wellfield. The Watershed is now only used as a source of raw industrial water.

The Mill has been sourcing its raw industrial freshwater from the Spruce Lake Watershed since 1956. That raw industrial freshwater, which is used for various activities in the pulping process and for cooling portions of the process, is conveyed to the Mill via a 1 372 mm underground pipeline at a rate of about $136\,800\text{ m}^3 \cdot \text{day}^{-1}$. The Mill's cooling water system is a once-through non-contact process (*i.e.*, it does not come into direct contact with any raw material, intermediate or finished product). A significant portion of the water drawn from the Spruce Lake Watershed is warmed within the Mill and subsequently discharged directly to the Saint John River without undergoing any alterations other than a change in temperature. Through the water use reduction project, the majority of non-contact cooling water sourced from the Spruce Lake Watershed will be collected, cooled, and then used in the pulping process. Doing so will reduce the overall quantity of raw industrial freshwater sourced from the Spruce Lake Watershed and simultaneously reduce the Mill's total effluent volume.

Through this Project, a new brackish water heat exchanger system will be used to cool the warmed freshwater sourced from Spruce Lake so that it can be used as process water in the Mill. To do this, cool brackish water will be drawn into the system from the Saint John River through low-velocity inlet screens. The cool brackish water will then be pumped through heat exchangers to extract heat from the warmed Spruce Lake freshwater. After going once-through the heat exchanger, the warmed brackish water will be discharged back to the Saint John River and the cool Spruce Lake freshwater will be sent to the Mill's process water system. This new cooling water system will also be non-contact and the only change to the brackish water returned to the Saint John River will be an increase in temperature. Note that since this Project also reduces the overall effluent discharge temperature, the net heat the River from the site will remain unchanged.

This component of the Project will considerably reduce the volume of raw industrial freshwater drawn from the Spruce Lake Watershed. It is important to note that the amount of heat generated within the Mill by various processes that requires cooling will not change.

2.2.3 Project Benefits

IPP's engineering team spent considerable time and effort developing a Project that will yield substantial benefits as summarized in Figure 2. This was done by reviewing many technologies, selecting the leader, and then developing best-management operating practices. As a result, in concert with the existing pollution prevention equipment, this Project will place IPP among the global leaders in process water use and effluent treatment performance.

OVERALL PROJECT BENEFITS



Figure 3. Overall benefits of the environmental treatment facility and water use reduction project planned for the Reversing Falls Mill in Saint John, New Brunswick.

2.3 PURPOSE OF THIS ENVIRONMENTAL IMPACT ASSESSMENT

The purpose of an EIA is to identify and evaluate the potential impacts that the proposed Project may have on the environment. As per Schedule A, item k) (*i.e.*, all facilities for the commercial processing or treatment of timber resources...) and item n) (*i.e.*, all sewage¹ disposal or sewage treatment facilities, other than domestic, onsite facilities...) of the Environmental Impact Assessment Regulation [87-83] of the New Brunswick *Clean Environment Act* [R.S.N.B. 1973, c. C-6], the Project triggers EIA review. This EIA was prepared by Fundy Engineering & Consulting Ltd. (Fundy Engineering) on behalf of IPP (% Ms. Renée Morais). The EIA identifies potential environmental impacts this Project may pose and presents measures to mitigate those potential environmental impacts. This EIA meets the requirements of the *NBDELG* [2018] guide to EIAs and the *NBDELG* [2004] Sector Guidelines for Wastewater Treatment Projects.

2.4 PROJECT PURPOSE / RATIONALE / NEED

In Canada, the Pulp and Paper Effluent Regulations (PPERs) [SOR / 92-269] of the federal *Fisheries Act* [R.S.C., 1985, c.F-14] govern the discharge of harmful substances from pulp and paper mills into waters frequented by fish². The first version of the PPERs were issued in 1971 (Figure 4) and introduced:

- limits for TSS;
- limits for BOD; and
- a prohibition on the discharge of effluents that displayed an acute lethality to rainbow trout (*Oncorhynchus mykiss*) based on a standard bioassay.

The TSS and BOD limits in the 1971 PPERs, which were mass-based, came about to encourage mill operators to modify their processes. The overarching goal was to improve water quality and protect fish, fish habitat, and the use of fisheries resources. The 1971 PPERs were only applicable to new, expanded, and / or altered mills. The regulations were non-enforceable for existing mills because it was assumed that new mills could cost-

¹ The definition for sewage was repealed in 1993 and replaced with wastewater, which includes all industrial wastewater or domestic wastewater, whether treated or untreated, containing human, animal, vegetable, or mineral matter in liquid or solid form, in suspension or in solution.

² No specific approvals or permits are required

effectively incorporate modern pollution prevention-based production technologies and effluent treatment systems into their design. It was also believed that existing mills would be penalized by facing excessive costs to install new effluent treatment systems.

After several years of research and extensive stakeholder and public consultations, the 1971 PPERs were amended in 1992 to further enhance effluent quality discharged from pulp and paper mills. The amended regulations introduced:

- enforceable effluent quality standards for all mills and offsite treatment facilities based on standards achievable using secondary wastewater treatment;
- a requirement for all mills and offsite treatment facilities to produce effluents that are not acutely lethal to rainbow trout; and
- a requirement for all mills and offsite treatment facilities to comply with comprehensive Environmental Effects Monitoring (EEM) requirements.

The 1992 PPERs applied to all pulp and paper mills (*i.e.*, new and existing mills); however, existing mills were given a four year transition period to comply with the amendments. On 1 January 1996, all mills in Canada became subject to the 1992 PPERs.

To streamline and improve clarity of the 1992 PPERs so compliance and enforcement could be more practical, some improvements were made in 2004. Although the fundamental requirements of the 1992 PPERs did not change, adjustments were made to the monitoring and reporting requirements under the EEM program. More specifically, the 2004 changes included:

- less prescriptive requirements for conducting EEM studies;
- a requirement that EEM studies be performed and reported in accordance with generally accepted standards of good scientific practice; and
- additional EEM requirements for mills to investigate the cause(s) of environmental effects associated with their effluents.

Some additional changes were made to the 1992 PPERs in 2008 to improve the effectiveness and efficiency of the EEM requirements. Those changes included:

- an additional EEM requirement for mills to investigate solutions to eliminate environmental effects associated with their effluents;
- suspension of EEM at mills that have ceased production for at least eight consecutive months; and
- streamlining of requirements for sublethal toxicity testing, biological monitoring studies, and assessments of the magnitude and extent of observed effects.

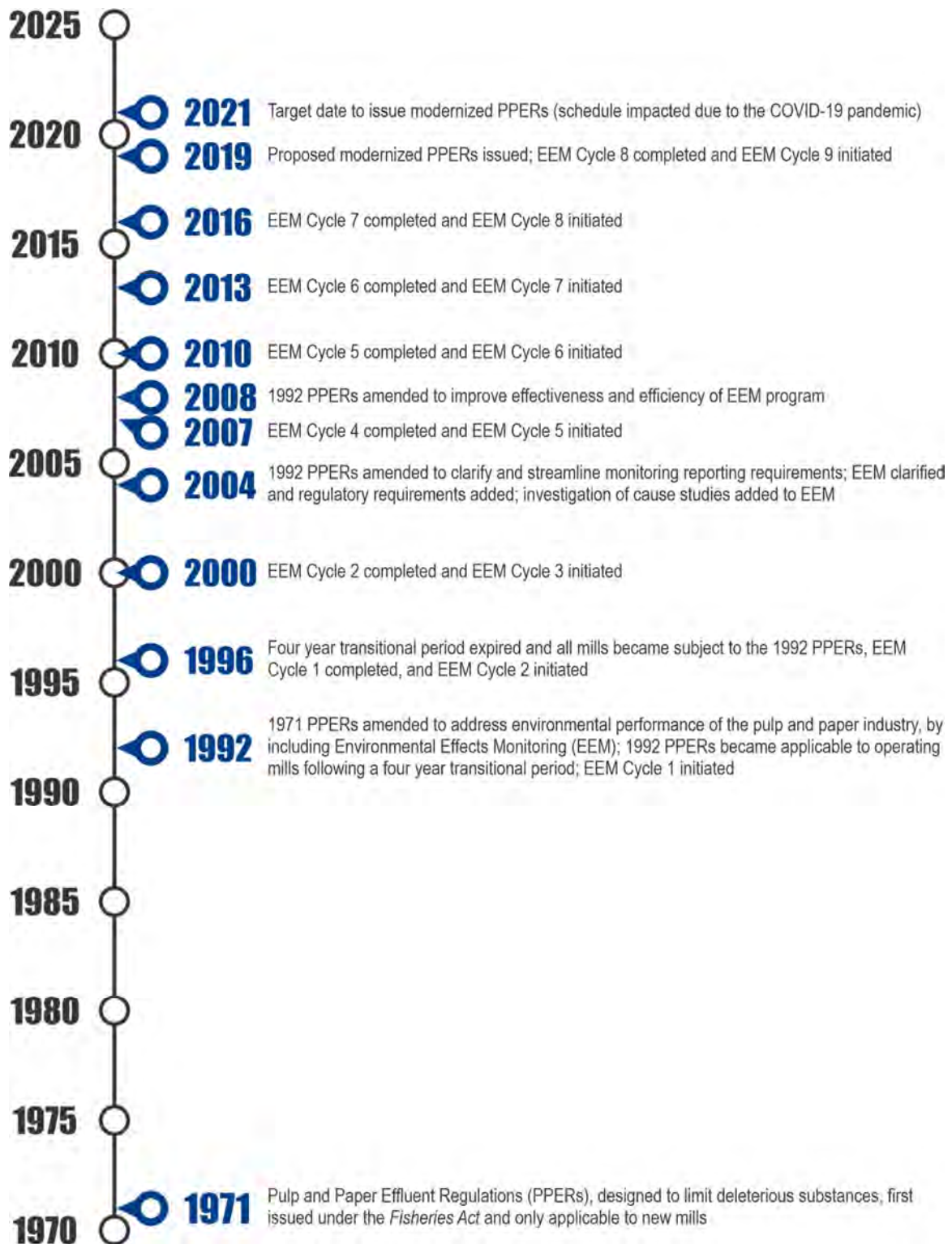

Figure 4. Brief evolution of the Pulp and Paper Effluent Regulations since they were first introduced under the federal *Fisheries Act* [R.S.C. 1985, c. F-14] in 1971.

Briefly, the 1992 PPERs, which were amended in 2004 and 2008, require mills to:

- monitor effluent;
- install, maintain, and calibrate monitoring equipment and retain records of that equipment;
- submit monthly reports containing effluent monitoring results and daily production information;
- notify an inspector of a test result that indicates a failure or non-compliance;
- submit identifying information;
- annually prepare and update a remedial plan that describes the measures to be taken by the operator to eliminate all unauthorized deposits of deleterious substances in the case where effluent fails an acute lethality test;
- prepare an emergency response plan and make it readily available on site;
- provide information related to the reference production rate;
- submit information on outfall structures;
- only deposit effluent through identified outfall structures;
- comply with requirements for EEM studies;
- keep records available for inspection;
- request an authorization to combine effluents;
- provide written reports and additional sampling for the deposit of a deleterious substance in water frequented by fish that is not authorized under the *Fisheries Act* [R.S.C. 1985, c. F-14] which results or may result in detriment to fish, fish habitat, or the use of fish by humans.

Environment and Climate Change Canada (ECCC) is modernizing the PPERs to further improve environmental protection and enable the biotransformation of the pulp and paper industry. Four key areas are being proposed for modernization [ECCC, 2017]:

- 1) environmental protection measures;
- 2) scope of the regulations;
- 3) administrative improvements; and
- 4) compliance and administrative requirements.

The current PPERs establish limits on effluent quality parameters including TSS and BOD. The purpose of the PPERs is to manage threats posed to fish, fish habitat, and human health from fish consumption by pulp and paper effluents. The Reversing Falls Mill, like every other Canadian pulp and paper mill, has been subject to the PPERs since at least 1996. The proposed PPER effluent limits compared to the current limits is summarized in Table 2.

Table 2. Current and proposed pulp and paper effluent regulation limits under the federal *Fisheries Act* [R.S.C. 1985, c. F-14] [ECCC, 2019].

Parameter	Frequency / Location	Current Limit for All Mills	Proposed Limit for Chemical Mills*
BOD (kg · t ⁻¹)	Daily	12.5	4.25
	Monthly	7.5	2.6
TSS (kg · t ⁻¹)	Daily	18.75	6.25
	Monthly	11.25	3.75
COD (kg · t ⁻¹)	Daily	None	75
	Monthly	None	45
Maximum Average P _{TOTAL} (mg · L ⁻¹)	Weekly	None	2.0
	Monthly	None	1.5
Maximum Average N _{TOTAL} (mg · L ⁻¹)	Weekly	None	20
	Monthly	None	15
Final Max. Effluent Temperature (°C)	Daily	None	40
	Monthly	None	35
Final Effluent pH Range	Freshwater	None	6.0 to 9.5
	Marine / Estuary	None	6.5 to 9.2

NOTES:

*Mills that are designed to operate a recovery boiler, a lime kiln, or a pulping digester

Originally, the target date for implementing the new PPERs was December 2021 (Figure 4); however, the COVID-19 pandemic has impacted the schedule. It has been “penned down” on the file since the start of the pandemic and it is not currently known when work will reoccur or when the new PPERs will be realized (*n.b.*, the modernization is on hold until at least late 2022). Therefore, it is understood that PPER modernization is still under consideration.

The New Brunswick Forest Products Industry (NBFPI) is an integral component of the Province’s natural resource-based economy. More than 6 million hectares of forested lands are managed throughout the Province. In 2016, forestry accounted for 5.7 % of the Province’s Gross Domestic Product [*Forest NB*, 2016]. Throughout the Province the NBFPI is a direct employer to about 9 725, who in 2016 earned about \$529 million in wages and salaries.

Saint John is the hub of the NBFPI; about one out of every 25 people in Saint John is employed by the forest-related industry. One of the largest NBFPI employers in Saint John is the Mill, which has a labour force of approximately 480. Those employees provide a crucial link in the use of the Province’s wood resource by processing sawmill by-products (*i.e.*, wood chips). Annually, the Mill purchases about \$70 million in goods and services from NB suppliers and the employees contribute to the Saint John community and economy.

The global market for supplying Kraft pulp to paper and allied product manufacturers is extremely aggressive. For IPP to remain successful in that competitive market, it is essential that they continuously upgrade major equipment with more efficient and higher quality producing technologies. This Project is a critical upgrade that is fundamental to the long-term environmental viability of the Mill. This Project will maintain a livelihood for many New Brunswickers by ensuring that the Mill, which is an anchor of New Brunswick’s

forest products industry, remains efficient to ensure effective productivity, product quality, and profitability in environmentally sustainable manner.

Safeguarding the environment has been and continues to be IPP's top priority. As the result of a directive issued in 2018 by ECCC, IPP has committed to building and operating an ETF. Representatives from IPP and ECCC have met bi-annually since September 2018 to discuss progress on design of the ETF. When complete, the Project will improve characteristics of the Mill's treated effluent being discharged to the Saint John River.

2.5 PROJECT LOCATION

Operationally, it is necessary to site the Project in close proximity to existing processes. Large quantities of water will have to be pumped to and from the ETF and heat exchangers. Therefore, reducing the distance travelled is optimal. Through considerable engineering effort, the Project will be constructed on the west side and east side of the Mill site. The permanent Project infrastructure will be constructed and operated entirely within the boundaries of Mill (Figure 5 and Figure 6). Approximate central coordinates for the ETF are 45°15'50.01"N and 66°06'05.14"W while those for the water use reduction are 45°15'37.61"N and 66°05'25.96"W.



Figure 5. Oblique view showing the general location of the environmental treatment facility and the water use reduction infrastructure (*i.e.*, shown within red boxes) proposed for the Reversing Falls Mill in Saint John, New Brunswick.



Figure 6. Aerial view showing the general location of the environmental treatment facility and the water use reduction infrastructure (*i.e.*, shown in red) proposed for the Reversing Falls Mill in Saint John, New Brunswick.

2.6 PROJECT ALTERNATIVES

Several Project alternatives, primarily with respect to the ETF location and treatment technology, were considered as described below.

2.6.1 Null Alternative

The null alternative (*i.e.*, the do-nothing approach) was considered in order to compare other alternatives for the various Project components (*n.b.*, the baseline environment represents the null alternative). Under this alternative, the Project would not be undertaken. **Not completing this Project could result in potential effluent treatability issues at the Mill in the future under a changed regulatory environment (*i.e.*, proposed changes to the PPERs).** Furthermore, the following additional potential benefits would not likely be realized:

- 1) meeting the proposed modernized PPERs;
- 2) complying with ECCC's directive on treated effluent quality;
- 3) reducing the amount of water drawn from the Spruce Lake Watershed; and
- 4) ensuring the Mill's environmental sustainability and economic viability.

For the above reasons, the null alternative is not a feasible option and was not considered further.

2.6.2 Project Location

Five locations in west Saint John were considered for constructing and operating the ETF (Figure 7):

- 1) Bald Mountain;
- 2) Gault Road;
- 3) Saint's Rest;
- 4) Mill West; and
- 5) Lee Cove.

Environmental constraints for each of these sites were assessed by *Fundy Engineering* [2017a]. A summary of that work is provided in Table 3. Based on the 2017 review, the Mill West site yielded the lowest assessment score related to potential environmental constraints while the Bald Mountain site yielded a close second. The Mill West site is a previously unused and undeveloped part of the overall Mill site. Conditions there (*i.e.*, exposed bedrock and / or located at a shallow depth) are optimal for siting the ETF.

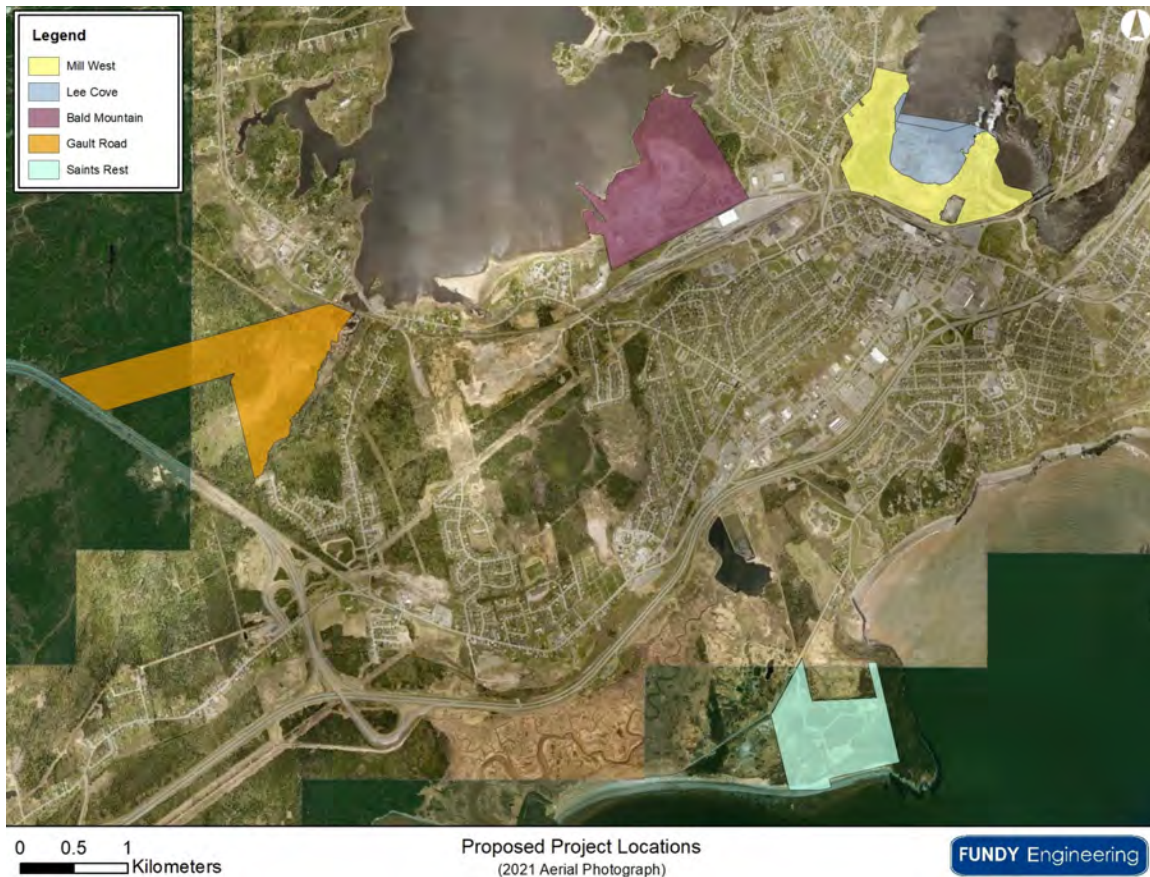

Figure 7. Locations considered for siting the environmental treatment facility for the Reversing Falls Mill in Saint John, New Brunswick.

Table 3. Summary of the potential environmental constraints for locations evaluated for siting the environmental treatment facility proposed for the Reversing Falls Mill in Saint John, New Brunswick.

PARAMETER	LOCATION									
	BALD MOUNTAIN		GAULT ROAD		SAINT'S REST		MILL WEST		LEE COVE	
	Details	Rating	Details	Rating	Details	Rating	Details	Rating	Details	Rating
LAND DETAILS										
Property Size and Ability to Host ETF	55024350, 2.95 ha 55024368, 4.27 ha 55006050, 22.33 ha 55183784, 11.1 ha 55024343, 22.54 ha	⚠️	00287748, 76.06 ha	🟢	55110910, 15.5 ha 55092001, 27.49 ha	⚠️	55162416, 48.7 ha (Mill Site) 55223739, 18 ha (Water Lot)	🟢	55223739, 18 ha (Water Lot) 55233001, 2.5 ha (Water Lot)	⚠️
Ownership	J.D. Irving Limited	🟢	J.D. Irving Limited	🟢	J.D. Irving Limited (55110910) Voyageur Properties Limited (55092001)	🟢	J.D. Irving Limited	🟢	J.D. Irving Limited	🟢
Zoning	Medium Industrial	🟢	Rural	⚠️	Pit and Quarry	🟢	Heavy Industrial	🟢	Heavy Industrial (55223739) and no zoning (55233001)	🟢
ENVIRONMENTAL CONSTRAINTS										
Protected Wellfields	Not within a protected wellfield; proposed ETF footprint is 1 025 m, 1 700 m, and 2 055 m from Zone C, Zone B, and Zone A, respectively, of the South Bay wellfield	🟢	Not within a protected wellfield; proposed ETF footprint is 225 m, 1 210 m, and 1 645 m from Zone C, Zone B, and Zone A of the South Bay wellfield, respectively	🟢	Not within a protected wellfield; proposed ETF footprint is 1 915 m, 1 665 m, and 1 340 m, respectively, from Zone A, Zone B, and Zone C of the South Bay wellfield	🟢	Not within a protected wellfield; proposed ETF footprint is 2 270 m, 2 860 m, and 3 170 m from Zone C, Zone B, and Zone A of the South Bay wellfield, respectively	🟢	Not within a protected wellfield; proposed ETF footprint is 3 380 m, 3 068 m, and 2 485 m, respectively, from Zone A, Zone B, and Zone C of the South Bay wellfield	🟢
Protected Watersheds	No constraints	🟢	No constraints	🟢	No constraints	🟢	No constraints	🟢	No constraints	🟢
Watercourses	None within the proposed ETF footprint and the layout is setback > 30 m from the banks of the Saint John River	🟢	None within the proposed ETF footprint and the layout is setback > 30 m from the watercourses present onsite	🟢	None within the proposed ETF footprint and the layout is setback > 30 m from the Bay of Fundy shoreline	🟢	None within the proposed ETF footprint and the layout is setback > 30 m from the banks of the Saint John River	🟢	Would be located within 30 m of the Saint John River	⚠️
Wetlands	None within the footprint of the proposed ETF and the layout is setback > 30 m from the wetlands present onsite	🟢	None within the footprint of the proposed ETF and the layout is setback > 30 m from the wetlands present onsite	🟢	None present on the properties	🟢	None present on the property	🟢	None present on the property	🟢
Provincially Significant Wetlands	No anticipated impacts to the small portion of a provincially significant wetland on one of the properties and / or its regulated 30 m buffer	🟢	Provincially significant wetlands present on the site and / or their regulated 30 m buffers could potentially be impacted by the Project and the pipeline going to and from the Reversing Falls Mill is shown passing through provincially significant wetlands; specific design measures could be implemented to potentially avoid any impact; however, at least one of those wetlands is > 2 ha in size	⚠️	None present on the properties	🟢	None present on the property	🟢	None present on the property	🟢
Flood Zones	Not located within a flood risk area	🟢	Not located within a flood risk area	🟢	Not located within a flood risk area	🟢	Not located within a flood risk area	🟢	Would be located on infilled land	⚠️

PARAMETER	LOCATION									
	BALD MOUNTAIN		GAULT ROAD		SAINT'S REST		MILL WEST		LEE COVE	
	Details	Rating	Details	Rating	Details	Rating	Details	Rating	Details	Rating
Environmentally Significant Areas	None located within 500 m of Project site; proposed ETF footprint 770 m from Dominion Park, 1 550 m from Greenhead Cave ESA, and 2 010 m from Reversing Falls & Outcrop Islands ESA		None located within 500 m of Project site; proposed ETF footprint 1 960 m from Saint's Rest Marsh & Beach ESA and 2 720 m from Dominion Park		Located within the Saint's Rest Marsh and Beach ESA; proposed ETF footprint 945 m from Manawagonish Island IBA, 965 m from Saint's Rest Marsh Beach, 1 610 m from Saint's Rest Marsh Nature Preserve, 1 610 m from Taylor's Island, and 2 035 m from the Irving Nature Park; permitting could prove a challenge due to possible impact to several potentially bird species protected by provincial and / or federal <i>Species At Risk Acts</i>		None located within 500 m of the Project site; proposed ETF footprint 550 m from Reversing Falls & Outcrop Islands ESA, 1 370 m from Dominion Park, 1 990 m from Carleton Martello Tower National Historic Site, 1 970 m from HMCS Brunswick, and 2 456 m from Greenhead Cave ESA		None located within 500 m of the Project site; proposed ETF footprint 415 m from Reversing Falls & Outcrop Islands ESA, 1 275 m from Dominion Park, 1 840 m from Carleton Martello Tower National Historic Site, 1 800 m from HMCS Brunswick, and 2 360 m from Greenhead Cave ESA	
Provincial and Federal Species at Risk	None within the footprint of the proposed ETF, but ground-truthing may show a presence; nearest observation is 1 770 m		None within the footprint of the proposed ETF, but ground-truthing may show a presence; nearest observation is 470 m		None within the footprint of the proposed ETF, but ground-truthing may show a presence		None within the footprint of the proposed ETF, but ground-truthing may show a presence; nearest observation is 700 m		None within the footprint of the proposed ETF, but ground-truthing may show a presence; nearest observation is 540 m	
OTHER POTENTIAL CONSTRAINTS										
Residential Receptors	420 m to nearest residence along Green Head Road; although the proposed ETF and nearest residence are at about the same elevation of about 12 m AMSL, a 20 m+ forested rock bluff exists between the proposed ETF and the nearest residential neighbourhood, which would camouflage the proposed ETF from view; a 300 m+ forested buffer exists between the nearest residence and the proposed ETF, which would help mitigate any nuisance odours and sound emissions		424 m to nearest residence on Gault Road; a 400 m+ forested buffer exists between the proposed ETF and the nearest residential neighbourhood, which combined with the proposed ETF being at an elevation slightly higher (i.e., 25 m versus 20 m AMSL) would eliminate any view of the proposed ETF and would help mitigate any nuisance odours and sound emissions		533 m to nearest residence on Sand Cove Road; several bluffs present between the residence and the proposed ETF combined with the 30 m elevation difference (proposed ETF would be higher) would eliminate any view of the proposed ETF and would help mitigate any nuisance odours and sound emissions		100 m to nearest residence on Millford Road; minimal (< 30 m) forested buffer exists between the proposed ETF and the nearest residential neighbourhood; the proposed ETF would be at a much lower elevation (i.e., 10 m AMSL compared to 40 m AMSL for the residences); although it would likely be highly visible, the lands have been the site of heavy industrial activity for > 100 years		260 m to nearest residence on Millford Road; moderate (~ 50 m) forested buffer exists between the proposed ETF and the nearest residential neighbourhood; the proposed ETF would be at a much lower elevation (i.e., 10 m AMSL compared to 30 m AMSL for the residences); although it would likely be highly visible, the lands have been the site of heavy industrial activity for > 100 years	
Pipeline Length	2 km each way		5.3 km each way; one auger bore would be required		4.4 km one way; up to four auger bores would be required		Located at Reversing Falls Mill site; no offsite pipeline required		Located at Reversing Falls Mill site; no offsite pipeline required	
Potential Onsite Contamination	Gravel pits are sometimes used to store contaminated materials; further investigation would be required to determine if any contaminated materials are present onsite		Gravel pits are sometimes used to store contaminated materials; further investigation would be required to determine if any contaminated materials are present onsite		There is an onsite containment cell for contaminated material; no others are known; the proposed ETF is adjacent to the cell		It is unlikely that there are any contaminated materials buried onsite in the area of the proposed ETF		Clean fill was used to infill the water lot historically	
Treated Effluent Outfall	The Mill's existing main outfall would be used to discharge treated effluent		The Mill's existing main outfall would be used to discharge treated effluent		An outfall would be constructed to discharge treated effluent to the Bay of Fundy near Sheldon Point		The Mill's existing main outfall would be used to discharge treated effluent		The Mill's existing main outfall would be used to discharge treated effluent	
RANK	2		3		4		1		3	

2.6.3 Treatment Technology

Conventionally, pulp and paper mills treat effluent using primary treatment (*i.e.*, gravity separation) and secondary treatment (*i.e.*, biological treatment) processes through one of the following methods:

- an Aerated Stabilization Basin (ASB) or basins;
- an Activated Sludge Treatment (AST) system; or
- an anaerobic system.

Currently, there are 75 pulp and paper mills across Canada (Figure 8). Of those mills, 32 use an AST system to treat their effluent (*i.e.*, 43 %), 26 use an ASB system (*i.e.*, 35 %), and 17 use a combination of AST and ASB or use alternative technologies, such as an anaerobic system (*i.e.*, 23 %).



Figure 8. Canadian pulp and paper mills active in 2017 (*n.b.*, active was determined based on mills reporting to the National Pollutant Release Inventory in 2017, the most recent year available) and their respective effluent treatment technology.

As noted above, the Reversing Falls Mill produces Kraft pulp. There are 26 Kraft mills operating in Canada and the majority of them (*i.e.*, 65 %) treat their effluent via an ASB. Similarly, 80 of the 95 Kraft mills operating in the United States use an ASB to treat their effluent.

For this Project, IPP considered six effluent treatment technologies, including:

- Aerated Stabilization Basin (ASB);
- Activated Sludge Treatment (AST);
- Moving Bed Biofilm Reactor (MBBR);
- Nutrient Limited Biological Activated Sludge (NLBAS);
- Sequential Biological Reactor (SBR); and
- Membrane Biological Reactor (MBR).

2.6.3.1 Aerated Stabilization Basin (ASB)

ASBs, as noted above, are a very common method of treating effluent in the forest products industry. Generally, this type of ETF comprises a primary clarifier coupled with a large aerated lagoon (Figure 11). The clarifier is used for primary treatment to help reduce and remove TSS and other particulate matter (*i.e.*, bark, dirt, and wood fibers) generated from the pulp and paper-making process. From the primary clarifier, the effluent flows to a large lagoon that contains microbes and nutrients, such as nitrogen and phosphorous, to further reduce the concentration of organic matter contained in the effluent.

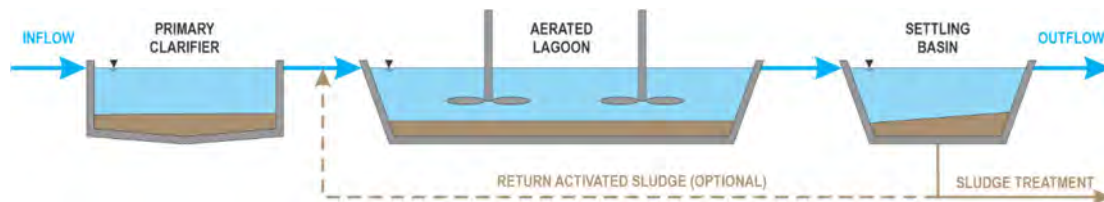

Figure 9. Simplified flow diagram of an aerated stabilization basin process used for treating effluent.

The aeration basin has a high retention time (*i.e.*, several days) and microorganisms in the aeration basin break down the organic matter contained in the effluent. Dissolved oxygen is supplied to the microorganisms by using large mechanical aerators installed throughout the basin. The aerators also constantly mix the microorganisms and organic matter throughout the lagoon. Remaining solids contained in the effluent settle out in the sedimentation basin where they are collected, dewatered, and sent for disposal. Although a very simplistic technology used by many pulp and paper mills (*i.e.*, refer to Figure 8), when compared to other treatment technologies, ASB by far requires the largest footprint and is often cited for odour issues.

2.6.3.2 Activated Sludge Treatment (AST)

The basic AST process, as illustrated in Figure 10, consists of the following components: a reactor in which microorganisms responsible for treatment are kept in suspension and aerated (*i.e.*, aeration tank); liquid-solids separation, usually in a sedimentation tank (*i.e.*, secondary clarifier); and a recycle system for returning solids removed from the liquid-solids separation unit back to the reactor (*i.e.*, return activated sludge).

An important feature of the AST process is the formation of flocculent settleable solids that can be removed by gravity settling in sedimentation tanks. The breakdown of the organic

matter contained in the wastewater occurs in the aeration tank. There, the organic matter comes into contact with microorganisms in the presence of dissolved oxygen long enough to permit the breakdown to occur. Dissolved oxygen is generally supplied through a diffused aeration system whereby compressors blow air from ports along the side walls and bottom of the tank. This ensures thorough mixing and suspension of the activated sludge.

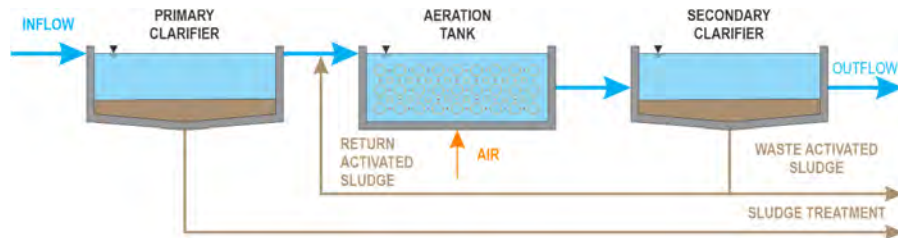

Figure 10. Simplified flow diagram of the activated sludge treatment process used for treating effluent.

Despite being a common method for treating pulp and paper effluents (*i.e.*, refer to Figure 8) largely for its compact design, AST is highly sensitive to operational variability and requires continuous monitoring and highly-skilled operators.

2.6.3.3 Moving Bed Biofilm Reactor (MBBR)

An MBBR is generally used upstream and downstream of a solids separation system, such as a clarifier (Figure 11). The upstream clarifier is used for primary treatment to help reduce and remove TSS and other particulate matter while the downstream clarifier is used for liquid-solids separation. The MBBR technology is a flow through fixed film biological process used for the treatment of municipal and industrial effluent. An MBBR is often used in the treatment of industrial effluents because of its ability to reduce soluble BOD by 90 %. The plastic carrier media (Figure 12) that the microbes grow on can freely move throughout the reactor due to mixing.

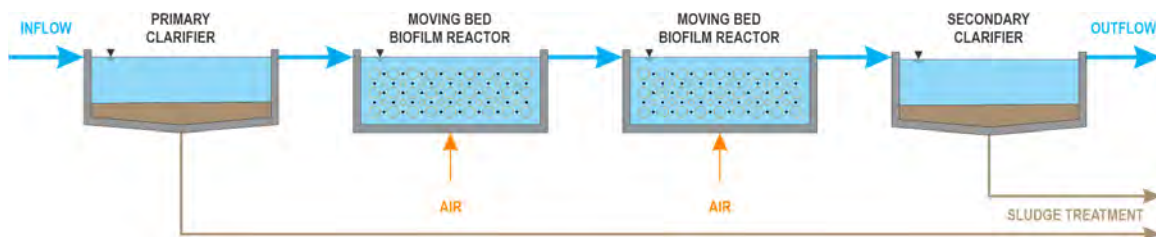

Figure 11. Simplified flow diagram of a typical moving bed biofilm reactor arrangement used for treating effluent.

The specially designed carrier media have an abundant surface area that the bacteria can grow and thrive on. Air required by the microbes is introduced through manifolds located at the bottom of the reactor (Figure 11). The air also provides the necessary mixing for maximum treatment within the reactor. The bacteria digest the organics contained in the effluent and convert it into biomass. As the biofilm becomes too thick to be supported on the carrier media and it falls off, new growth sites become available. Screens placed at the inlet and outlet to the reactor ensure that the carrier media are contained (*n.b.*, the interaction of the carrier media with the screens through the internal turbulence ensures they are kept clean).

Bacteria grow in multiple layers on the carrier media allowing the MBBR to be very robust and self-regulating due to load swings, temporary load deprivation, and upset events. For example, if an upset event occurs, not all layers of bacteria will be affected, which allows the system to recover faster than compared to other systems.

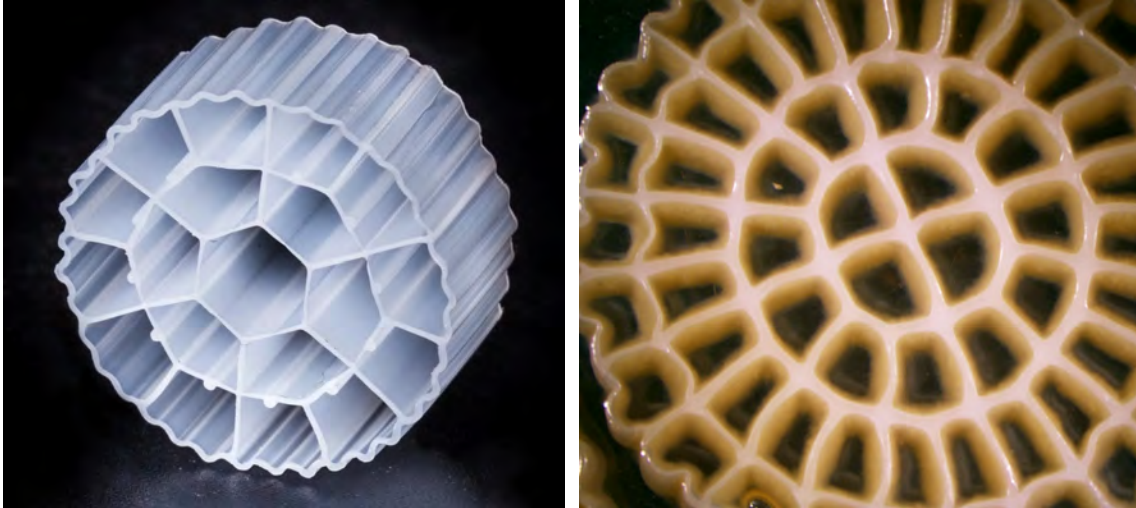

Figure 12. Examples of plastic carrier media used within a moving bed biofilm reactor to support bacteria growth.

MBBRs are one of the most compact technologies currently available for achieving treatment. IPP has operated an MBBR as part of its pollution reduction strategy (*i.e.*, refer to Section 2.2.1) since 2000. A significant advantage of the MBBR technology is that it has a compact footprint and yields low sludge volumes compared to other available options.

2.6.3.4 Nutrient Limited Biological Activated Sludge (NLBAS)

The nutrient limited biological activated sludge effluent treatment process is similar to the MBBR except that one of the reactors is swapped out for an AST tank (*c.f.*, Figure 11 and Figure 13). The aeration tank acts similar to the MBBR except that there are no carrier media present. Instead, the sludge (*i.e.*, microorganisms) freely move about the tank. Similar to the MBBR, air is introduced to the aeration tank from manifolds along the bottom, which ensures thorough mixing and suspension of the activated sludge. A recycle system is used for returning solids (*i.e.*, return activated sludge) removed from the secondary clarifier back to the reactor.

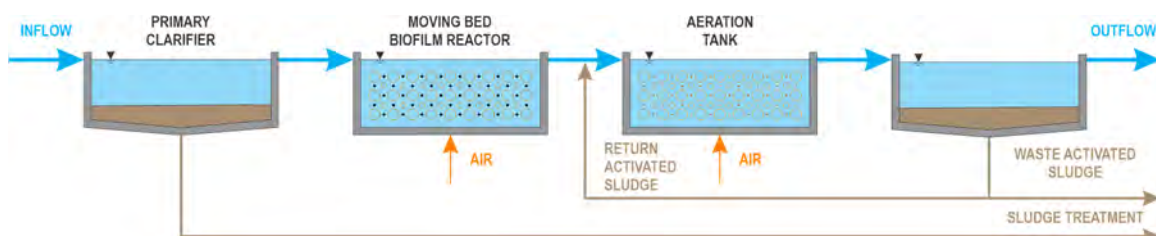

Figure 13. Simplified flow diagram of a nutrient limited biological activated sludge arrangement used for treating effluent.

Comparatively, NLBAS generates low volumes of sludge; however, this technology requires a large footprint for the AST and it is difficult to control the treatment process.

2.6.3.5 Sequential Biological Reactors (SBR)

SBRs are a variant of AST technology. Through this technology, all stages of a conventional AST system occur in the same tank in the form of a batchwise process (*i.e.*, two or more reactors operating in a predetermined sequence of operations). Typically, the SBR performs five sequential steps (Figure 14):

- 1) filling, where effluent is introduced to the tank until it is full;
- 2) bioreaction, the full tank is aerated using fixed or floating mechanical pumps or by transferring air into fine bubble diffusers fixed to the floor of the tank;
- 3) settling, where the aeration is halted and suspended solids can settle out;
- 4) decanting, where the supernatant is slowly drawn out of the tank; and
- 5) idling, which allows for variations in effluent flow.

A specified period of time occurs between each step and the system is generally operated continuously by having multiple reactors so that when one reactor finishes the filling stage the next one is ready to begin filling.

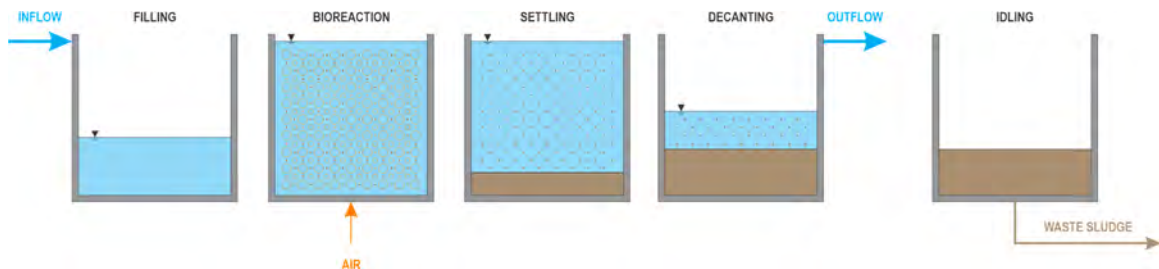

Figure 14. Simplified flow diagram of a single sequential batch reactor showing the five steps used for treating effluent.

As inferred from above, this is a highly automated technology with a complex design. It is sometimes selected for treating various types of effluent because it has a compact footprint and discharges intermittently to the receiving environment. Furthermore, it has a low sensitivity to operational variability because the effluent is treated in batches.

2.6.3.6 Membrane Biological Reactor (MBR)

An MBR is an activated sludge effluent treatment process with a membrane technology, such as microfiltration or ultrafiltration, added as a secondary settling tank (Figure 15). There are two membrane configurations used in the industry: 1) internal / submerged / immersed (*i.e.*, the membranes are immersed in and integral to the bioreactor); and 2) external / sidestream (*n.b.*, Figure 15 shows an external configuration). As the effluent flows through the membrane, the microbes and dissolved materials are filtered out.

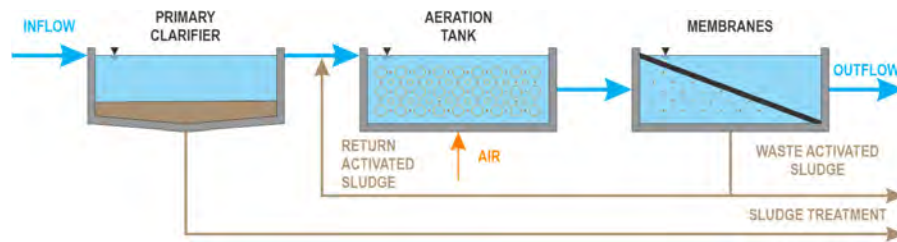

Figure 15. Simplified flow diagram of a membrane biological reactor system used for treating effluent.

Although MBRs are highly compact, the membranes lack robustness meaning there is little flexibility for operational variability.

2.6.3.7 Treatment Technology Review, Assessment, and Selection

2.6.3.7.1 Site Visits

The Project team visited several pulp and paper mills to review the different treatment technologies employed. Several in-person site visits and two virtual site visits were conducted at some of the world's newest mills and those with the newest effluent treatment facilities (Figure 16).



Figure 16. Sites visited by the Project team to experience and observe some of the effluent treatment technologies used at pulp and paper mills.

Alberta Pacific opened Canada's newest Kraft mill in 1993. That mill, which is located in Boyle, Alberta, operates an AST. Other mills visited that operate ASTs are shown in Figure 16.

Södra operates one of the world's largest and most modern Kraft mills. Their mill in Värö, Sweden was completely rebuilt in 2016 and operates an NLBAS effluent treatment system. Europe's most modern Kraft pulp Mill is operated by Mercer Stendal in Arneburg, Germany. Mercer Stendal's pulp mill was opened in 2004 and also operates an AST. MBBR systems visited virtually include the Vallviks Bruk AB mill in Sweden and the CMPC Mill in Chile (Figure 16).

Visits to those other mills were invaluable to the team who were able to experience and observe the various treatment technologies first hand (*i.e.*, see, smell, and hear). During the visits, the team had an opportunity to discuss the pros and cons of the treatment facilities with the operators. That information was brought back to Saint John and helped inform the technology selection for the ETF.

2.6.3.7.2 Technology Comparison

There are several industry advantages and disadvantages summarized in Table 4 associated with each of the technologies considered. The Project team considered these when evaluating the different technologies.

Table 4. Industry advantages and disadvantages of the effluent treatment technologies considered for the Reversing Falls Mill in Saint John, New Brunswick.

Technology	Industry Observed Advantages	Industry Observed Disadvantages
Aerated Stabilization Basin (ASB)	<ul style="list-style-type: none"> ➤ Simple technology ➤ Considerable industry experience ➤ Low capital and operating costs ➤ Low sensitivity to operational variability 	<ul style="list-style-type: none"> ➤ Large footprint for high residence times ➤ Viewed as inferior technology ➤ Odours can be an issue ➤ Lower BOD reductions ➤ Periodic dewatering and sludge removal required
Activated Sludge Treatment (AST)	<ul style="list-style-type: none"> ➤ Compact footprint ➤ Highly automated ➤ Flexible for nutrient removal ➤ Sludge recycling 	<ul style="list-style-type: none"> ➤ Complex design and operation require regular testing and highly skilled operators ➤ Highly sensitive to operational variability ➤ Moderate capital and operating costs ➤ Requires nutrient addition
Moving Bed Biofilm Reactor (MBBR)	<ul style="list-style-type: none"> ➤ Simple design and operation ➤ Compact footprint ➤ Robust ➤ Experience at IPP since 2000 	<ul style="list-style-type: none"> ➤ High operating costs ➤ Applied less in industry
Nutrient Limited Biological Activated Sludge (NLBAS)	<ul style="list-style-type: none"> ➤ Low operating costs ➤ Low sludge generation ➤ Considerable industry experience ➤ Low sensitivity to operational variability 	<ul style="list-style-type: none"> ➤ Large footprint ➤ Large capital cost ➤ Difficult to control treatment process
Sequential Batch Reactors (SBR)	<ul style="list-style-type: none"> ➤ Compact footprint ➤ Highly automated ➤ Flexible for nutrient removal ➤ Low sensitivity to operational variability 	<ul style="list-style-type: none"> ➤ Complex design ➤ Intermittent discharge
Membrane Biological Reactor (MBR)	<ul style="list-style-type: none"> ➤ Compact footprint ➤ Minimal industry experience 	<ul style="list-style-type: none"> ➤ Membrane's lack of robustness ➤ Membrane's lack of flexibility to operational variability

2.6.3.7.3 Needs and Wants Assessment

IPP developed a list of needs and wants for selecting the ETF technology. The ETF technology needs included:

- meets or exceeds existing PPERs;
- meets or exceeds the proposed modernized PPERs;
- limits toxicity risks;
- minimizes risk of odour impact to neighbours; and
- fits entirely on the Mill site.

Three technologies failed the needs assessment: ASB; AST; and MBR (Table 5). IPP did investigate the use of ASB technology in the early 1990s at an offsite location, Sheldon Point, but opted instead to go with the pollution prevention strategy described in Section 2.2.1. Although the pulp and paper mills operating in North America that use ASB technology meet all current relevant regulations [McCubbin Consultants, 2015], conventional ASB systems would likely be incapable of treating effluent to the limits under the proposed modernized PPERs. As noted above, ASB and AST technologies use aeration to treat effluent. In both instances, lagoons required to treat the flow from the Mill would be too large to fit on the Mill site. Furthermore, the technologies would likely result in odour complaints from nearby residents. MBR technology is still immature and it is not believed that it could treat effluent to the limits under the proposed modernized PPERs.

The technologies that failed the needs assessment did not advance to the wants ranking. Only MBBR, NLBAS, and SBR technologies were ranked with respect to 14 criteria listed in Table 5. Based on the assessment, MBBR was ranked well above the other two technologies that were similarly ranked.

Table 5. Comparison of effluent treatment technologies considered for the Reversing Falls Mill in Saint John, New Brunswick.

Environmental Treatment Facility Objective	Treatment Technology					
	ASB	AST	MBBR	NLBAS	SBR	MBR
<u>NEEDS ASSESSMENT</u>						
Meets existing PPERs:						 (immature technology)
Meets or exceeds proposed modernized PPERs:						
Limits toxicity risks: (sensitive to toxicity)						
Minimizes odour risk to neighbours:						
Fits on the Mill site:						
<u>WANTS RANKING (LOWER NUMBER = BETTER; POSSIBLE RANKING OF 1 THROUGH 4)</u>						
Meets monthly BOD _{TOTAL} limits:	DID NOT MEET NEEDS ASSESSMENT	DID NOT MEET NEEDS ASSESSMENT	2	1	2	DID NOT MEET NEEDS ASSESSMENT
Meets monthly TSS limits:			2	3	2	
Meets monthly COD limits:			1	1	1	
Meets anticipated monthly phosphorous limits:			2	3	2	
Meets anticipated monthly nitrogen limits:			1	2	3	
Meets pH control limits:			1	1	1	
Meets anticipated monthly temperature limits:			1	1	1	
Toxicity control:			1	2	3	
Control Mill upsets (flow / load):			2	1	2	
Control ETF upsets (power failures, solid excursions):			2	1	2	
Ability to rebound from upsets:			1	3	1	
Ease of maintenance:			1	2	2	
Ease of inspection:			1	2	1	
Ease of operation:	1	3	4			
RANK				1 (19)	2 (26)	3 (27)

2.6.3.7.4 Pilot Plants

Pilot plants were built and operated at the Mill (Figure 17 and Figure 18) to further evaluate the two highest ranked technologies (*i.e.*, MBBR and NLBAS). SBR technology was not selected for pilot plant assessment because of the complex design and intermittent discharge experienced with that technology. The intermittent discharge was considered incompatible for the Mill's process water flows, which are continuous.



Figure 17. Photograph showing the moving bed biofilm reactor pilot plant that was operated at the Reversing Falls Mill in Saint John, New Brunswick.

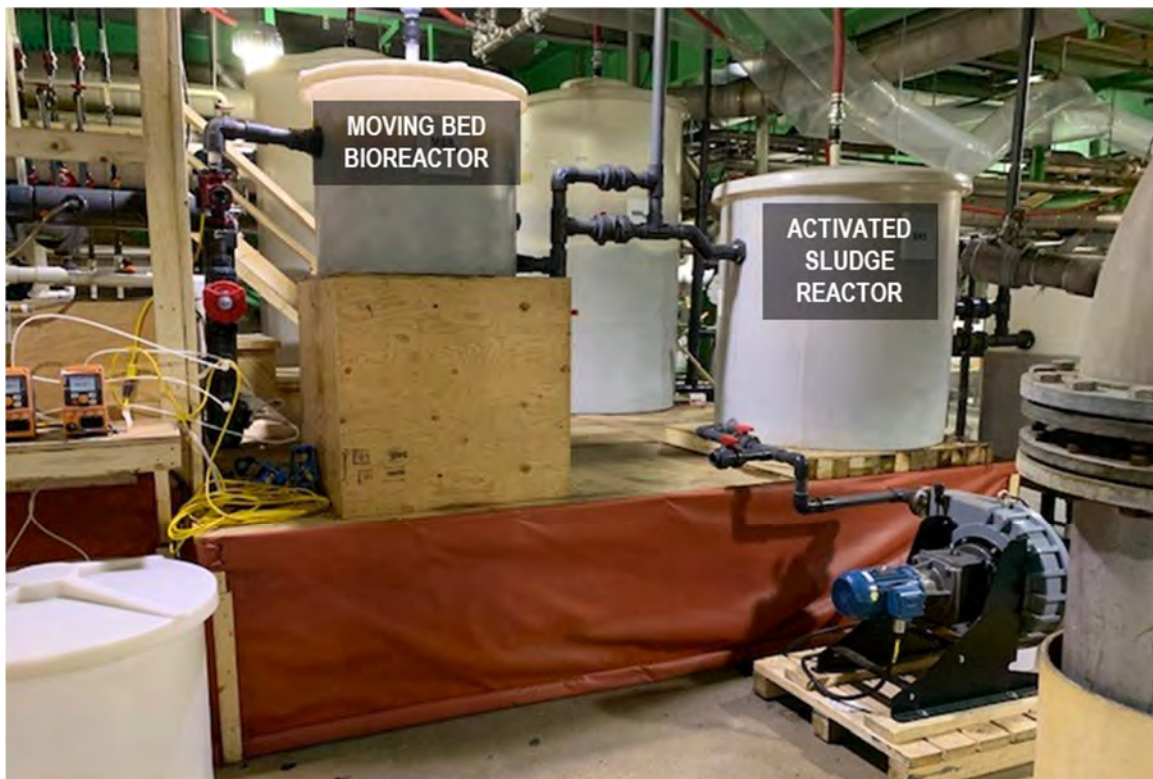

Figure 18. Photograph showing the nutrient limited biological activated sludge pilot plant that was operated at the Reversing Falls Mill in Saint John, New Brunswick.

The pilot plants were built side-by-side at the Mill and began operating in February 2020. They were operated for most of 2020 by a dedicated full-time process engineer and laboratory technician. The pilot plants were supplied the Mill's process water from the same equalization tank. Daily monitoring of BOD, COD, TSS, nutrient concentrations, toxicity, pH, conductivity, and temperature was undertaken to compare performance. Analysis showed performance was similar for both plants. Bump tests were initiated on both pilot plants to assess their response to upset conditions and results were similar with recovery occurring within one to three days.

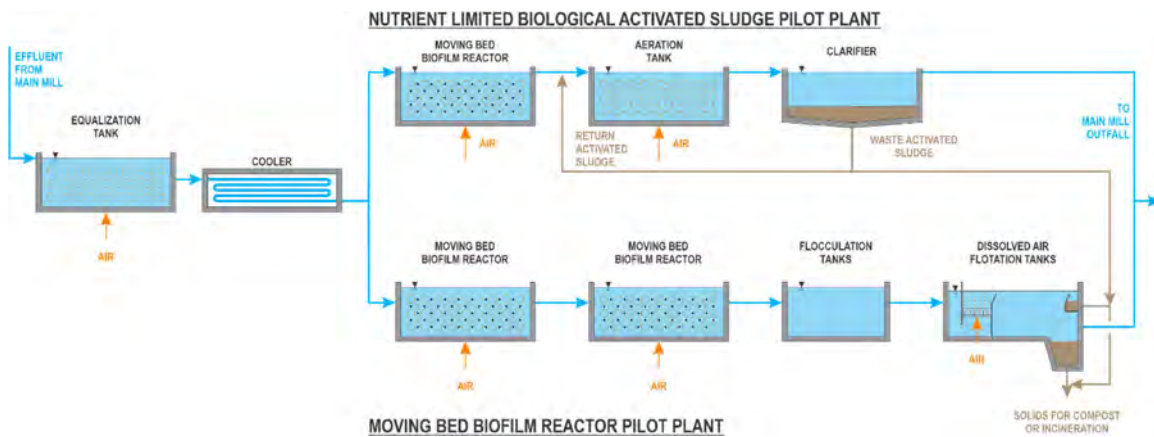

Figure 19. Simplified flow diagram of the two pilot plants operated at the Reversing Falls Mill in Saint John, New Brunswick.

Operation of the pilot plants showed that both technologies are capable of meeting all future regulations with more concentrated effluent (*i.e.*, through the water use reduction project).

2.6.3.7.5 Technology Selected

The MBBR was the clear leader of the two technologies piloted for the following reasons:

- easier to operate;
- recovers faster from upsets;
- uses tanks with a smaller footprint;
- uses smaller clarification units;
- integrates well within the existing pollution prevention systems; and
- IPP understands the technology well as a small MBBR is currently operated as a component of the pollution prevention strategy described in Section 2.2.1.

2.7 PROJECT DETAILS

The main steps in the manufacturing of pulp at the Mill are: woodchip cooking; brown stock washing; bleaching; and drying. Large volumes of water are used throughout the course of manufacturing for various processes and cooling. The major Project components shown in Figure 20 will be used to improve quality of the treated effluent discharged to the Saint John River and to reduce the volume of water required in the manufacturing process. Those major components are described in the sections below.



Figure 20. Major components of the environmental treatment facility and water use reduction project proposed for the Reversing Falls Mill in Saint John, New Brunswick.

2.7.1 *Environmental Treatment Facility*

The main components of the ETF (Figure 21) include:

- a diversion tank;
- an equalization tank;
- a primary gravity clarifier;
- two indirect air coolers;
- an elevated walkway;
- two moving bed biofilm reactors;
- a landscaped berm; and
- a process building that will house:
 - mechanical and electrical equipment;
 - pumps;
 - blowers;
 - four dissolved air flotation clarifiers;
 - nutrient adjustment;
 - chemical storage;
 - solids dewatering;
 - laboratory space;
 - offices and personnel spaces; and
 - control room.



Figure 21. General layout and main components of the environmental treatment facility proposed for the Reversing Falls Mill in Saint John, New Brunswick. The numbers follow the effluent through the treatment process.

A simple flow diagram for the ETF is shown in Figure 22. Preliminary design drawings for the ETF are provided in Appendix IV. The tentative base floor elevations (*n.b.*, elevations may change slightly during detailed engineering design) and the top of structure elevations for the main components of the ETF are summarized Table 6.

Table 6. Tentative elevations for the main components of the environmental treatment facility proposed for the Reversing Falls Mill in Saint John, New Brunswick.

Structure	Base Elevation (m)*	Height (m)	Top Elevation (m)*
Diversion tank	7.3	4.6	11.9
Equalization tank	23.3	9.8	33.1
Indirect air coolers	27.2	7.6	34.8
Primary clarifier	30.3	4.8	35.1
MBBR 1	31.8	9.3	41.1
MBBR 2	30.3	9.3	39.6
Process building	23.3	19.5	42.8

NOTES:

*Elevation with respect to Mill datum

The tanks and the ETF process building will be built onsite while the majority of the equipment will be mounted on skids and delivered directly to the site from the manufacturing facilities.

Once the ETF is in operation, all existing in-Mill pollution prevention equipment, save for the MBBR, will remain in service including the reverse osmosis system. The existing MBBR will no longer be required. As a result, that MBBR will be taken out of service.

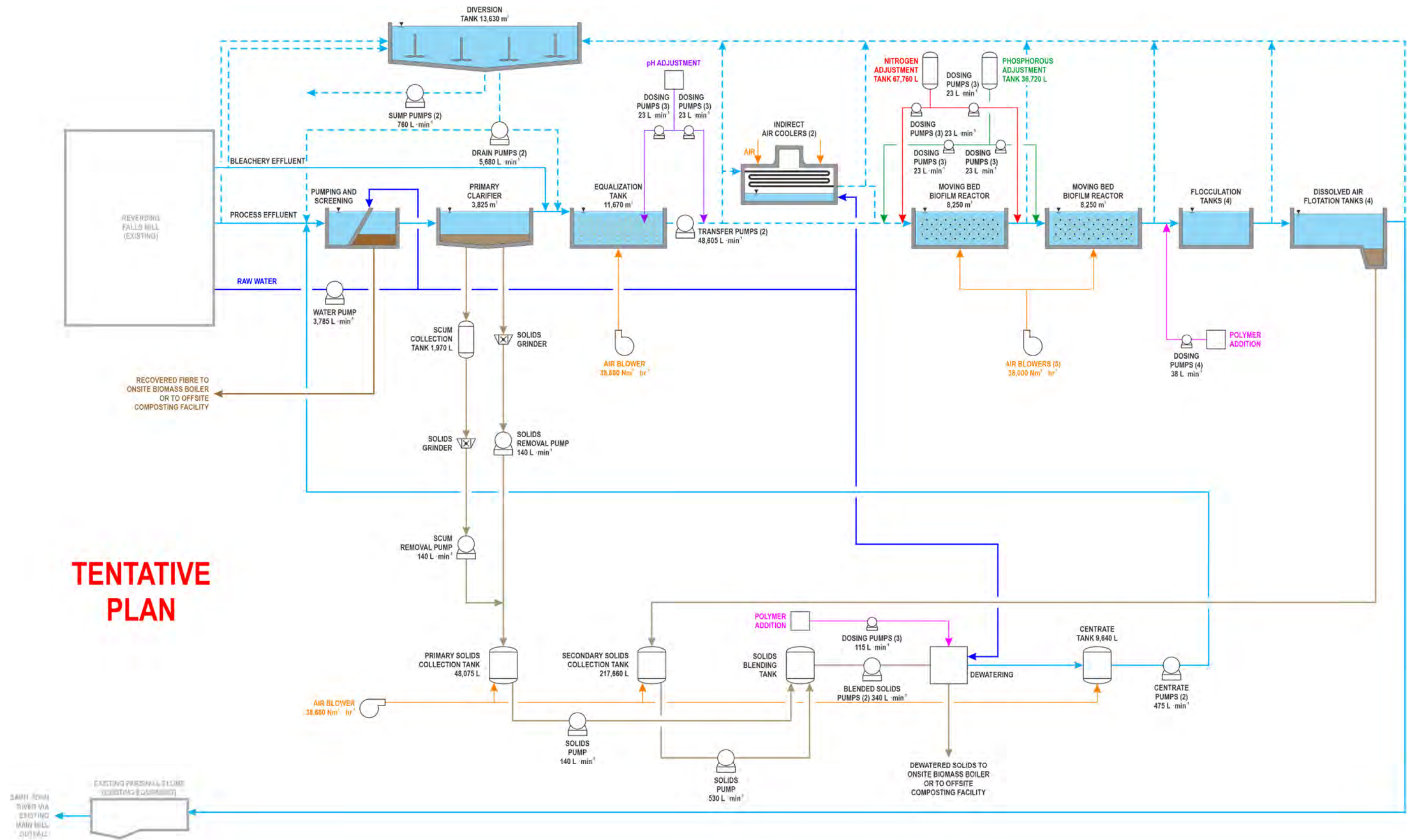

Figure 22. Simple flow diagram for the environmental treatment facility proposed for the Reversing Falls Mill in Saint John, New Brunswick. Equipment shown with black lines is proposed while that shown in thick grey is existing.

2.7.1.1 Design Parameters

Additional projects proposed at the Mill as part of routine upgrades may have an impact on the quantity and quality of the effluent requiring treatment. For example, the water use reduction component of the Project described in Section 2.2.2 will reduce the effluent flow by about half; however, the BOD / COD loading will be doubled as a result. With regulatory approval, the production rate of the Mill is also forecasted to increase within the next decade.

2.7.1.1.1 Flows and Loading

Accounting for the planned upgrades and changes at the Mill, the flow and feed loading design criteria used for the ETF upstream of the existing in-Mill treatment systems are provided in Table 7. These predicted feed values are based on four years of data collected at the Mill from 2017 to 2020. The maximum and minimum loadings were considered in the overall design. The technology selected for treatment is robust enough to accommodate a broad range of flows and concentrations. For example, the flow through the MBBR and the amount of media can be adjusted for optimal treatment.

Table 7. Flow and loading criteria used for designing the environmental treatment facility at the Reversing Falls Mill in Saint John, New Brunswick. These predicted feed values are based on four years of data collected at the Mill from 2017 to 2020.

Parameter	Average (year)	Maximum (year)
Flow ($\text{m}^3 \cdot \text{day}^{-1}$)	70 000	91 000
$\text{COD}_{\text{TOTAL}}$ ($\text{kg} \cdot \text{day}^{-1}$)	68 500	137 000
BOD_5 ($\text{kg} \cdot \text{day}^{-1}$)	24 400	44 200
TSS ($\text{kg} \cdot \text{day}^{-1}$)	8 000	16 000
Summer Average Temperature ($^{\circ}\text{C}$)	49	60
Winter Average Temperature ($^{\circ}\text{C}$)	49	50

The vendor modelled their treatment system design using the feed and loading data provided in Table 7 and the results obtained through operation of the onsite MBBR pilot plant.

2.7.1.1.2 Regulatory Discharge Limits and Performance Discharge

Current effluent discharge from the Mill is compared to the current regulatory discharge limits (*i.e.*, 1992 PPERs) in Table 8. Presently, BOD_5 , TSS, and $\text{COD}_{\text{TOTAL}}$ per tonne of production are all below the current regulatory discharge criteria. For example, the existing monthly average for BOD_5 is $5.6 \text{ kg} \cdot \text{t}^{-1}$, which is $1.9 \text{ kg} \cdot \text{t}^{-1}$ less than the regulatory limit.

When the ETF is brought online, the predicted discharge will meet or exceed the anticipated regulatory criteria for all parameters (Table 8). For example, it is anticipated that the monthly average regulatory limit for BOD_5 will decrease to $2.6 \text{ kg} \cdot \text{t}^{-1}$ and the maximum monthly average from the ETF will be $1.5 \text{ kg} \cdot \text{t}^{-1}$.

Table 8. Current effluent discharge from Reversing Falls Mill in Saint John, New Brunswick compared to the current regulatory discharge limits. Also included are the predicted effluent discharge criteria for the environmental treatment facility and the proposed modernized regulatory discharge limits.

Parameter	Units	1992 PPER Limits		Current Discharge		Proposed Modernized PPER Limits		Predicted ETF Discharge*	
		Daily Maximum	Monthly Average	Maximum Daily Maximum	Maximum Monthly Average	Daily Maximum	Monthly Average	Maximum Daily Maximum	Maximum Monthly Average
BOD ₅	kg · t ⁻¹	12.5	7.5	10.6	5.6	4.25*	2.6*	2.0	1.5
	kg · day ⁻¹	16 788	10 073	9 189	6 352	4 998	3 054	2 700	2 050
TSS	kg · t ⁻¹	18.75	11.25	10	6.8	6.25*	3.75*	1.5	1.4
	kg · day ⁻¹	25 181	15 109	12 763	8 496	7 525	4 515	2 000	1 800
COD _{TOTAL}	kg · t ⁻¹	N/A	N/A	39.7	24	75*	45*	22.3	18.6
	kg · day ⁻¹	N/A	N/A	40 071	28 213	85 663	51 398	30 000	25 000

NOTES:

*The predicted discharge was provided by the vendor(s) based on treatment system modelling that included results obtained during the pilot plant operation at the Mill

PPER = Pulp and Paper Effluent Regulations

ETF = Environmental Treatment Facility

N/A = Not Applicable

*Mills that are designed to operate a recovery boiler, a lime kiln, or a pulping digester

2.7.1.2 Mill Process Tie-Ins

Future tie-ins for the ETF include the West Side Lift Station (WSLS) for the Mill's process effluent, the equalization tank for the bleachery effluent, and the existing Parshall flume located upstream of the Main Mill Outfall (MMO) for the treated effluent (Figure 22).

2.7.1.2.1 West Side Lift Station

The WSLS (Figure 21) will be constructed at the Mill in 2022 / 2023 and is part of an ongoing program to modernize the effluent collection system. Although the WSLS will support the operation of the future ETF, it is required regardless to help reduce the risk of spills and / or exceedances in effluent quality at the Mill. It is also required for a tie-in near the MMO and underground piping to and from the Mill and represents the starting point for sending effluent to the new treatment facility for further refinement. Effluent piping will extend from the WSLS to the ETF.

2.7.1.2.2 Piping

The Mill will be connected to the ETF through a series of underground pipes. Those pipes will be installed within a granular bedding material placed either below an asphalt, concrete, or gravel roadway or beneath a sod, hydroseed, or gravel right-of-way. The bleachery effluent and all other process effluent (*i.e.*, mill process effluent) lines going to the ETF will be 600 mm and constructed of High-Density PolyEthylene (HDPE). The effluent line extending from the ETF to the existing Parshall flume upstream of the existing Mill's MMO will be 900 mm and constructed of HDPE.

2.7.1.3 Pre-Treatment

The Mill's process effluent will undergo pre-treatment, as described below, to remove bulk items that could impact the overall treatment process (Figure 22).

2.7.1.3.1 Screening

A coarse screen will be installed at the WSLS (Figure 20 and Figure 22) to remove any debris that could damage equipment of the ETF, such as pumps. A single travelling screen (*i.e.*, 6 mm round holes) is proposed. The screen panels will be carried on heavy-duty stainless steel chains and will be operated in a shelf configuration to give the unit the ability to remove larger screenings (*i.e.*, unmattable items) and to increase the effective screening area. The travelling screen will be continuously cleaned using a combined spray and mechanical high-speed brush wash system. Sensors on the travelling screen will be used to identify if there are any blockages. Should a blockage be identified and the unit needs to be taken offline, the screen can be bypassed.

The screening system will have a volumetric capacity of $11.7 \text{ m}^3 \cdot \text{hr}^{-1}$. The screened material will be routed to a screw compactor where the material will be dewatered and compacted. The compactor water will have a loading capacity of about $2 \text{ m}^3 \cdot \text{hr}^{-1}$. The recovered and compacted material will either be sent to the onsite biomass boiler or an offsite compost facility.

2.7.1.4 Primary Treatment

For the first stage of the ETF, the Mill's process effluent will be directed to primary treatment as described below.

2.7.1.4.1 Primary Gravity Clarifier

IPP's engineering team considered all technologies for solids separation when designing the ETF. The most effective clarification technology was selected for primary clarification. Solids contained in the initial flow to the ETF settle easily via gravity. Therefore, gravity settling was selected for primary clarification. This is the initial settling method used at the two Mill's visited that employ MBBRs (*i.e.*, refer to Section 2.6.3.7.1).

The Project will involve building and operating a single 3 825 m³ (*i.e.*, 35.1 m diameter 4.6 m tall with 0.6 m of freeboard) primary gravity clarifier (Figure 21, Figure 22, and Figure 23). The primary gravity clarifier will predominantly provide protection to the ETF during Mill shutdowns. Mill process effluent will enter the primary clarifier through ports in the top of a central vertical pipe and from there it will flow radially to a peripheral effluent weir (Figure 23). The influent well will direct flow downward to reduce short-circuiting across the top of the clarifier. A collector arm located at the bottom of the clarifier will rotate very slowly and a series of rakes will push settled solids to a solids draw-off at the centre of the tank. Floating solids migrating toward the edge of the tank will then be retained by a baffle located in front of the weir. A surface skimmer attached to the collector arm will collect scum from the surface and push it into a scum box that drains outside the tank well. The goal of the primary gravity clarifier will be to reduce the effluent TSS to < 60 mg · L⁻¹.

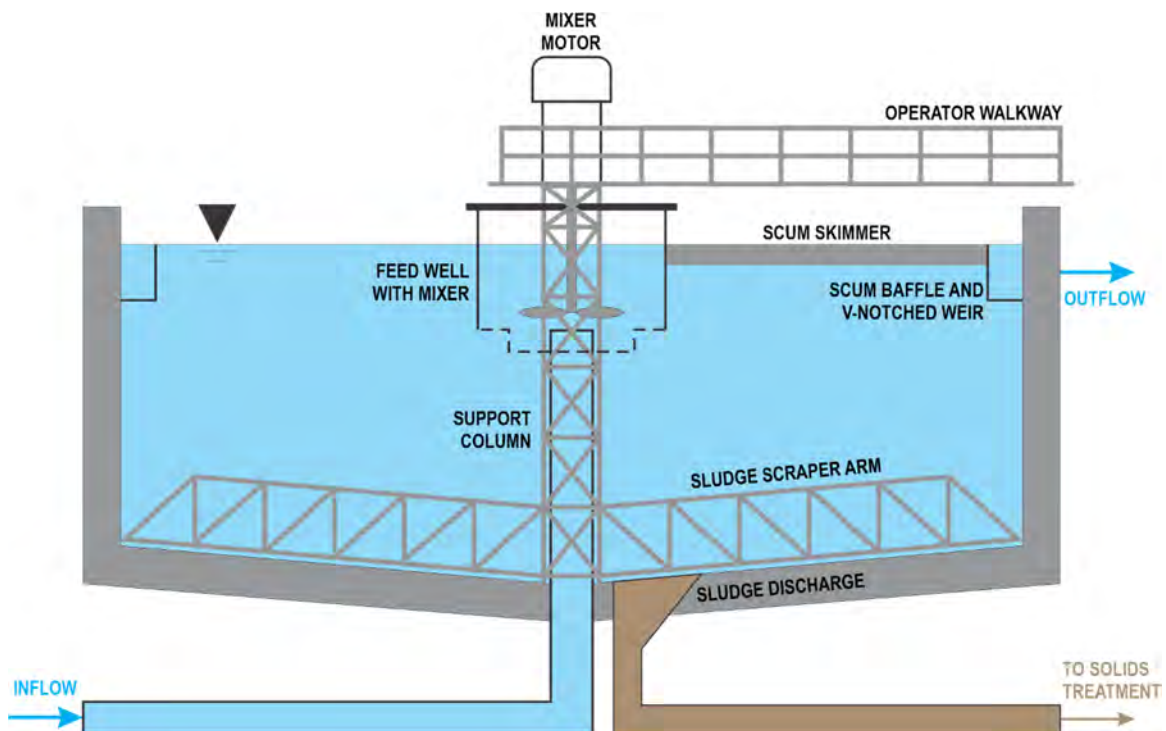

Figure 23. Cross-section of a typical primary gravity clarifier.

As noted previously, IPP has an extensive spill containment system on site, which allows fibre recovery and ultimately reduces the TSS that will be sent to the ETF. There is a high fibre recovery within the Mill's bleachery effluent stream and further TSS separation is not required, so under normal circumstances it will be directed to the equalization tank (Figure 22). In contrast, the Mill's process effluent stream, has a highly variable TSS concentration, so it will be directed upstream of the primary gravity clarifier. Effluent collected in the Mill's diversion tank, which may contain high TSS concentrations due to being a mixture of bleachery and process effluent, will be directed upstream of the primary clarifier. The centrate produced during the solids dewatering processes will also be directed upstream of the primary gravity clarifier because of its high TSS concentration.

The primary gravity clarifier will have a retention time between 3 hours and 6 hours and is expected to have a removal efficiency for settable TSS and TSS_{Total}, respectively, of > 85 % and 50 %. Preliminary operational performance data for the primary gravity clarifier is provided in Table 9.

The unit will have two full length solids rakes and two one-third length solids rakes at the bottom of the tank and one full length skimmer at the surface of the tank (Figure 21). The rakes and skimmer will be powered by two 1.5 kW motors. No chemical dosage is anticipated for the primary gravity clarifier; however, space will be reserved in the polymer room of the main ETF process building if dosage is necessary in the future.

Solids from the primary gravity clarifier will be directed to the primary solids tank in the ETF process building using a 3.7 kW, 1 200 RPM, 140 L · min⁻¹ solids removal pump (Figure 22). Solids removal will occur using a flow control based system that operates when the solids height reaches a level pre-determined by the operator. A solids grinder will be located upstream of the solids removal pump to minimize the risk of a blockage. Full flushing functionality will be incorporated to clear the solids removal piping upstream and downstream of the solids grinder and the solids removal plump.

Table 9. Preliminary operational performance of the primary gravity clarifier proposed for the environmental treatment facility at the Reversing Falls Mill in Saint John, New Brunswick.

Parameter	Average	Maximum
Flow (m ³ · day ⁻¹)	28 000	44 000
Inflow TSS (kg · day ⁻¹)	3 000	10 000
Retention time (min)	198	126*
Load (m ³ · m ⁻² · day ⁻¹)	28.9	45.5

Notes:

*At maximum flow

Surface scum collected from the primary gravity clarifier will be routed to a 1 970 L scum collection tank (Figure 22). From there, the collected scum will pass through a grinder and be pumped using a 3.7 kW, 1 200 RPM, 140L · min⁻¹ pump to the primary solids tank where it will help keep particles in suspension. Level control in the scum collection tank will be a simple high / low batch process.

2.7.1.4.2 Equalization Tank

The Kraft pulping process involves variations in effluent flow rate, organic load, and pH (*n.b.*, on average, pH of the effluent is above 7). Incorporating an Equalization (EQ) tank in the ETF will reduce those variations, provide some buffering of slug loads and upset events, prevent equipment oversizing, and allow for a small amount of treatment. The equalization tank will also provide an area where the bleachery and process effluent streams can mix together to homogenize the pH levels.

The 11 670 m³ (*i.e.*, 41.5 m diameter and 9.8 m tall with 1.1 m of freeboard; Figure 21 and Figure 22) concrete (*n.b.*, depending on market conditions, the tank may be constructed from stainless steel) EQ tank will provide total hydraulic retention time of four hours at the average effluent flow rate (*i.e.*, 28 000 m³ · day⁻¹). Normally, the EQ tank will operate at around 50 % of its total capacity, which will provide a two hour retention time to buffer pH, organic (*i.e.*, BOD and COD), and flow variations.

Three (*i.e.*, two duty and one standby) 298 kW, 1 200 RPM, 48 605 L · min⁻¹ centrifugal effluent pumps will, depending on the temperature, either direct the effluent to the wet air coolers or directly to the MBBRs (Figure 22). Because the effluent pH may vary the pumps will be constructed of duplex stainless steel. The pumps will be operated by a variable frequency drive on flow control. A remote setpoint will be from the EQ tank level using a gap control concept (*i.e.*, once the level reaches the setpoint, the pumps will turn on and will only turn off when the level drops below the setpoint).

To ensure adequate mixing and to prevent the establishment of anaerobic conditions in the EQ tank, aeration will be provided by a blower through a Big Air Bubble (BAB) mixing system (Figure 22). A number of small BAB units will ensure better mixing in all conditions. A total of 77 BAB mixers, producing a combined air flow of 720 to 1 280 Nm³ · hr⁻¹, will keep the EQ tank homogenized and reduce variations in effluent quality. A 250 kW, 38 680 Nm³ · hr⁻¹ blower will supply the air to the EQ tank.

The blowers will be housed in a mechanical room of the ETF process building. That mechanical room will be insulated to help mitigate the sound emissions from the air blowers.

2.7.1.4.2.1 pH Correction

As noted previously, pH of the effluent can vary considerably; however, pH spikes are of relatively short-lived (*i.e.*, < 30 min). Generally, the EQ tank will be able to reduce pH spikes to an acceptable range for biological treatment (*i.e.*, 6.5 to 8). In some instances, the EQ tank may not be able to provide buffering of pH spikes. Therefore, the EQ tank will have two pH control points (Figure 22). A trim pH adjustment will be located between the two sections of the tank. The trim pH adjustment will be used to minimize chemical use and ensure proper effluent quality. Continuous acid and caustic dosage will be applied, as required, at the trim pH adjustment location. A final pH adjustment will be located at the effluent discharge pumps and will be used to make any last pH adjustments in the event the level is outside the normal range for biological treatment.

Sulfuric acid will be used to lower the effluent pH. A caustic, sodium hydroxide (NaOH), will be used to raise the effluent pH. Sulfuric acid and caustic dosing will be carried out using six 0.8 kW, 23 L · min⁻¹ metering pumps (*i.e.*, three for each system): two for the

trim pH adjustment; two for the final pH adjustment; and two for standby (Figure 22). It is estimated that about $50 \text{ L} \cdot \text{day}^{-1}$ to $100 \text{ L} \cdot \text{day}^{-1}$ of sulfuric acid and about $3\,000 \text{ L} \cdot \text{day}^{-1}$ of NaOH (*i.e.*, 100 % concentration) will be used for pH control within the ETF. Both the sulfuric acid and caustic will be delivered by truck. It is expected that no more than one truck per month will be required for sulfuric acid delivery and no more than one truck per week for caustic delivery.

2.7.1.4.3 Indirect Air Coolers

Effluent produced during the Kraft pulping process can be relatively warm with a temperature ranging from $40 \text{ }^{\circ}\text{C}$ to $60 \text{ }^{\circ}\text{C}$. Those temperatures are too high for the microorganisms responsible for the biological treatment of the effluent to thrive. The optimum temperature for biological treatment is between $35 \text{ }^{\circ}\text{C}$ and $37 \text{ }^{\circ}\text{C}$. Therefore, when the effluent is outside of that range, it will be cooled before being directed to the biological treatment process.

Indirect cooling technology, in the form of an indirect air cooler, will be used to cool the effluent (Figure 21 and Figure 22). The technology is based on evaporative cooling. The warm effluent from the equalization tank will flow through tube bundles in a closed loop system (Figure 24). The warm tube bundles will be sprayed with water from above. As the spray water travels downward over the tube bundles, heat from the tube bundles will be released to the cascading water causing evaporation and a transfer of heat to the air stream. Coincident with the spraying of water over the tube bundles, 1.5 m diameter fans located at the top of the tower will draw air into the unit and across the tube bundles. The water that does not evaporate as it cascades downwards will be collected in a large basin at the bottom of the unit and will be reused as spray water. Depending on the water quality, the cooling water can be reused six to ten times. The spray systems are designed to provide $\sim 400 \text{ L} \cdot \text{min}^{-1} \cdot \text{m}^{-2}$. The saturated air stream flowing through the tower will be forced to make a 180° turn before exhausting out the top of the tower. The reduction in air velocity while making that turn will remove free water droplets that will also be returned to the unit's basin for reuse. The air will then be discharged out the top of the tower through the fan stacks at a high velocity, which will minimize recirculation to the unit's intake. Each indirect air cooler fan emits sound at < 70 A-weighted decibels (dBA) at 1 m.

The indirect air coolers proposed for this Project will be custom designed to include fin coolers ahead of the high-velocity exhaust fans. The fin coolers will lower the temperature of the moist air to allow any additional water droplets to condense and fall out of the air stream before being exhausted to the atmosphere. Equipping the indirect air coolers with fin coolers will eliminate the risk of bacteria from being contained in the exhausted air. An oxidant will also be added to the feed water of these indirect air coolers. Under normal operations, the addition of the oxidant will inhibit bacterial growth in the water spray water collection basin.

Additional information on examples of indirect air coolers is provided in product brochures included in Appendix V.

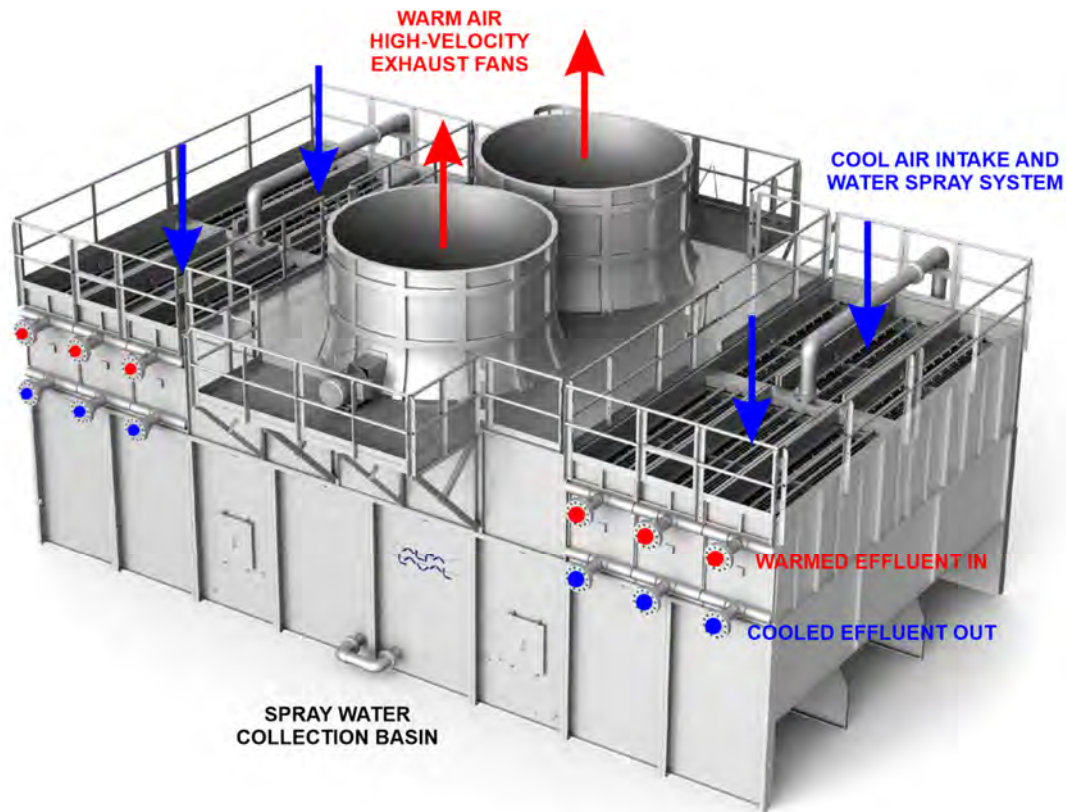

Figure 24. Schematic showing an example of an indirect air cooler system proposed for the environmental treatment facility at the Reversing Falls Mill in Saint John, New Brunswick.

2.7.1.4.4 Diversion Tank

As is common practice in modern industrial ETFs, a separate diversion tank will be included to allow the operators to divert effluent in the event of an extreme upset event at the Mill such as when the process flows from the Mill are outside the tolerances of the ETF to handle (*i.e.*, the tank will provide for spill diversion and surge protection). The 13 630 m³ concrete (*n.b.*, depending on market conditions, the tank may be constructed from stainless steel) tank (*i.e.*, 61.6 m diameter and 4.6 m tall; Figure 21) will allow an extra layer of protection to the system to ensure environmental compliance. Assuming both effluent streams (*i.e.*, process and bleachery) are diverted simultaneously, the hydraulic retention time of the diversion tank will be three to four hours based on average effluent flow.

Under normal operating conditions, the diversion tank will be kept clean and empty so that it has the capacity to accommodate any system upsets. The tank will have a sloped floor with a low point sump to allow small continuous flows to be pumped out without filling the entire tank.

The ETF is being designed in such a manner that effluent can be routed to the diversion tank before every main step of the treatment process and prior to being discharged at the MMO (Figure 22). This will provide maximum reliability in the instance of a malfunction of a specific process. Any effluent accumulated in the diversion tank will be reintroduced via

a duplex pumping system to the beginning of the treatment chain. The two 93 kW, 1 800 RPM, 5 680 L · min⁻¹ centrifugal pumps, which will be controlled using variable frequency drives, will either direct the effluent upstream of the screening process or the EQ tank depending on the effluent characteristics. The pumps will have the capacity, when operating simultaneously, to completely drawdown the diversion tank over a 20 hour period; however, the flowrate will be adjusted based on effluent quality to prevent shock loadings to the biological treatment process. When effluent is present in the diversion tank, four 11 kW, 1 200 RPM mixers will operate to ensure proper mixing and that no quiet zones develop. Whenever the ETF is capable of reintegrating the effluent into treatment, the flow will be directed either ahead of the pumping and screening process or the EQ tank.

A truck unloading pad, a sump, and two 7.5 kW, 1 800 RPM, 760 L · min⁻¹ sump pumps will be incorporated into the diversion tank to allow batch processing of effluent collected within 34 070 L capacity industrial vacuum trucks.

2.7.1.5 Biological Treatment

The organic matter contained in the effluent will be broken down using an aerobic biological treatment process. During that process, oxygen will be continuously mixed in to the effluent. The microbes within the system will digest the organic matter contained in the effluent and convert that organic matter into new biomass and carbon dioxide. The sections below describe the effluent biological treatment process.

2.7.1.5.1 Moving Bed Biofilm Reactor (MBBR)

The MBBR technology was briefly described in Section 2.6.3.3. Two 8 250 m³ (*i.e.*, 35.4 m diameter and 9.3 m tall) AnoxKaldnes™ MBBRs installed in series and equipped with K5 carrier media comprised of durable high density polypropylene will be used to treat the effluent (Figure 21 and Figure 22). Preliminary operational performance of the MBBRs is provided in Table 10.

The AnoxKaldnes™ technology has been employed in over 125 pulp and paper mills throughout the world since about 1993. The 1 700 m³ MBBR currently used by IPP since 2000 as part of their pollution prevention strategy described in Section 2.2.1 is this technology.

Aeration and mixing will be provided to the MBBRs using six (*i.e.*, five duty and one standby) 250 kW turbo air blowers installed in the main ETF building. Each blower has an average and peak design flow of 28 000 Nm³ · hr⁻¹ and 38 000 Nm³ · hr⁻¹, respectively. The units operate at 75 dBA. The air will be distributed through a coarse bubble diffuser system located at the bottom of each MBBR. Dissolved oxygen probes will be installed within each MBBR to ensure the proper amount of air is supplied from the blowers.

The K5 carrier media will be kept in motion by the aeration and mixing system described above. The carrier media will be held in the treatment tanks by sieves that are placed over the outlet. Those sieves allow the treated water to pass to downstream units for further processing. The sieves are not only designed to retain the carrier media, but also to avoid blockages.

Table 10. Preliminary operational performance of the two AnoxKaldnes™ moving bed biofilm reactors proposed for the environmental treatment facility at the Reversing Falls Mill in Saint John, New Brunswick.

Parameter	Average	Maximum
Flow (m ³ · day ⁻¹)	70 000	91 000
Inflow COD _i (kg · day ⁻¹)	68 527	137 055
Hydraulic retention time (min)	198	126
Media loading (%)	50	50
COD _s Load (kg · m ⁻³)	2.99	8.31

2.7.1.5.2 Nutrient Adjustment

To ensure proper biological treatment, the microorganisms will require nutrients, primarily N and P. Nitrogen is an essential nutrient for the formation of amino acids and several cellular compounds. Phosphorous is also an essential nutrient for the transfer of intracellular energy and the synthesis of several cellular compounds. Pulp and paper effluent is known to be deficient in nitrogen and phosphorous, so to account for this, those nutrients will be added to the effluent.

Total Organic Carbon (TOC), ammonia (NH₃) and ammonium (NH₄), and total phosphorous analyzers will be installed on the discharge lines of each MBBR. Measurements made from those analyzers will allow proper levels of nutrients to be added to the effluent. During detailed design, IPP's engineering team will select the best instruments and sensors for use within the ETF. They will also identify where those instruments and sensors should be located to adequately monitor treatment performance.

Typical nutrient addition will be based upon a BOD₅ : N : P ratio of 100 : 5 : 1. Mill-specific values will be established once the ETF is in operation. Regular monitoring of the effluent will provide the operators with the necessary data to adjust the ratios and ensure effective nutrient management. The monitoring will be done through a combination of inline sensors and instruments and using skilled technicians testing samples within the onsite laboratory.

2.7.1.5.2.1 Nitrogen

Nitrogen in the form of a 40 % W / W urea (CH₄N₂O) solution (*i.e.*, 205 200 mg N · L⁻¹) will be used. A urea solution will be used instead of a crystal based solid because no preparation is required for the solution and minimal equipment will be required to add it to the effluent. Table 11 provides an estimate of nitrogen required based on the ETF design flow and loads (*e.g.*, Table 7). The estimates are based on the worst-case scenario, which assumes that the BOD is entirely removed and no nitrogen is initially present in the effluent.

The urea will be stored in a 67 760 L (*i.e.*, 4.0 m diameter by 5.5 m tall) tank housed in the ETF process building (Figure 21). The urea will be delivered to the ETF using 23 970 L semitrailers (*n.b.*, spring delivery volume would be limited to 19 176 L to account for road weight restrictions) and it is anticipated that deliveries could range from one semitrailer

every 1.8 days (*i.e.*, maximum long-term during the spring) to 5.7 days (*i.e.*, average short-term).

Urea dosage will be performed proportionally on the BOD load, based on the TOC online measurement, and a conversion factor to BOD. The dosage will be carried out upstream of each MBBR using three 0.8 kW, 23 L · min⁻¹ metering pumps (*i.e.*, one duty pump for each MBBR plus one standby). The equipment will be operated in a containment area that will allow any spills or failures to be routed to the diversion tank.

Table 11. Estimates for nitrogen addition to the effluent in the form of a 40 % W / W urea solution at the Reversing Falls Mill in Saint John, New Brunswick.

Parameter	Average	Maximum
BOD ₅ to degrade (kg · day ⁻¹)	30 666	44 250
Theoretical N required (kg · day ⁻¹)	1 533	2 213
Targeted N dosage (kg · day ⁻¹)	1 549	2 235
Urea dosage (L · day ⁻¹)	7 547	10 890

2.7.1.5.2.2 Phosphorous

Phosphorous in the form of phosphoric acid (H₃PO₄) solution at 75 % W / W will be used (*i.e.*, 364 567 mg P · L⁻¹). Table 12 provides an estimate of phosphorous required based on the ETF design flow and loads (*e.g.*, Table 7). The estimates are based on the worst-case scenario, which assumes that the BOD is entirely removed and no phosphorous is initially present in the effluent.

The phosphoric acid will be stored in a 36 720 L (*i.e.*, 3.2 m diameter by 4.6 m tall) tank housed in the ETF process building (Figure 21). The phosphoric acid will be delivered using 17 148 L semitrailers (*n.b.*, spring delivery volume would be limited to 13 959 L to account for road weight restrictions) and it is anticipated that deliveries could range from one semitrailer every 11.4 days (*i.e.*, maximum long-term during the spring) to 37.2 days (*i.e.*, average short-term).

Table 12. Estimates for phosphorous addition to the effluent in the form of a 75 % W / W phosphoric acid solution at the Reversing Falls Mill in Saint John, New Brunswick.

Parameter	Average	Maximum
BOD ₅ to degrade (kg · day ⁻¹)	30 666	44 250
Theoretical P required (kg · day ⁻¹)	307	443
Targeted N dosage (kg · day ⁻¹)	309	447
Phosphoric acid dosage (L · day ⁻¹)	850	1 226

Phosphoric acid dosage will be performed proportionally on the BOD load, based on the TOC online measurement, and a conversion factor to BOD. The dosage will be carried out upstream of each MBBR using three 0.8 kW, 23 L · min⁻¹ metering pumps (*i.e.*, one duty pump for each MBBR plus one standby). The equipment will be operated in a containment area that will allow any spills or failures to be routed to the diversion tank.

2.7.1.6 Secondary Clarification

The objective of the secondary clarification process is to remove TSS that is fed to and produced in the MBBRs. The flocculated biomass settles out leaving a final effluent virtually free of solids.

2.7.1.6.1 Dissolved Air Flotation (DAF)

IPP's engineering team considered all technologies for solids separation when designing the ETF. The most effective clarification technology was selected for secondary clarification. The MBBRs generate solids that are more effectively separated by flotation versus gravity settling. Therefore, separation by flotation (*i.e.*, from the liquid surface) was selected for secondary clarification. This is the final settling method used at the two Mill's visited that employ MBBRs (*i.e.*, refer to Section 2.6.3.7.1).

Dissolved Air Flotation (DAF) technology is a secondary clarification process that removes suspended matter, such as solids. The solids removal is achieved by dissolving air into the effluent under pressure and then releasing the air at atmospheric pressure in a flotation tank basin (Figure 25). As the air is released, it forms micro bubbles that adhere to the suspended matter in the effluent, causing it to float to the surface where it can be removed by a skimming device. Solids that settle to the bottom is also removed. DAF technology has a high separation efficiency that results in a high solids content (*i.e.*, 2 % to 4 % by weight).

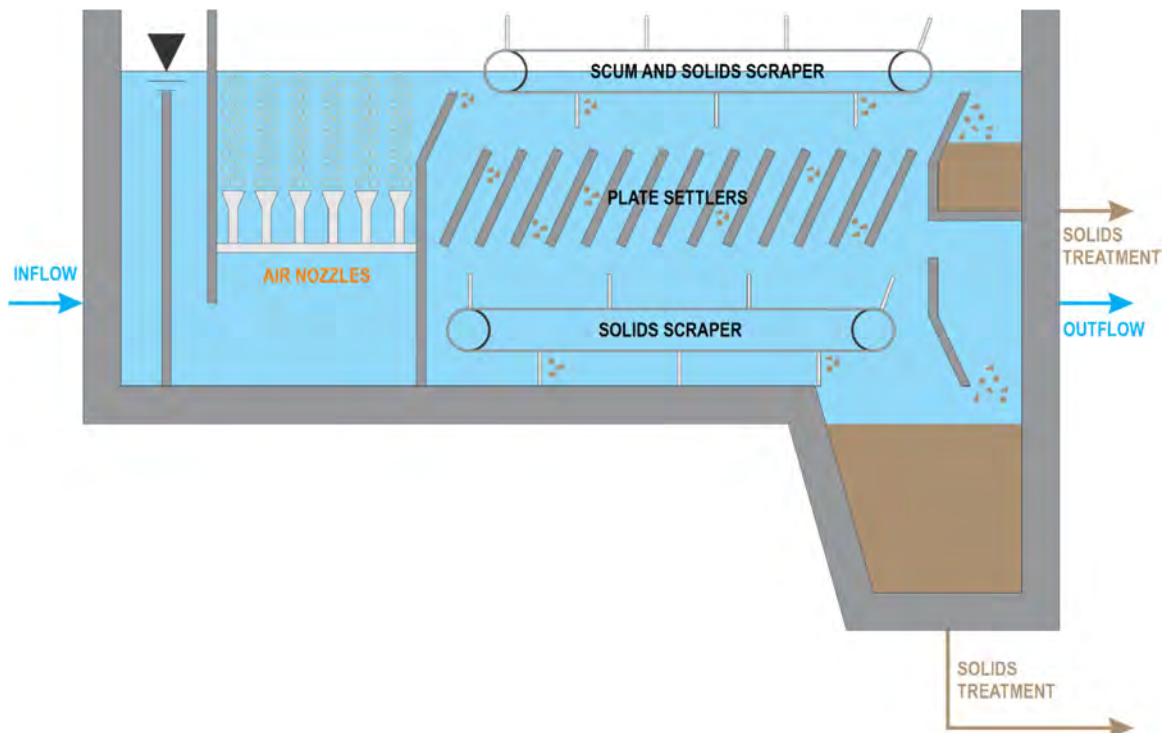

Figure 25. Cross-section of a typical dissolved air flotation unit.

After going through the two MBBRs, the effluent will be gravity fed to four DAF units (*i.e.*, three duty and one standby) housed in the ETF process building (Figure 21 and Figure 22). Four DAF units operated in parallel will ensure effluent treatment at the maximum

flow and load conditions listed in Table 7 and will allow operational and maintenance flexibility. The proposed technology has an expected average TSS removal rate of 90 %. Each DAF unit has an effluent design flow rate of $972 \text{ m}^3 \cdot \text{hr}^{-1}$, a whitewater flow rate of $155 \text{ m}^3 \cdot \text{hr}^{-1}$, and a flotation velocity of $28 \text{ m} \cdot \text{hr}^{-1}$. Each DAF will be equipped with three 22.4 kW whitewater pumps and one 0.8 kW solids scraper. Solids from the DAF units will be gravity fed to the secondary solids tank.

To provide adequate coagulation and flocculation, the effluent will pass through a flocculation tank prior to entering the DAF units. Each DAF unit will have its own reaction tank (Figure 22). Sizing of the mixers for the reaction tanks has not yet been determined.

2.7.1.6.1.1 Polymer Addition

Addition of polymer may be required to increase the performance of the DAF units. For example, when the feed TSS levels are elevated, polymers will be added by the operators. A dry polymer makeup system will be installed within the ETF process building (Figure 21). The polymer dosage will be flow controlled. Each DAF unit will have its own 1.1 kW, 1 750 RPM, $38 \text{ L} \cdot \text{min}^{-1}$ progress cavity metering pump (Figure 22). The type of polymer will be determined during detailed design; however, it is estimated that the dosage could range from $0 \text{ mg} \cdot \text{L}^{-1}$ to $5 \text{ mg} \cdot \text{L}^{-1}$ (*i.e.*, $16 \text{ kg} \cdot \text{hr}^{-1}$ of dry polymer).

2.7.1.7 Solids Treatment

The effluent treatment process will generate solids. To properly dispose of the solids economically and in an environmentally sound manner, it will be dewatered. The dryness of the solids obtained from the primary clarifier and the DAFs will typically range between 0.5 % and 4 % by weight. The solids treatment chain will consist of a primary solids tank that collects solids from the primary clarifier and a secondary solids tank that collects solids from the DAFs (Figure 22). Prior to being pumped and dewatered, the two streams will be combined in a mixing tank.

The sections below describe the solids treatment process in more detail.

2.7.1.7.1 Solids Production

The expected daily solids volumes from primary and secondary clarification and the anticipated dryness of the solids are provided in Table 13.

Table 13. Expected daily solids volumes and dryness from primary and secondary clarification for the environmental treatment facility at the Reversing Falls Mill in Saint John, New Brunswick.

	Parameter	Average	Daily Max
Primary solids	Dry mass (kg · day ⁻¹)	3 035	13 125
	Dryness (%)	2.5	2.5
	Volume (m ³ · day ⁻¹)	121	525
Secondary solids	Dry mass (kg · day ⁻¹)	12 474	29 992
	Dryness (%)	2.5	2.5
	Volume (m ³ · day ⁻¹)	499	1 200
Total solids	Dry mass (kg · day ⁻¹)	15 509	43 117
	Dryness (%)	2.5	2.5
	Volume (m ³ · day ⁻¹)	620	1 725
	Mass ratio (1° : 2°)	20 : 80	30 : 70

2.7.1.7.2 Solids Tanks

Several solids tanks will be required for holding and processing the solids generated during the treatment process. The solids tanks will be housed on the ground floor of the ETF process building (Figure 21).

2.7.1.7.2.1 Primary Solids Tank

With respect to the long-term average solids production conditions (*i.e.*, Table 13), the 48 075 L (*i.e.*, 3.1 m diameter by 4.3 m tall) primary solids tank will have a retention time of six hours. The stainless steel tank will have an air header at the bottom to ensure constant mixing. Mixing the primary solids will minimize settling at the bottom of the tank. The air will be supplied by a shared air blower (Figure 22). A single 3.7 kW, 1 200 RPM, 140 L · min⁻¹, pump will transfer the primary solids to the solids blending tank on a ratio flow control basis with the secondary solids flow.

The blowers will be housed in a mechanical room of the ETF process building. That mechanical room will be insulated to help mitigate the sound emissions from the air blowers.

2.7.1.7.2.2 Secondary Solids Tank

The stainless steel secondary solids tank will have a retention time of eight hours based on the long-term average solids production conditions presented in Table 13. The 217 660 L (*i.e.*, 7.3 m diameter by 5.2 m tall) stainless steel tank will also be equipped with an air header at the bottom and supplied air by a shared blower to ensure constant mixing (Figure 22). A single 7.5 kW, 1 800 RPM, 530 L · min⁻¹ pump will transfer the secondary solids to the blending tank on a ratio flow control basis with the primary solids flow.

2.7.1.7.2.3 Solids Blending Tank

The primary and secondary solids will be combined in a 31 040 L (*i.e.*, 2.4 m diameter by 4.6 m tall) stainless steel tank (Figure 22). The blending tank will have a 20 minute retention time at maximum future solids production conditions and a 30 minute retention time based on the long-term average solids production conditions (*i.e.*, Table 13). To ensure thorough mixing of the primary and secondary solids, an agitator will be installed within the tank. The level in the tank will be controlled by the ratio flow controllers of the primary and secondary solids tanks. Two 11.2 kW, 1 800 RPM, 340 L · min⁻¹ pumps will independently direct the blended solids to the dewatering system.

2.7.1.7.2.4 Centrate Tank

The centrate tank will collect streams from the dewatering system (Figure 22). The 9 460 L (*i.e.*, 1.8 m diameter by 3.7 m tall) stainless steel tank will have a minimum retention time of 30 minutes. The centrate will be constantly mixed within the tank using a bottom air header supplied air by a shared blower. Two (*i.e.*, one duty and one standby) 5.6 kW, 1 800 RPM, 475 L · min⁻¹ centrifugal pumps will transfer the centrate to the inlet of the effluent screen described in Section 2.7.1.3.1. The level in the centrate tank will be controlled by a variable frequency drive to the pumps.

2.7.1.7.3 Dewatering System

Two technologies are currently being considered for dewatering the solids, which are described in the sections below. Both technologies have been piloted and show good potential for dewatering. Both technologies typically yield an average cake dryness of between 18 % and 22 % with a peak up to 24 % of dry solids under optimum conditions.

2.7.1.7.3.1 Centrifuges

Three centrifuges (*i.e.*, two duty and one standby) may be used to dewater the solids. Each centrifuge will have a design flow of 20 m³ · hr⁻¹ and a solids design load of 1 000 kg · day⁻¹. Solids capture efficiency is estimated to be > 95 % and the expected dewatered solids dryness ranges between 16 % and 20 %. Process wash water will be applied at a rate of 400 L · min⁻¹ and the air vent will yield 200 m³ · hr⁻¹. Each centrifuge will be equipped with a 55.9 kW main motor and a 14.9 kW secondary motor.

2.7.1.7.3.2 Presses

Rotary presses may also be used to dewater the solids. If selected, the number of presses (*i.e.*, duty and standby) will be determined during detailed design. The total design load for the operational presses will be up to 2 000 kg · day⁻¹.

2.7.1.7.3.3 Polymer Addition

The addition of polymer is recommended to ensure performance of the dewatering system. Because the daily dosage is expected to be significant, a dry polymer makeup system will be installed within the ETF process building (Figure 21). The polymer will be injected into the blended solids piping system upstream of the dewatering system. The polymer dosage will be based on a multivariable model predictive control algorithm using the following measurements:

- total solids feed to the dewatering system as a weight percentage;
- total solids dewatering system discharge cake as a weight percentage; and
- total solids in the centrate as $\text{mg} \cdot \text{L}^{-1}$.

The type of polymer will be determined during detailed design; however, it is estimated that the dosage could be on average $16 \text{ kg} \cdot \text{tonne}^{-1}$ (*i.e.*, $16 \text{ kg} \cdot \text{hr}^{-1}$ of dry polymer) to a maximum of $20 \text{ kg} \cdot \text{tonne}^{-1}$ (*i.e.*, $24 \text{ kg} \cdot \text{hr}^{-1}$ of dry polymer). The polymer will be injected using three (*i.e.*, two duty and one standby) 2.2 kW, 1 800 RPM, $115 \text{ L} \cdot \text{min}^{-1}$ progressive cavity pumps (Figure 22).

2.7.1.7.4 Solids Disposal

The recovered and dewatered solids will be so pure that it will be almost entirely fibre and biosolids. That material will either be sent to the onsite biomass boiler or an offsite compost facility. If the solids are burned within the onsite biomass boiler, greenhouse gas emissions associated with purchased electricity emissions to operate the ETF will be offset. The small amount of ash from biomass burning can be land spread as the Proponent already has labels in place for that process.

2.7.1.8 Process Building

The 62.8 m long, 31.5 m wide, by 19.5 m tall ETF process building will be a new build. It will be a steel-framed structure with steel siding founded on an engineered concrete slab. A portion of the concrete slab, not placed atop bedrock, will be structurally supported by steel H-piles with a 30.5 cm flange width. It is anticipated that between 120 to 150 piles up to 5 m long will be required (*n.b.*, about 20 to 30 of those piles will be required for supporting the adjacent EQ tank). Each pile will be driven to bedrock. About half of the building will have three floors while the other half will have only two floors in order to accommodate the DAF units.

2.7.1.8.1 Utilities and Ancillary Equipment

2.7.1.8.1.1 Warm Raw Water

The process water used within the ETF will be warm raw water from the Mill supplied via a 200 mm PolyVinylChloride (PVC) line. A single 75.6 kW, 1 800 RPM, $3\,785 \text{ L} \cdot \text{min}^{-1}$ booster pump located in the ETF process building will supply the process water requirements (Figure 22). The warm raw water will be temperature controlled at the Mill to ensure it meets the polymer make-up system specifications.

2.7.1.8.1.2 Seal Water

Seal water will be supplied from the warm raw water header within the ETF process building. A pressure reducing valve with a duplex strainer will ensure proper seal water quality. Sodium hypochlorite (NaOCl) will be added to maintain a small chloride residual in the seal water to prevent biological growth.

2.7.1.8.1.3 Potable Water

Potable water will be supplied by the City of Saint John. A 9 464 L (*i.e.*, 1.8 m diameter by 3.7 m tall) tank will store potable water for use in the laboratory, lavatories, kitchen, and safety showers (*n.b.*, the safety showers will use tempered water). The water will be distributed using two 7.5 kW, 3600 RPM, 379 L · min⁻¹ pumps.

2.7.1.8.1.4 Hot Water

An inline heater will be used to provide hot wash-up water around the chemical storage and pumping areas. The water for this process will be supplied from the Mill.

2.7.1.8.1.5 Sanitary Wastewater Holding Tank

A sanitary wastewater holding tank will be used to collect greywaters and blackwaters generated in the laboratory, lavatories, and kitchen. The tank will be emptied on a batch-wise schedule, which is anticipated to be once every two weeks based on the limited occupancy of the building.

2.7.1.8.1.6 Compressed Air

All compressed air required for use at the ETF will be supplied by two (*i.e.*, one duty and one standby) 18.6 kW, 2.7 m³ · min⁻¹ pumps. The system will include air drying and a 454 L compressed air storage tank.

2.7.1.8.1.7 Power and Back-Up Power

Power for the Mill is purchased through NB Power. It is supplied via an NB Power transmission line that connects with the Mill. Existing power distribution to the Mill is suitable for supplying the 575 volt three phase power requirements of the ETF.

The Mill operates 24 / 7 / 365 and requires an uninterrupted and continuous power supply. There are automatic back-up power sources at the Mill that operate all necessary infrastructure in the event of a power failure. Project components will be connected to those automatic back-up power sources (*i.e.*, diesel power generators) to ensure they continue to operate seamlessly during a power failure.

2.7.1.8.1.8 Lighting

For employee safety and for process and security monitoring, new exterior lighting will be installed on the exterior of the ETF. The light fixtures will be installed every 9 m to 12 m along the exterior approximately 4.6 m above grade. Those luminaries will be Light-Emitting Diodes (LEDs) that shine downwards (*i.e.*, Streetworks OVF or equivalent). Light fixtures will also be installed along the elevated walkway and the tanks. Those fixtures will be vertically adjustable LEDs (*i.e.*, RAB FL8 or equivalent) directed to shine downwards at a 45 ° angle. All new exterior luminaries will be switched with lighting sensors such that they turn on in low-light conditions and turn off during optimum daylight conditions. Standard practice will be for them to operate continuously during low-light conditions.

The design and selection of exterior lighting for this Project balances employee safety criteria with requirements to minimize the effect on the environment and neighbours. Awareness of light pollution (*i.e.*, sky glow), light trespass (*i.e.*, spill light), and veiling luminance (*i.e.*, glare) are all being considered in the lighting design. The lighting design will be such that light trespass will be minimized. As a result, occupants of neighbouring spaces will be minimally affected because of the lighting system's ability to contain light within its intended area. To minimize light trespass, luminaires will be tilted or aimed away from neighbouring spaces as noted above. Luminaires will also be selected to minimize glare and up-lighting, which can affect avians.

2.7.1.8.1.9 Fire Prevention and Life Safety Equipment

Fire water will be supplied to the ETF via a 200 mm PVC pipe extended from the Mill. New fire prevention equipment will be constructed in accordance with the National Fire Code and the National Fire Protection Association (NFPA) requirements (*i.e.*, NFPA 820 Standard for Fire Protection in Wastewater Treatment and Collection Facilities). Automatic sprinkler systems will be included throughout the ETF process areas to provide the necessary level of fire protection. Portable fire extinguishers will also be installed in specific areas of the ETF process building.

Rescue hooks and life buoy rings will be placed in appropriate areas at the ETF to provide means of rescue in the event someone falls into a tank. All elevated walkways and catwalks will be designed with non-slip surfaces and equipped with safety rails of suitable heights.

Air quality monitors will be installed to monitor for hydrogen sulfide and chlorine dioxide. If levels exceed a specific threshold, alarms will sound to warn operators and occupants.

2.7.1.8.1.10 Design Standards

The ETF will be designed, constructed, operated, maintained, and abandoned using accepted standards and methods that are in accordance to the applicable *Acts*, permits, authorizations, regulations, and guidelines. Those standards and methods will reflect current legislation (*i.e.*, abandonment will reflect those standards and methods at some future date).

All materials, equipment, and installation labour supplied for this Project will be in accordance with all of the requirements governing New Brunswick jurisdictional codes. In particular, all work performed will conform to the most recent codes of the organizations listed in Table 14. All contractors working on the Project will possess the necessary permits, certifications, and / or licenses to undertake Project work. The primary codes of reference that contractors will focus on are also listed in Table 14.

Table 14. Jurisdictional organizations and contractor's codes of reference for the environmental treatment facility at the Reversing Falls Mill in Saint John, New Brunswick.

Acronym	Description	Project Applicable Component(s)
<u>PROJECT JURISDICTIONAL ORGANIZATIONS</u>		
ANSI	American National Standards Institute	
ASME	American Society of Mechanical Engineers	
ASTM	American Society for Testing and Materials	
CGSB	Canadian Government Standards Board	

Acronym	Description	Project Applicable Component(s)
CSA	Canadian Standards Association	
FM	Factory Mutual	
MSS	Manufacturers Standardization Society	
TEMA	Tubular Exchange Manufacturers' Association	
TIAC	Thermal Insulation Association of Canada	
ULC	Underwriter Laboratory of Canada	
<i>PROJECT CONTRACTOR'S CODES OF REFERENCE*</i>		
ABMA	American Bearing Manufacturers' Association	Bearings
AGMA	American Gear Manufacturers' Association	Speed reducers
ANSI	American National Standards Institute	Piping and electrical equipment
API	American Petroleum Institute	Tanks
ASHRAE	American Society of Heating, Refrigeration, and Air Conditioning Engineers	Heating, ventilation, and air conditioning equipment
ASME	American Society of Mechanical Engineers	Boilers and pressure vessels
ASTM	American Society for Testing Materials	Materials specifications
AWWA	American Water Works Association	Underground piping and potable water
CEC	Canadian Electrical Code	All electrical equipment
CEMA	Conveyor Equipment Manufacturers' Association	Conveyors
CSA	Canadian Standards Association	Electrical equipment, concrete, and steel structures
CWB	Canadian Welding Bureau	Welding
EEMAC	Electrical and Electronic Manufacturers' Association of Canada	Electrical equipment
ICEA	Insulated Cable Engineers Association	Electrical cables
IEC	International Electric Commission	Electric motors and electric equipment
IEEE	Institute of Electrical and Electronic Engineers	Electrical equipment
ISA	Instrument Society of America	Instrumentation
NBC	National Building Code of Canada (2010)	Buildings and structures
NEMA	National Electrical Manufacturers' Association	Electrical enclosures
NFPA	National Fire Protection Association	Fire protection
OSHA	Occupational Safety and Health Administration	Safety regulations for NB
SCAN	Scandinavian Pulp, Paper, and Board Testing Committee	
SSPC	Structural Steel Painting Council	Painting
TAPPI	Technical Association of the Pulp and Paper Industry	Equipment
TEMA	Tubular Exchange Manufacturers' Association	Tubular exchangers
TIMA	Thermal Insulation Manufacturing Association	Insulation

NOTES:

*regarding Country of Origin, codes and standards are to be applicable to the manufacture of equipment / materials

2.7.1.9 Landscaped Berm

A landscaped berm (Figure 21) in three sections (Figure 26) will be established along a largely unoccupied stretch of Milford Road. The berm will mask the view of infrastructure associated with the ETF from Milford Road. The several meter high and wide berm will be constructed of dirt, gravel, and rock that is appropriately sized to address offsite visual and audible impacts. Grass will be planted along the side slopes and top. Trees will be planted atop the berm to further mitigated views of the ETF.



Figure 26. General location for placement of the landscaped berm in three sections to help mask the view of the environmental treatment facility proposed for the Reversing Falls Mill in Saint John, New Brunswick.

2.7.1.10 Environmental Treatment Facility Summary

As part of an on-going, long-term, multi-phase upgrade program to maintain the Mill's global competitiveness, IPP is proposing to install new best-available technology to enhance the Mill's overall environmental performance and build upon the existing pollution prevention strategy equipment at the Mill. Through this Project, IPP will construct and operate an onsite ETF. MBBR treatment technology is being considered because it will meet the existing and any future changes to the federal pulp and paper effluent discharge limits including TSS and BOD and potential discharge limits related to toxicity, pH, N, P, temperature, and COD. Through the current pollution prevention strategy, IPP has experience at the Mill operating an MBBR.

IPP's engineering team has integrated several best-in-class technologies within the ETF design to yield additional environmental benefits. Those best-in-class technologies are summarized in Figure 27. This Project will place IPP among the global leaders in effluent treatment performance.

ENVIRONMENTAL TREATMENT FACILITY BEST-IN-CLASS TECHNOLOGIES FOR ADDITIONAL ENVIRONMENTAL BENEFITS

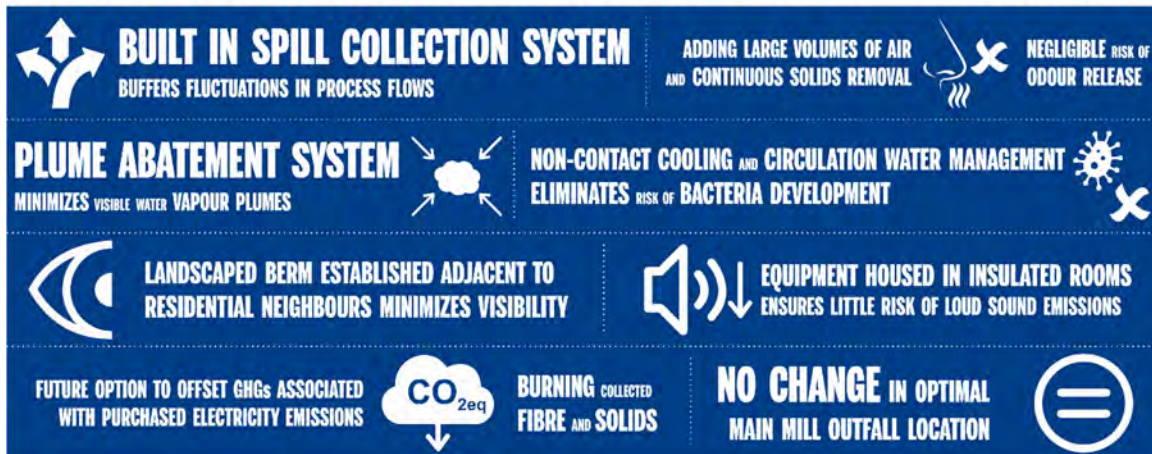

Figure 27. Summary of the best-in-class technologies to yield additional environmental benefits for the environmental treatment facility proposed for the Reversing Falls Mill in Saint John, New Brunswick.

2.7.2 Water Use Reduction

The goal for water use reduction is to collect approximately 47 500 L · min⁻¹ of fresh non-contact cooling water from various sections of the Mill (Figure 28). That fresh non-contact cooling water will then be reused as process water. Currently the fresh non-contact cooling water is discharged to the Saint John River. This Project will ultimately reduce the Mill's freshwater usage by eliminating the once-through freshwater cooling system and simultaneously reduce the Mill's effluent.

There is limited technology available to cool process water. Water is either cooled using evaporative cooling towers or by once through cooling (*i.e.*, indirect cooling). IPP's project team completed an initial review of evaporative cooling towers; however, they were quickly discarded because they would consume far more energy than indirect cooling and the footprint would be significantly larger.

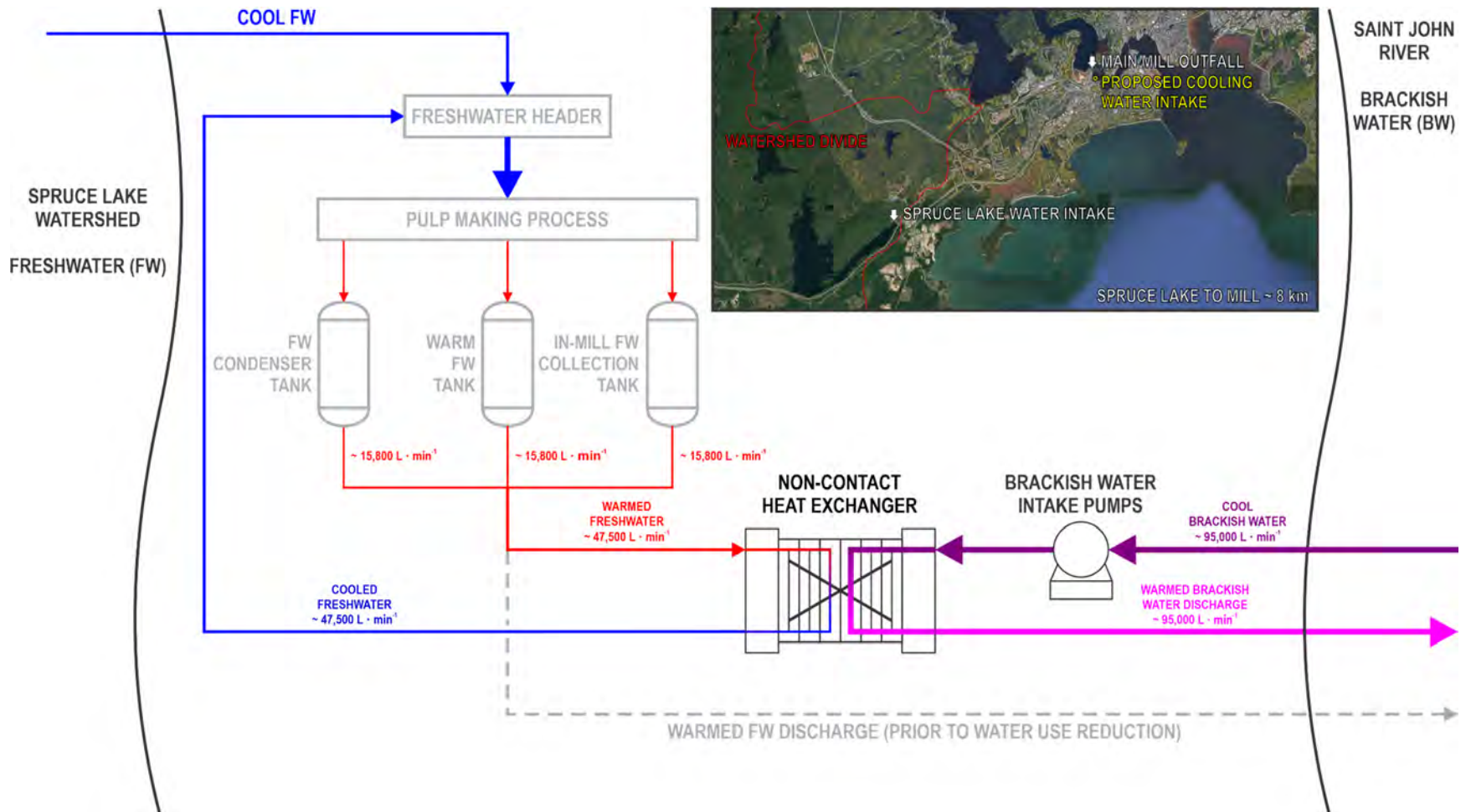

Figure 28. Conceptual flow diagram proposed for water use reduction at the Reversing Falls Mill in Saint John, New Brunswick. Equipment shown with black lines is proposed while that shown in thick grey is existing. The aerial photograph inset shows the location of the Spruce Lake Watershed to the Mill.

2.7.2.1 Cool Water Intake

Brackish water from the Saint John River will be drawn in to the Mill through two high-capacity, low-velocity (*i.e.*, $\leq 0.15 \text{ m} \cdot \text{s}^{-1}$) passive intake screens located about 1.7 m above the river bottom at Reversing Falls (Figure 30). The intake will extend about 22.1 m out in to the river at an elevation of - 7.8 m (*n.b.*, high tide and low tide elevation are 4.6 m and - 4.6 m, respectively). The passive intake screen system is an open pipe design with a slot width ranging from 1 mm to 10 mm. An internal dual flow modifier is contained inside the screen system to moderate flow.

The two high-capacity, low-velocity passive intake screens (Figure 29) constructed of Super Duplex stainless steel (*i.e.*, austenitic-ferritic iron chromium nickel alloy with molybdenum addition) will be connected to a 7.6 m inside diameter concrete sump below a pumphouse via a 1.2 m diameter about 77 m long below water / below ground HDPE intake pipe. The intake pipe will be supported above the river bottom using steel H-piles with a 30.5 cm flange width. The piles will be driven in to the river bottom as shown in (Figure 30).



Figure 29. Photograph showing an example of a high-capacity, low-velocity intake screen.

The intake will be equipped with an air-back-wash system. That system will clean the passive intake screens by regularly releasing an appropriate volume of compressed air through the bottom of the screen over the course of 3 to 5 seconds. The air will burst through a series of nozzles displacing the water inside the screen and pushing it in the opposite direction of normal flow. The air burst will carry away impinged debris collected on the screen surface in to the water column so the screen can continue to function continuously and properly. The air-back-wash system will be connected to the Mill's distributed control system for automatic or manual control.

Additional information on the high-capacity, low-velocity intake screens is provided in product brochures included in Appendix V.

The cool water intake will be constructed via micro-tunnelling as opposed to an open cut or horizontal directional drilling. A remotely-operated, laser-guided, and steerable tunnel boring machine will dig / drill through the subsurface materials. During this process, the machine will be launched through an entry hole and pipes will be pushed behind the machine as it advances (Figure 31). The process is often called pipe jacking and it will be repeated until the tunnel boring machine reaches the reception shaft (*i.e.*, Saint John River). The pipe will be inserted into the tunnel using hydraulic rams. Two practices will be used to help push the pipe: 1) a slightly oversized tunnel (*i.e.*, about 12 mm larger diameter than the pipe) and 2) a pressurized lubricant (*i.e.*, bentonite slurry). The tunnel boring machine will be retrieved from the end of the borehole using divers and a crane.

The micro-tunnelling process will include a spoils vacuum extraction system. Removal of the spoils will be a closed loop system that cycles the spoils back through a slurry machine on the surface for spoils separation and disposal.

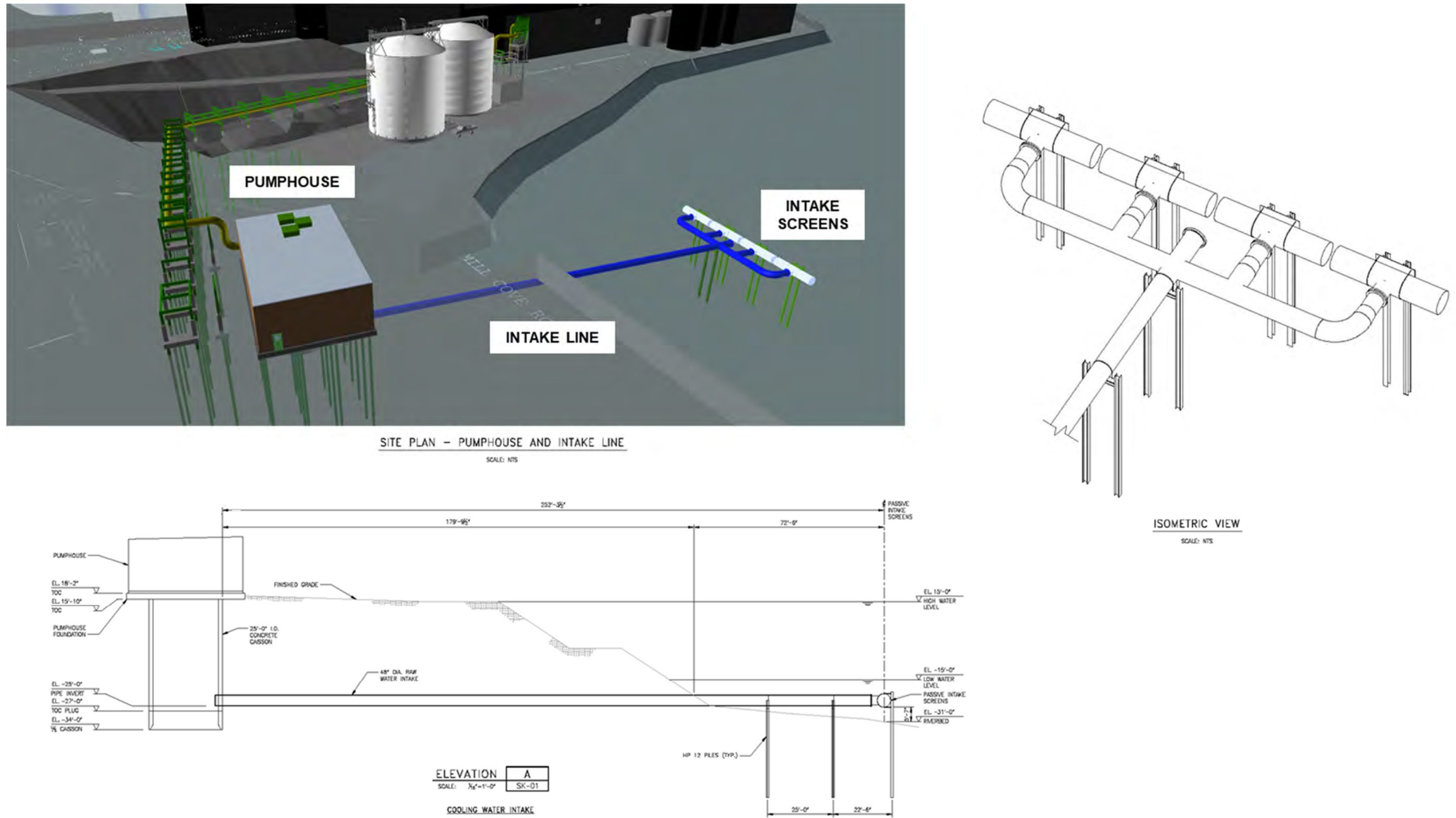

Figure 30. Proposed water intake and pumphouse for water use reduction at the Reversing Falls Mill in Saint John, New Brunswick.

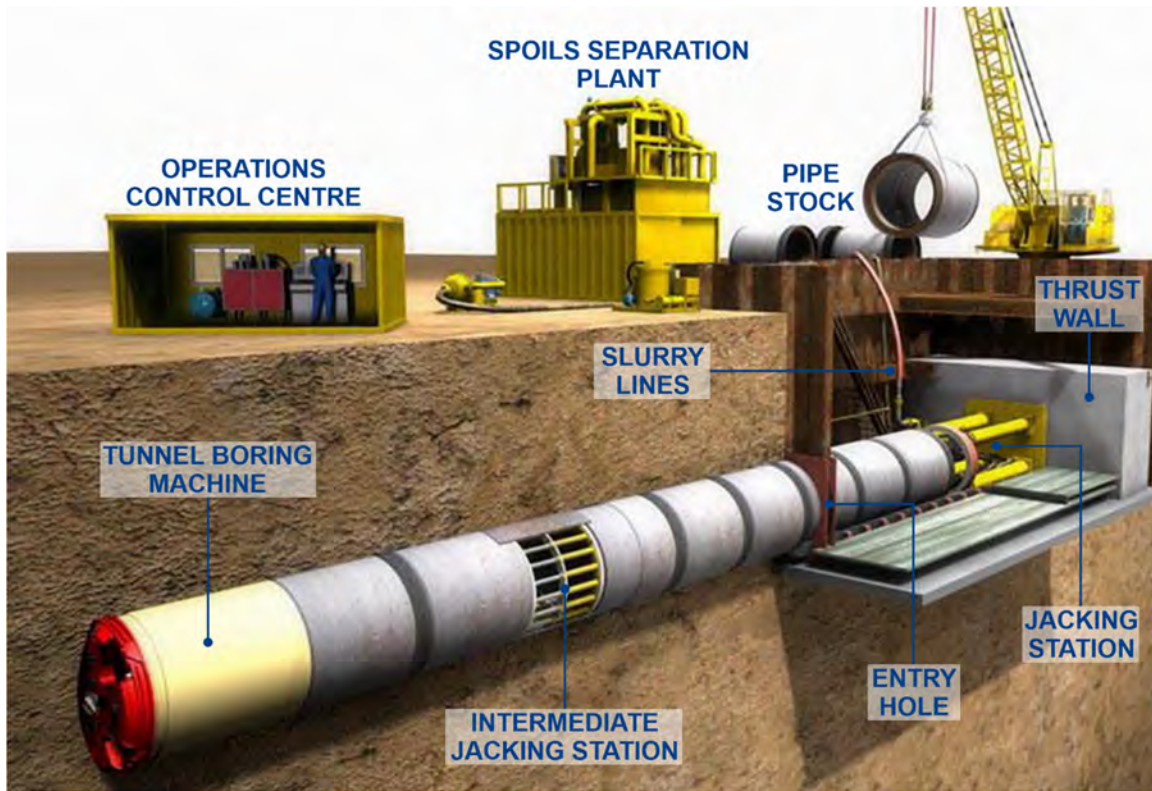

Figure 31. Conceptual model showing the micro-tunnelling process that will be used to install the cool water intake pipe proposed for water use reduction at the Reversing Falls Mill in Saint John, New Brunswick.

2.7.2.2 Pumphouse

The pumphouse will be a new 260 m² masonry block building founded on a concrete slab adjacent to the Saint John River about 29.5 m from the shoreline (Figure 20, Figure 30, and Figure 32). The slab will be structurally supported by steel H-piles with a 30.5 cm flange width. It is anticipated that 70 piles will be required. Each pile will be driven to bedrock. The 7.6 m inside diameter concrete sump will extend 15.9 m below ground (*n.b.*, the base elevation will be about -10.4 m). The following key infrastructure will be enclosed within the pumphouse:

- two operational, and a potential third stand-by, 170 350 L · min⁻¹ or 75 kW pumps;
- one 18.9 m³ compressed air tank to supply the air-back-wash system of the cool brackish water intake;
- two high-capacity rotary screw air compressors (*i.e.*, one for regular duty and one for stand-by use) to supply the compressed air tank; and
- an electrical room for housing the electrical equipment required to operate the systems.

The insulated walls of the building will help mitigate the sound emissions from the pumps and air compressors.

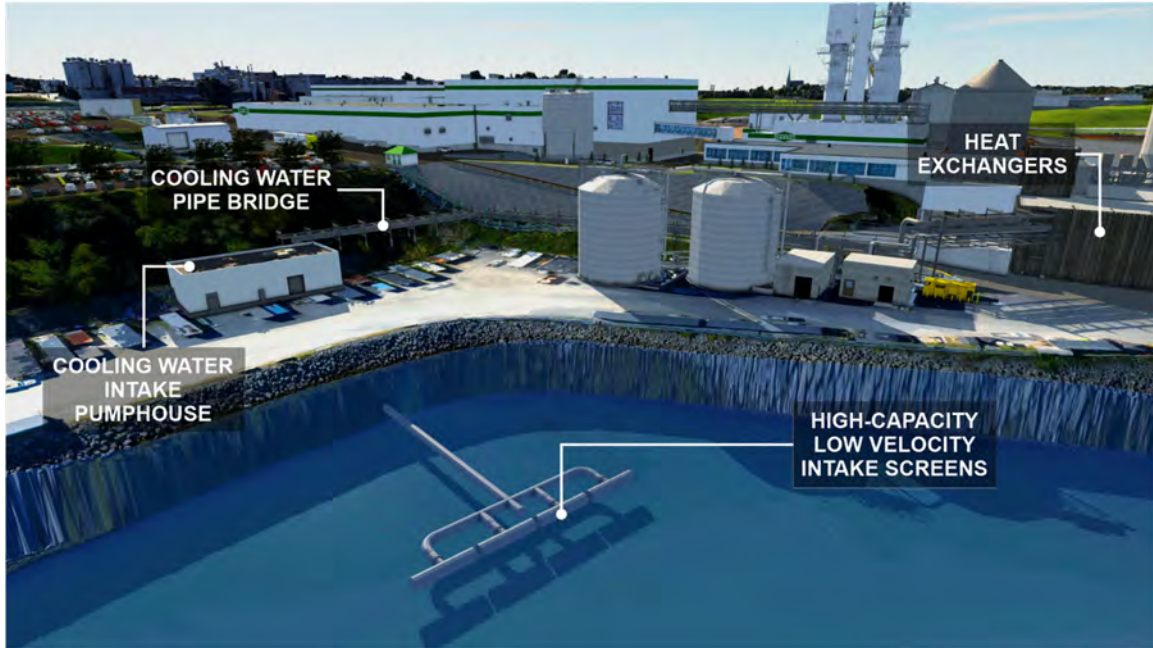

Figure 32. Three-dimensional model looking southwest showing the location of the pumphouse proposed for water use reduction at the Reversing Falls Mill in Saint John, New Brunswick.

2.7.2.3 Pipeline and Pipe Bridge

A 1.2 m diameter ~ 200 m long pipeline will extend from the pumphouse to the heat exchangers in the bale line area of the Mill (Figure 20 and Figure 32). The pipeline will be placed atop a steel pipe bridge that will be supported by several steel bents founded on spread concrete footings. Steel H-piles will be used to provide structural support to the concrete footings. The steel piles will have a flange width of 30.5 cm.

2.7.2.4 Heat Exchangers

The reclaimed warmed raw industrial freshwater from Spruce Lake will be cooled using five compact, gasketed, plate, and frame heat exchangers (Figure 33). The cooled raw industrial freshwater from Spruce Lake will then be reused within the Mill as process water while the non-contact warmed brackish water will be returned to the Saint John River (Figure 28). The highly thermally-efficient heat exchangers, which will operate in parallel, will be housed in the bale line area of the Mill. The anticipated thermal performance of the heat exchangers is presented in Table 15.

The heat exchangers will be stainless steel and should reduce the possibility of scale buildup. An extra heat exchanger has been built into the system design for redundancy. Should a heat exchanger develop scale and its performance is affected, it can be taken offline for descaling.

Additional information on the potential heat exchangers is provided in product brochures included in Appendix V.

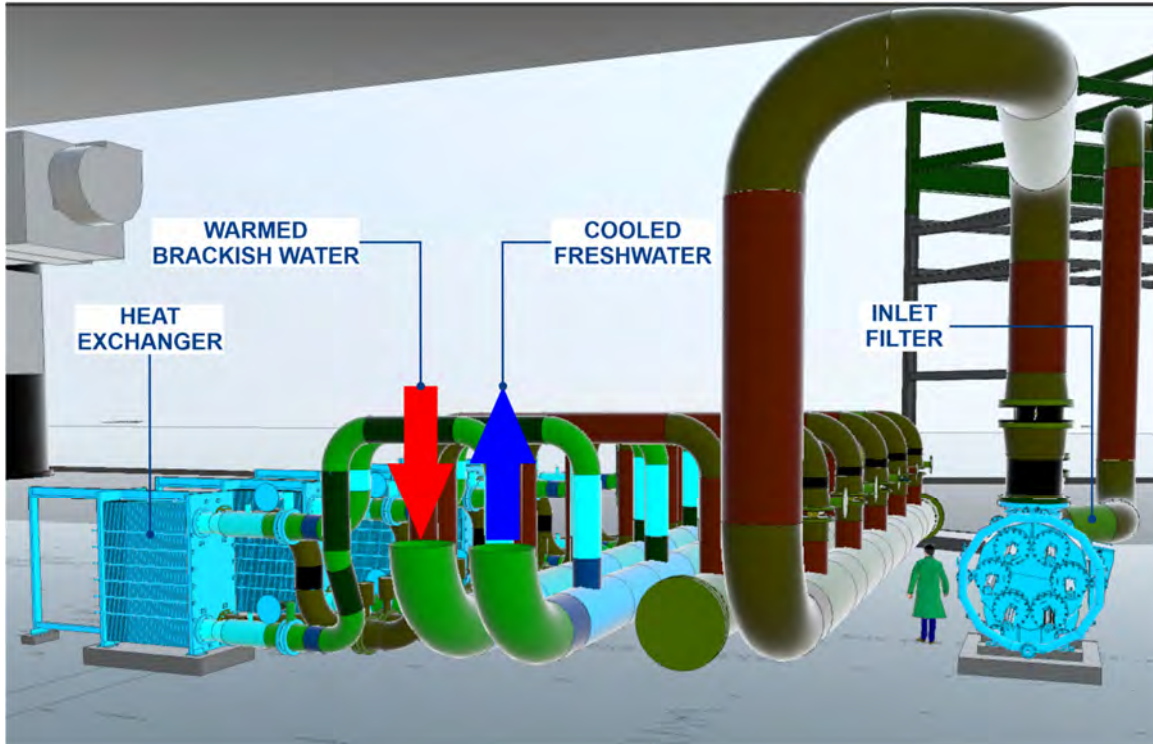

Figure 33. Three-dimensional model showing the heat exchangers proposed for water use reduction at the Reversing Falls Mill in Saint John, New Brunswick.

Table 15. Cooling performance of each heat exchanger in summer and winter as modelled for water use reduction at the Reversing Falls Mill in Saint John, New Brunswick.

Location	Performance Case			
	Summer		Winter	
	Fresh*	Brackish [†]	Fresh*	Brackish [†]
Flow ($\text{m}^3 \cdot \text{s}^{-1}$)	0.33	0.49	0.27	0.48
Inlet ($^{\circ}\text{C}$)	47.8	18.3	47.2	4.4
Outlet ($^{\circ}\text{C}$)	23.3	34.7	11.2	25.0
Delta ($^{\circ}\text{C}$)[‡]	-24.5	16.4	-36	20.6

NOTES:

*Water sourced from Spruce Lake, used within the Mill and reclaimed for reuse within the Mill

[†]Water sourced from the Saint John River and returned to the Saint John River

[‡]The difference between the inlet and outlet temperature

2.7.2.5 Warm Water Discharge

The warmed non-contact brackish water will be returned to the Saint John River. The water will not undergo any alteration other than a change in temperature.

2.7.2.6 Utilities and Ancillary Equipment

Power for the Mill is purchased through NB Power. It is supplied via an NB Power transmission line that connects with the Mill. Existing power distribution to the Mill is suitable for supplying the 575 volt three phase power requirements for the water use reduction component of the Project.

2.7.2.6.1 Lighting

For employee safety and for process and security monitoring, new exterior lighting will be installed on the exterior of the pumphouse. The light fixtures will be installed every 9 m to 12 m along the exterior approximately 4.6 m above grade. Those luminaries will be LEDs that shine downwards (*i.e.*, Streetworks OVF or equivalent). Design of the luminaries will be in accordance to that described in Section 2.7.1.8.1.8.

2.7.2.6.2 Design Standards

The design standards noted in Section 2.7.1.8.1.10 are also applicable to this part of the Project.

2.7.2.7 Water Use Reduction Summary

For future sustainability, the Mill needs to reduce its overall water consumption. To do this, the majority of non-contact cooling water sourced from the Spruce Lake Watershed will be collected, cooled, and then used in the pulping process. Doing so will reduce the overall quantity of freshwater sourced from the Spruce Lake Watershed and simultaneously reduce the Mill's total effluent volume. This component of the Project is critical to building and operating the ETF onsite, which will be the least disruptive to neighbours.

IPP's engineering team has incorporated several best-in-class technologies within the water use reduction design to yield additional environmental benefits. Those best-in-class technologies are summarized in Figure 34. This Project will place IPP among the global leaders in the manufacture of pulp and paper by reducing water consumption by up to 50 %.

WATER USE REDUCTION

BEST-IN-CLASS TECHNOLOGIES FOR ADDITIONAL ENVIRONMENTAL BENEFITS

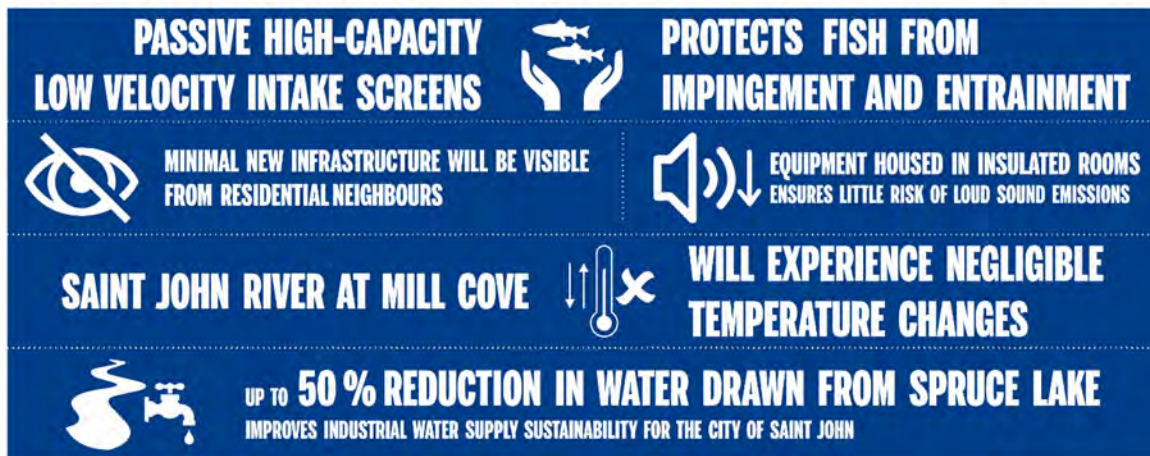

Figure 34. Summary of the best-in-class technologies to yield additional environmental benefits proposed for water use reduction at the Reversing Falls Mill in Saint John, New Brunswick.

2.8 PROJECT STAGES

The proposed Project will proceed in several Stages. Environmental permitting, monitoring, and compliance are a necessary component for all Stages of the proposed Undertaking. Each of the Stages is described below.

2.8.1 Stage I - Project Environmental Permitting, Monitoring, and Compliance

IPP is committed to environmental excellence. The Mill operates under an Environmental Management System (EMS), which is registered to the ISO 14001 standard. As part of the EMS, and in order to meet Provincial and Federal Regulations, IPP has established, implemented, and maintains an operational Emergency Response Plan and Environmental Contingency Plan (ERP&ECP) at the Mill. The ERP&ECP identify how personnel are required to respond to potential emergency situations and potential incidents promptly and to prevent or mitigate any associated adverse environmental impacts. Specific procedures within the ERP&ECP include, but are not limited to:

- environmental incident procedures;
- spill response;
- environmental incident reporting guidelines; and
- contingency procedures related to site specific tasks.

All employees and contractors working at the Mill are required to participate in a safety and environmental orientation program. IPP issues all participants of that program an environmental incident response procedure card that outlines the 3Cs that must be followed at the Mill in the event of an incident (*i.e.*, contain, contact, and clean-up). Project personnel will also be required to adhere to the Project-specific Environmental Protection Plan (EPP) that will be developed prior to completing any onsite construction works related to the Project.

Standard operating procedures, basic care procedures, and contingency procedures will be developed for the new environmental treatment facility and water use reduction project. Those procedures will be incorporated into IPP's existing EMS. On a go-forward basis, IPP will ensure all Project personnel implement, comply with, and follow those new procedures included in the EMS.

2.8.1.1 Existing Approvals

The Mill currently has Approvals To Operate (ATOs) as per the Air Quality Regulation [97-133] of the New Brunswick *Clean Air Act* [S.N.B. 1997, c C-5.2] (i.e., ATO I-9509) and Water Quality Regulation [82-126] of the New Brunswick *Clean Environment Act* [R.S.N.B. 1973, c C-6] (i.e., ATO I-11495). Copies of those ATOs are included in Appendix II. Both ATOs are for reference production rates from the Mill up to 1 000 ADMT of bleached Kraft pulp and 200 machine dry tonnes per day of tissue. Environmental monitoring at the Mill will continue to occur on a routine and a long-term basis as set out in the existing ATOs. Compliance will be ensured through the regular reporting, as outlined in the ATOs, to the regulatory authority.

2.8.2 Stage II - Project Construction

The Project will be confined to the boundaries of the existing active Mill site. An approximate quantity summary of the main Project construction materials is provided in Table 16. Although not an exhaustive list, the heavy equipment that may be used during Project construction is summarized in Table 17. The various aspects of Project construction are described in the sections that follow.

Table 16. Summary of the main construction materials for the environmental treatment facility and water use reduction project proposed for the Reversing Falls Mill in Saint John, New Brunswick.

Component	Approximate Quantity
Piping (above and below ground)	15 250 m
Concrete (cast in place)	9 200 m ³
Masonry block	600 m ³
Structural steel	522 tonnes
Electrical cable	61 000 m
General material excavation	15 300 m ³
Rock excavation	35 200 m ³

Table 17. Typical list of heavy equipment anticipated for use during construction of the environmental treatment facility and water use reduction project proposed for the Reversing Falls Mill in Saint John, New Brunswick.

Equipment Use / Type	Typical Task
<u>CONSTRUCTION TRAILER MOBILIZATION, SURVEYING, AND GENERAL LABOUR</u>	
Semi-trailer truck	Moving trailers to site
Pick-up support truck or van	Transport of equipment and personnel
<u>MATERIAL EXCAVATION, BACKFILLING, AND SPREADING AND SERVICES INSTALLATION</u>	
Dump truck	Hauling excavated material and backfill
Semi-trailer truck and float	Floating equipment to and from the site
Compactor / roller	Fill compaction
Loader	Material movement
Bulldozer	Material movement
Tracked excavator	Material movement
Micro-tunnelling machine	Installation of cooling water intake pipe
<u>STRUCTURAL FOUNDATIONS</u>	
Crawler crane (27 t to 440 t) equipped with fixed or hanging lead configuration	Driving H-piles
Carry deck (8 t to 22 t)	Movement of heavy equipment about the site
Semi-trailer truck and float	Floating equipment to and from the site
Welding truck	Base-stations for welding equipment
Forklift / loader	Movement of pre-cast members about the site and materials handling
Concrete truck	Hauling concrete to the site
Concrete pumper truck	Movement of concrete about the site
Concrete pumps and vibratory equipment	Placing and compacting of concrete
<u>STEEL MEMBERS AND BUILDING ENVELOPES</u>	
Semi-trailer truck and trailer	Transport of structural steel and building materials to the site
Semi-trailer truck and float	Floating equipment to and from the site
Crane (110 t to 650 t)	Movement and placement of structural steel members
Truck crane (40 t to 90 t)	Movement and placement of structural steel members
Hydraulic boom truck (10 t to 40 t)	Movement and placement of building materials
Welding truck	Base-stations for welding equipment
Self-propelled elevating work platforms	Safely positioning personnel in above-ground areas
Forklift / loader	Movement of pre-cast members about the site, materials unloading, and materials handling
<u>EQUIPMENT INSTALLATION</u>	
Semi-trailer truck and trailer	Transport of equipment to the site
Container handler	Moving containers around the site
Semi-trailer truck and tilt bed trailer	Moving containers and equipment into the buildings
Semi-trailer truck and flatbed trailer	Moving equipment into the buildings
Rough terrain crane (130 t)	Installing equipment inside the buildings
Crawler crane (100 t)	Installing equipment inside the buildings
Transporter	Moving equipment into lifting position
Crane (50 t)	Setting equipment on transporter
Rough terrain crane (150 t)	Setting heavy equipment into place
Hydraulic crane (500 t)	Lifting cooling water pipeline rack into place

Equipment Use / Type	Typical Task
Warehouse forklift	Movement and storage of equipment in the buildings
Self-propelled elevating work platforms	Safely positioning personnel in above-ground areas
Telehandler (2 250 kg capacity)	Safely positioning personnel in above-ground areas

GENERAL CONSTRUCTION EQUIPMENT

Compressors	Operating pneumatic tools
Pumps	Pumping water from excavations
Generators	Supplying localized power
Heaters	Heating work areas
Lighting plants	Lighting work areas
Asphalt paving machine	Laying asphalt
Loader with sweeper	Sweeping roadway surfaces

2.8.2.1 Temporary Infrastructure and Supporting Facilities

Prior to Project construction, several contractor trailers will be brought on to the Mill site. Those trailers will serve as construction offices throughout Project development. Temporary services will be connected to those facilities. Locations proposed for contractor trailers are shown in Figure 35.

There are several surface parking lots on the Mill property. As shown in Figure 35, IPP has designated one parking lot area for this Project (*i.e.*, the former Simms Factory site). Contractors bringing their own vehicle to the site will be required to park their vehicle in that designated parking lot.

Materials being delivered to the Project site can enter using one of the designated entrances (Figure 35). Those entrances will also be used by heavy equipment going to and from the Project site and by Project personnel. Laydown required for large Project infrastructure will be confined to the wood yard area of the Mill site. Those areas may also be used for the storage of general construction materials.

Temporary washroom facilities may be brought onsite for the duration of Project construction. Any temporary washrooms will be maintained by licensed and approved third-party contractors who will be required to regularly service the facilities.



Figure 35. Aerial photograph of the Reversing Falls Mill in Saint John, New Brunswick showing the locations proposed for contractor project trailers, project parking areas, material laydown areas, and construction entrances for construction of the proposed environmental treatment facility and water use reduction project.

2.8.2.2 Services and Excavations

No green field areas are involved in this Project. Rock and material excavation will be required to achieve base elevations for the ETF. Approximately 6 000 m³ of rock will be removed using pneumatic hammers.

The bedrock that will be removed belongs to the Brookville Gneiss formation of the New River Plutonic Suite, which is described later in Section 3.1.6.1. The bedrock belongs to the same formation that is quarried by Gulf Operators at the nearby Bald Mountain site. The rock has previously been tested and is not acid generating.

Site surveying was previously completed so that engineering design could begin. Additional site surveying will be required throughout Project construction in order to precisely position equipment at the site.

The majority of the building and equipment will be founded on bedrock that is at or very near the surface. It is expected that excavation will be minimal. Excavated materials will likely include a mixture of native soils and rock with some minor wood chips, asphalt, and concrete. All general and suitable excavated material will be reused onsite. Some of the

site will need to be built up using clean rock and / or pit run gravel. It is estimated that about 24 000 m³ will be required, which will most likely be sourced from Gulf Operators' Bald Mountain site (*n.b.*, a private roadway already exists between the two sites, which will minimize traffic on local roadways).

2.8.2.3 Structural Foundations

A portion of the ETF process building, a portion of the EQ tank, the cooling water pumphouse, the cooling water intake line, and the cooling water pipe bridge will all be supported on Steel H piles driven to bedrock. The total number of piles estimated for the Project is 210 for a total linear length of 750 m. It is anticipated that the piles would be driven over a one month period and suitable notification will be provided to neighbours in advance of the work.

The H piles will be driven into the ground using a crane equipped with a fixed or hanging lead configuration pile driver. It is likely that a hydraulic hammer will be used; however, a diesel hammer may also be used depending on hydraulic hammer availability. The steel piles will be connected at grade using concrete pile caps cast in place.

2.8.2.4 Work Hours

During construction, onsite activities will be continuous. Loud work that has the potential to disturb neighbours (*e.g.*, pile driving, *etc.*), will normally be done between the regular work hours of 7 AM to 7 PM Monday through Friday. Crews working outside of those regular work hours will be sensitive to neighbours and will, whenever practical, confine loud work to regular work hours.

A reduced construction crew may be used when working on Saturdays, Sundays, and evenings. Tie-in work (*i.e.*, connecting the new units to the Mill), which requires Mill shutdowns, will be completed 24 hours · day⁻¹, seven days a week in order to limit shutdown duration.

2.8.2.5 Labour

It is estimated that approximately 240 000 person hours of work (*i.e.*, 120 person years) will be generated through construction of the ETF. A breakdown of the labour required to complete that component of the Project is provided in Figure 36. At peak construction, it is projected that up to 130 contractor employees will be onsite. The resources required to construct the water use reduction portion of the Project has not yet been determined; however, it is estimated that there will be about 40 to 100 contract employees onsite during construction of those Project components.

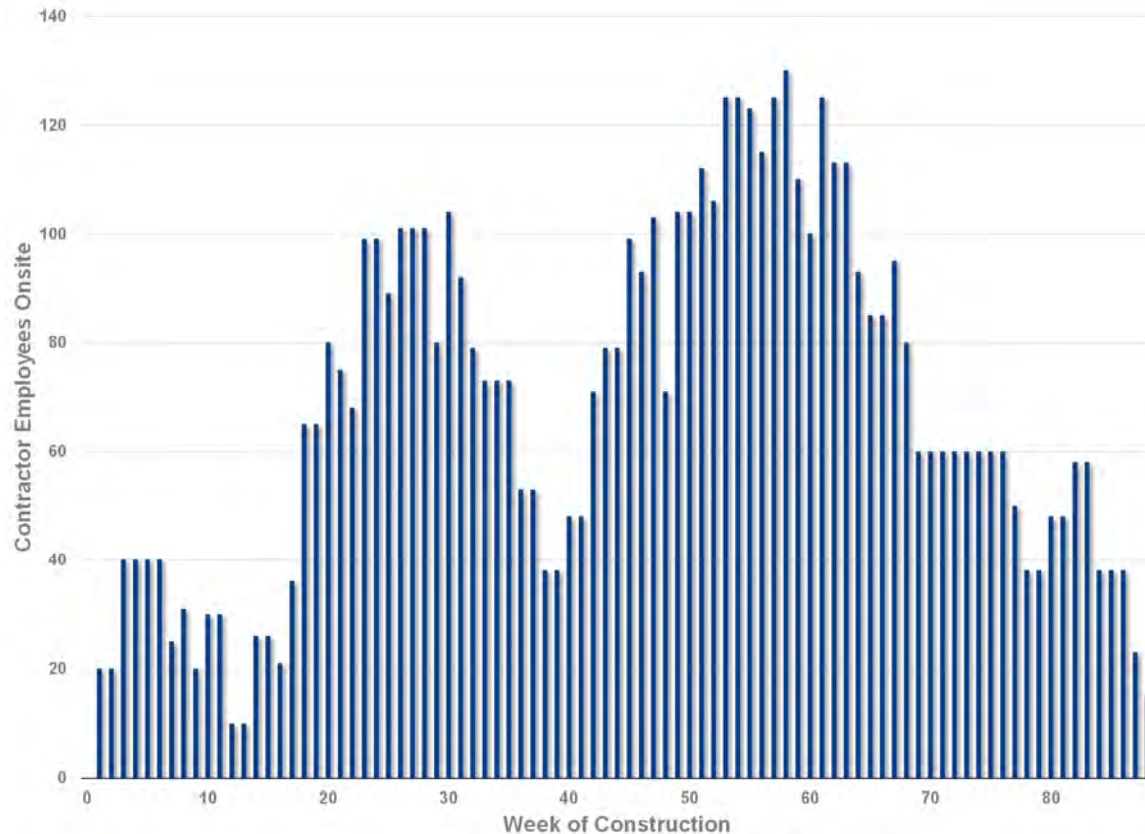

Figure 36. Estimated labour required to construct the environmental treatment facility proposed for the Reversing Falls Mill in Saint John, New Brunswick.

2.8.2.6 Site Access

Access to the Mill for routine deliveries and shipping (e.g., chemicals, wood chips, Kraft pulp, etc.) by road and rail will not be affected by Project construction. Operational and maintenance personnel for regular Mill processes will continue to access the site via the main gatehouse (Figure 35). Project construction equipment and personnel will enter and exit the site through the existing Mill access points.

2.8.2.7 Traffic

The Mill is constantly undergoing routine maintenance operations and planned upgrades. That work results in regular peaks and valleys in local area traffic. The existing all-weather road networks are designed to accommodate those fluctuations. It is not anticipated that there will be any issues with offsite traffic during Project construction.

During peak Project construction (i.e., a 27 month period), truck traffic to and from the Mill will slightly increase as materials are delivered. Reasonable efforts will be made to ensure that increased traffic loads on local truck routes are confined to non-peak travel times (i.e., not during morning or evening rush hour traffic). During the movement of over-sized and / or heavy loads, there may be a requirement to have traffic controls in place, such as flagging crews or police escorts.

2.8.2.8 Safety

Employee and contractor safety is a vital part of the culture at IPP. For example, one of IPP's goals is to provide a safe and healthy work environment for all employees, contractors, and visitors. As previously noted, all employees and contractors working at the Mill are required to take part in a safety and environmental orientation program. Participants are provided a safety and environmental booklet and environmental reporting procedure wallet card that explains the safety and environmental protocols in place at the Mill. Employees and contractors are required to adhere to the established safety practices, which include:

- lockout tagout for isolating equipment;
- confined space and special entry;
- barrier tapes; and
- Mill alarms and evacuation.

All Project personnel will be required to participate in the Mill safety and environmental orientation program in addition to any Project-specific orientation. They will also be required to use specific and appropriate safety policies. For example, contractors working inside any tanks or vessels must adhere to the confined space and special entry policy.

Safety concerns identified by Project personnel will be resolved as they arise; however, as per the New Brunswick *Occupational Health and Safety Act* [**S.N.B. 1983, c O-0.2**] (*OHSA*) the Mill operates with a Joint Occupational Health and Safety Committee (JOHSC). The JOHSC addresses safety concerns as necessary. Depending on the number of contractors on site and the duration of the Project construction stage, a contractor JOHSC may be formed to address safety concerns brought forward by contract employees. In addition to the safety practices in place, all other safety standards and / or requirements under the *OHSA* will be followed and enforced.

2.8.2.9 Commissioning

Following construction and prior to operation of the ETF, IPP will execute a rigorous check out and commissioning process. IPP's check out and commissioning process has proven to be very successful and was developed in-house during many years of successful project startups, such as the continuous cooking digester project. A very detailed list of items to check out will be meticulously reviewed. All of the field instruments and systems will be inspected and checked for functionality while the system is dry. The system will then be commissioned using clean water to check for potential leaks and again verify instruments are reading and functioning properly.

When IPP's startup team believes the ETF is ready to receive effluent from the Mill, the system will be fed a small volume of effluent. During startup, all of the current in Mill systems, including the existing MBBR, will continue to operate. Continued operation of the pollution prevention equipment during startup will ensure continued PPER compliance throughout the startup process. The testing and monitoring of the ETF's biological growth and BOD / COD removal will be used to increase the effluent feed to the new system, while reducing the feed to the existing MBBR.

IPP is confident that environmental compliance will be maintained given their rigorous pollution prevention investments, modernized mill equipment, and highly knowledgeable and skilled workforce,

2.8.3 Stage III - Project Operation and Maintenance

Once commissioned and approved, the new environmental treatment facility and water use reduction project will operate continuously. Similar to other Mill operations, these processes will operate 24 hours per day, 7 days a week, and 365 days per year. The only exception to this will be during planned maintenance shutdowns. There will be a slight increase in the current compliment of employees at the Mill as a result of this Project. It is expected that five full-time trained employees will be required to operate the ETF (*n.b.*, this is one operator per shift with two additional operators for vacations and sick leave).

The ETF will operate at anticipated average daily flows of 70 000 m³ and peak daily flows of 90 000 m³. Treated effluent will be discharged to the Saint John River via the Main Mill Outfall. Fibre collected during the screening process and dewatered solids ranging from 387 m³ · day⁻¹ to 1 725 m³ · day⁻¹ will either be sent to the onsite biomass boiler or to an offsite compost facility. The onsite biomass boiler is used for electricity generation, which offsets CO₂ emissions through the displacement of other fossil fuels.

Routine truck deliveries of chemicals for dosing (*i.e.*, sulfuric acid, sodium hydroxide, urea, and phosphoric acid) will occur regularly throughout the week. Trucks will be scheduled so that deliveries are offset. It is estimated that nitrogen and phosphorous will be consumed at a rate of 900 kg · day⁻¹ and 80 kg · day⁻¹, respectively. This translates to truck deliveries of about once per week.

Preventative maintenance tasks and equipment cleaning will also be completed on an as required basis to help ensure system reliability (*n.b.*, back-ups have been built into the systems to ensure unplanned downtime is minimized). Extensive inspections and overhauls, as required, will be conducted every 18 months when the main Mill shutdowns occur.

Procedures will be developed to continue operation of the ETF during main Mill shutdowns. During those periods, there will be reduced flow and loading to the ETF. The biological environment will have to be adjusted to maintain the growth media during the reduced biological loading. The overall objective of the operators will be to maintain a healthy microorganism population so that once the shutdown is complete, performance of the ETF can ramp-up with the resumption of Mill production.

The water use reduction component of the Project will be designed to accommodate regular inspections and maintenance. Underwater inspections and maintenance may require the use of dive teams.

As with other Mill operations, best-management practices and modern environmental protection measures will be employed throughout the 50 year operational lifespan of the Project. Throughout operations, monitoring of effluent quality will be undertaken by IPP personnel and / or accredited third-party laboratories to assess compliance with regulations.

2.8.4 Stage IV - Project Decommissioning

The Project has a predicted lifespan of 50 years. Environmental protection measures are continually evolving and improving. Therefore, specific protection measures regarding the decommissioning / abandonment of the Project cannot adequately or appropriately be made at this time. The decommissioning / abandonment will be subject to future study for assessing the environmental impacts and how the activities can be done in an environmentally appropriate manner.

2.8.5 Stage V - Mishaps, Errors, and / or Unforeseen Events

With any Project, there is always the possibility of a mishap, errors, and / or unforeseen events. Those instances may happen during this Project and the Proponent will mitigate them by taking a systematic approach to safeguarding public and personnel health and safety by establishing a safe culture during Project implementation. The IPP Environmental Spill Response Plan will be used throughout the life of the Project. Under that plan, all spills are reported, immediately contained, and cleaned up as soon as they occur. Where required, Environmental Protection Plan procedures will be developed specifically for this Project and may include contingency measures in the event that mishap, errors, and / or unforeseen events occur.

2.9 PROJECT SCHEDULE

Project construction activities are expected to begin immediately following the granting of a successful EIA determination and issuance of all applicable construction permits. The Project Team is aiming for a construction start date in Q4 2022. A high-level construction schedule is shown in Figure 37. Depending on business conditions, the schedule presented could be shifted out by up to 18 months.

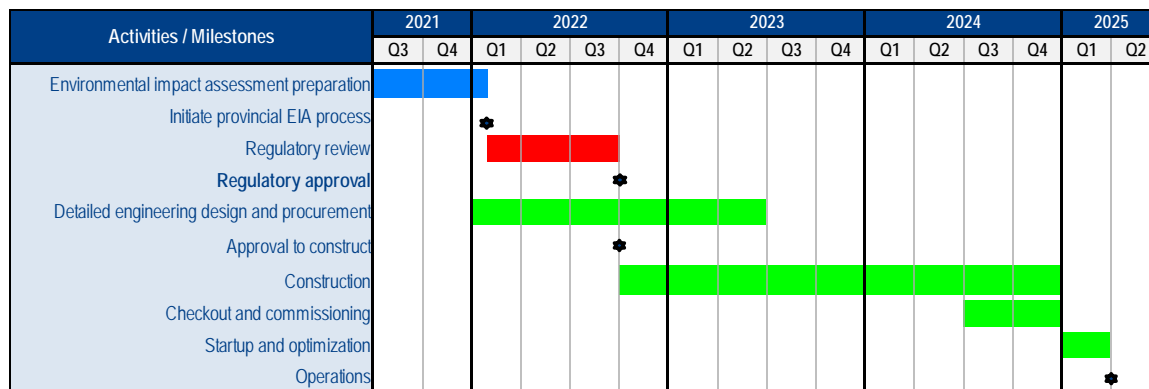

Figure 37. High-level project Gantt chart for the construction of the environmental treatment facility and water use reduction project proposed for the Reversing Falls Mill in Saint John, New Brunswick.

3.0 DESCRIPTION OF THE EXISTING / BASELINE ENVIRONMENT

This section describes the existing environment, pre-Project, at and in the vicinity of the Reversing Falls Mill. The information contained in this section is considered to be baseline information for this Project and can be used for comparison to post-Project data to assess any potential impacts. Within this section, “regional” refers to the City of Saint John, which includes the rural, suburban, and urban centres around the Reversing Falls Mill. Those areas include, but are not limited to, the west side (*i.e.*, Carleton, Lancaster, and Fairville), the east side (*i.e.*, Simonds and Loch Lomond), the north end (*i.e.*, Pokiok, Millidgeville, Mount Pleasant, and Portland), and the south end (*i.e.*, central peninsula and Uptown). Where specifically defined, the term “local” refers to the Mill site proper and the area immediately surrounding the site (*i.e.*, a 500 m buffer with a particular focus on Milford).

3.1 PHYSIO-CHEMICAL ENVIRONMENT

3.1.1 Climate

Saint John exists within the Fundy Coast ecoregion of New Brunswick [*Hinds*, 2000]. According to the Köppen-Geiger climate classification, the region is characterized by a humid continental climate [*Peel et al.*, 2007]. The Bay of Fundy, which is a large heat sink that never fully freezes or warms (*i.e.*, temperatures average between 8 °C and 12 °C), influences the climate by generally providing cool summers and mild winters compared to inland locations.

Monthly climate data between 1947 and 2008 are available for the meteorological station at the Saint John Airport (YSJ). That station is part of the World Meteorological Organization (WMO) climate monitoring system (WMO ID 71609; 45.32 °N 65.89 °W, elevation 108.8 m). During that period, the mean annual temperature was 5.0 °C ± 0.73 °C (Figure 38) with a monthly daily minimum of - 7.8 °C ± 2.38 °C in January to a monthly daily maximum of 17.0 °C ± 0.84 °C in August [*ECCC*, 2021a]. The warmest and coolest years on record were 1953 and 1948, respectively, when the mean annual temperature was 6.9 °C and 3.8 °C. The extreme minimum mean daily temperature of - 36.7 °C was measured on 11 February 1948. In contrast, the extreme maximum mean daily temperature of 34.4 °C was measured on 22 August 1976.

Precipitation (*i.e.*, rain, drizzle, freezing drizzle, hail, snow, *etc.*) is generally well distributed throughout all months and the majority (> 80 %) falls in the form of rain. Mean annual precipitation between 1947 and 2008 (Figure 39) was 1 379 mm with a mean monthly low of 90 mm in August to a mean monthly high of 148 mm in December [*ECCC*, 2021a]. The driest year on record was 2001 when there was only 799 mm of precipitation. Conversely, the wettest year was 1979 when 1 975 mm of precipitation fell. The most extreme daily rainfall of 154.4 mm was measured on 13 November 1975. The greatest snowfall of 58.2 cm was recorded on 12 December 1960. Snow depth, during the seven months with snowfall, averages 8.6 cm and almost 158 days each year experience some form of precipitation.

Marine fog, which varies seasonally and is more common during the summer, averages 590 hours · year⁻¹ in the region; however, visibility is normally good at > 9 km about 77 % of the time [*ECCC*, 2021a]. Annual sunshine is approximately 1 947 hours ranging from

97 hours in November to 226 hours in July. The extreme amount of daily sunshine (i.e., 15.2 hours) occurred on 26 June 1978.

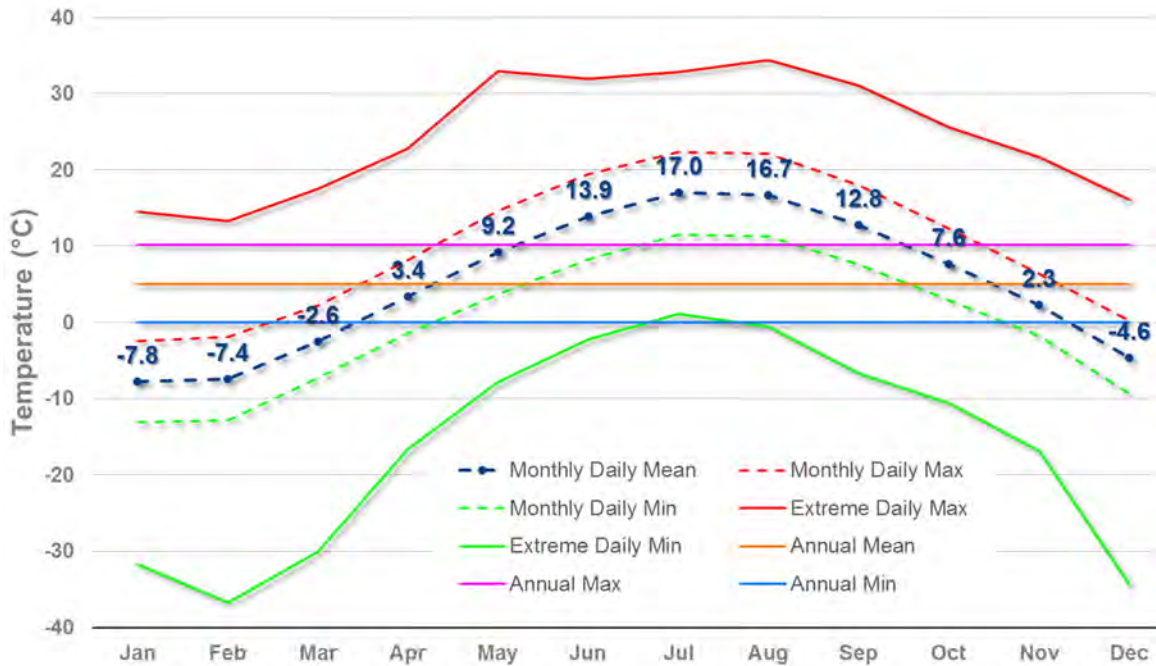

Figure 38. Compilation of mean daily temperatures measured at the YSJ meteorological station between 1947 and 2008.

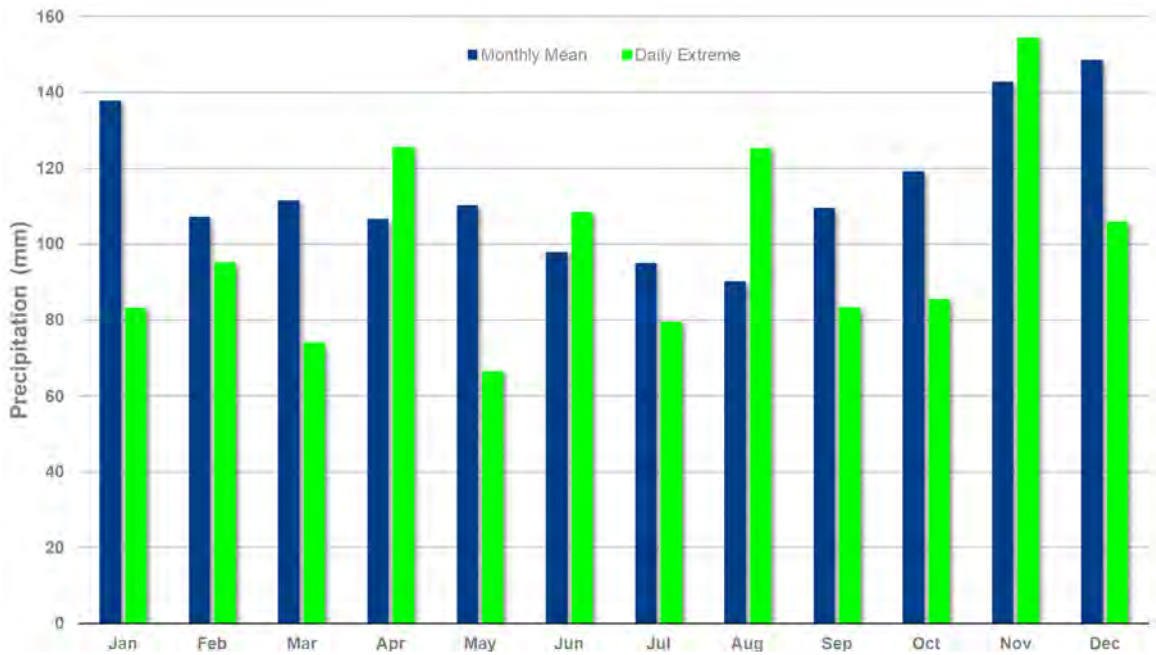

Figure 39. Compilation of mean daily precipitation measured at the YSJ meteorological station between 1947 and 2008.

Average wind speed measurements at YSJ are not available for the same period as the data previously discussed. Data are only available between 1981 and 2010. Wind speed

varies from $12.1 \text{ km} \cdot \text{hour}^{-1}$ in August to $18.6 \text{ km} \cdot \text{hour}^{-1}$ in March yielding an annual average of $16.1 \text{ km} \cdot \text{hour}^{-1}$ [ECCC, 2021a]. The winds predominantly blow from the south (*i.e.*, off the Bay of Fundy), but are also frequent from the northwest (*i.e.*, off the land towards the Bay of Fundy). Winds tend to be the strongest in the winter and weakest in the summer (Figure 40). The maximum hourly wind speed of $111 \text{ km} \cdot \text{hour}^{-1}$ was measured on 9 January 1978. The most extreme wind gusts of $146 \text{ km} \cdot \text{hour}^{-1}$ (south winds) were recorded on 2 February 1976 during the *Groundhog Day Gale*.



Figure 40. Compilation of wind speeds measured for the 30 year period between 1981 and 2010 at the Saint John Station A (*i.e.*, Saint John airport).

3.1.2 Air Quality

3.1.2.1 Objectives

The NBDELG recognizes several air quality objectives and standards; some are regulated while others are voluntary. Table 18 summarizes the air quality objectives as per the New Brunswick *Clean Air Act* [S.N.B. 1997, c. C-5.2]. The air quality objective provided for ground-level ozone is the national objective because there is not a legally-binding limit in New Brunswick.

Table 18. New Brunswick ambient air quality objectives as per the New Brunswick *Clean Air Act* [S.N.B. 1997, c. C-5.2].

Pollutant	Units	Averaging Period			
		1 hr	8 hr	24 hr	1 yr
Carbon Monoxide (CO)	ppm	30	13		
Hydrogen Sulphide (H ₂ S)	ppb	11		3.5	
Nitrogen Dioxide (NO ₂)	ppb	210		105	52
Sulphur Dioxide (SO ₂)*	ppb	339 (169.5)		113 (56.5)	23 (11.5)
Total Suspended Particulates (TSS)	µg · m ⁻³			120	70
Ozone (O ₃)†	ppb	82		25	15

NOTES:

*Objectives are 50 % lower in Saint John, Charlotte, and Kings Counties (*i.e.*, shown in brackets)

†National ambient air quality objective (*i.e.*, acceptable level)

3.1.2.2 Monitoring

Air quality monitoring in Saint John began in the early 1970s. The air quality-monitoring program was established to assess the airshed with respect to various common industrial pollutants. In Saint John today, air quality is monitored at three NBDELG sites. The quality assured data from the NBDELG sites can be accessed from Environment Canada's National Air Pollution Surveillance (NAPS) Program website. Mean annual data, where available, for carbon monoxide (CO), nitrogen dioxide (NO₂), sulfur dioxide (SO₂), ozone (O₃), and particulate matter (PM_{2.5}) are available from the NAPS. Those data are plotted in Figure 41. Generally, there has been a continual improvement in Saint John's air quality over time.

Carbon monoxide data have only been monitored in Uptown Saint John (Figure 41). Those data ($n = 31$ years between 1980 and 2019) show that CO concentrations in the Saint John airshed have historically been 0.5 parts per million (ppm) \pm 0.33 ppm. The mean annual CO concentrations have ranged from a maximum of 1.40 ppm (1983) to a minimum of 0.16 ppm (2017, 2018, and 2019). The overall trend for the 40 year period indicates that CO concentrations have been slowly declining. This is attributed to advances in air emissions technology and the subsequent decrease in CO emissions from industry and vehicles.

Similar to mean annual CO concentrations, mean annual concentrations of NO₂ have exhibited a downward trend in Saint John (Figure 41). The Uptown monitoring site has the largest number of datum points ($n = 29$). The mean annual concentration for that site between 1981 and 2019 was 9.6 ppb \pm 4.12 parts per billion (ppb) and ranged from a low of 3.0 ppb in 2009 to a high of 19.0 ppb in 1987. All mean annual concentrations are well below the 52 ppb air quality objective limit set by the NBDELG.

Sulfur dioxide concentrations have also exhibited a downward trend in Saint John. Uptown Saint John, where data are the most complete, yielded a 37 year (*i.e.*, between 1974 and 2019) annual mean of 5.3 ppb \pm 5.11 ppb (Figure 41). Mean annual concentrations in east Saint John were slightly higher at 6.3 ppb \pm 5.05 ppb ($n = 29$).

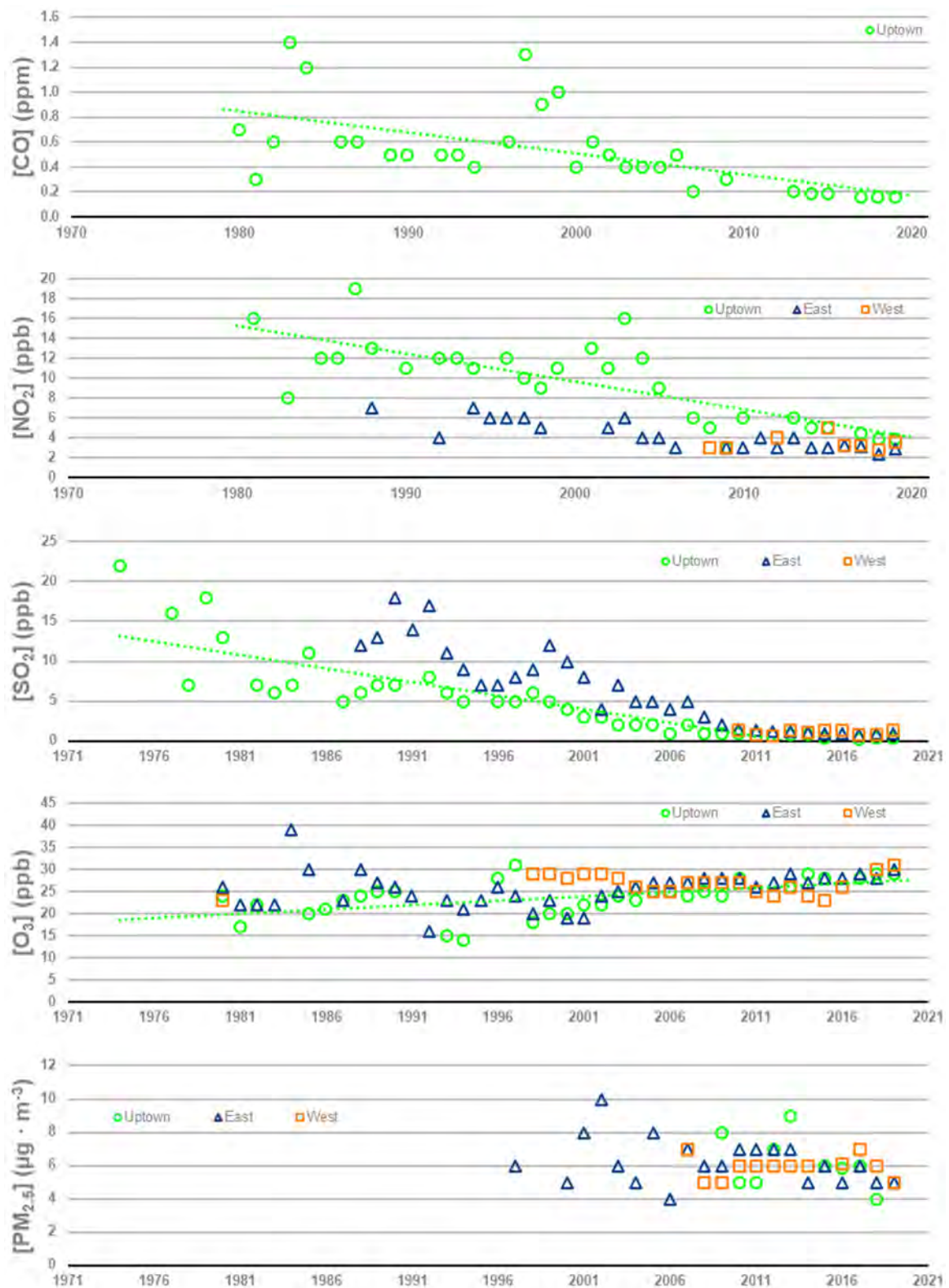

Figure 41. Mean annual air quality data as measured at NBDELG monitoring locations in Uptown, east, and west Saint John, New Brunswick between 1974 and 2019.

Ozone data are available at the sites starting in 1980 (Figure 41). There has been an overall upward trend in Uptown and east Saint John, but a slight downward trend in west Saint John; however, almost all annual values have been above the NB air quality objective of 15 ppb. The mean annual concentration in Uptown, east, and west Saint John was calculated to be $23.7 \text{ ppb} \pm 4.14 \text{ ppb}$ ($n = 32$), $25.6 \text{ ppb} \pm 4.02 \text{ ppb}$ ($n = 39$), and $26.4 \text{ ppb} \pm 1.98 \text{ ppb}$ ($n = 20$), respectively.

Particulate Matter in the 2.5 micron or less range (*i.e.*, $\text{PM}_{2.5}$) started being measured at the NBDELG monitoring sites in 1997 (Figure 41). The highest annual concentrations were measured in east Saint John with a mean of $6.2 \mu\text{g} \cdot \text{m}^{-3} \pm 1.38 \mu\text{g} \cdot \text{m}^{-3}$ ($n = 21$). Mean annual concentrations in Uptown and west Saint John were, respectively, $6.2 \mu\text{g} \cdot \text{m}^{-3} \pm 1.57 \mu\text{g} \cdot \text{m}^{-3}$ ($n = 9$) and $5.9 \mu\text{g} \cdot \text{m}^{-3} \pm 0.67 \mu\text{g} \cdot \text{m}^{-3}$ ($n = 12$). Although the levels are fairly static, they are considerably below the annual air quality objective limit of $70 \mu\text{g} \cdot \text{m}^{-3}$ set by the NBDELG.

3.1.2.3 National Pollutant Release Inventory Reporting

In addition to air quality monitoring sites, many industrial facilities are required, as per the *Canadian Environmental Protection Act, 1999* [S.C. 1999, c. 33], to annually report their emissions to the National Pollutant Release Inventory (NPRI) administered by Environment Canada. The NPRI is Canada's legislated, publicly accessible inventory of pollutant releases (*i.e.*, to air, water, and land), disposals, and transfers for recycling. In the greater Saint John area, there are at least nine facilities (Figure 42) that are required, based on meeting thresholds, to report their air emissions. Those numbers complement our understanding of the air quality for greater Saint John. The most recent non-preliminary data available (*i.e.*, 2019 emissions data) for facilities in the greater Saint John area are summarized in Table 19 [NPRI, 2021].

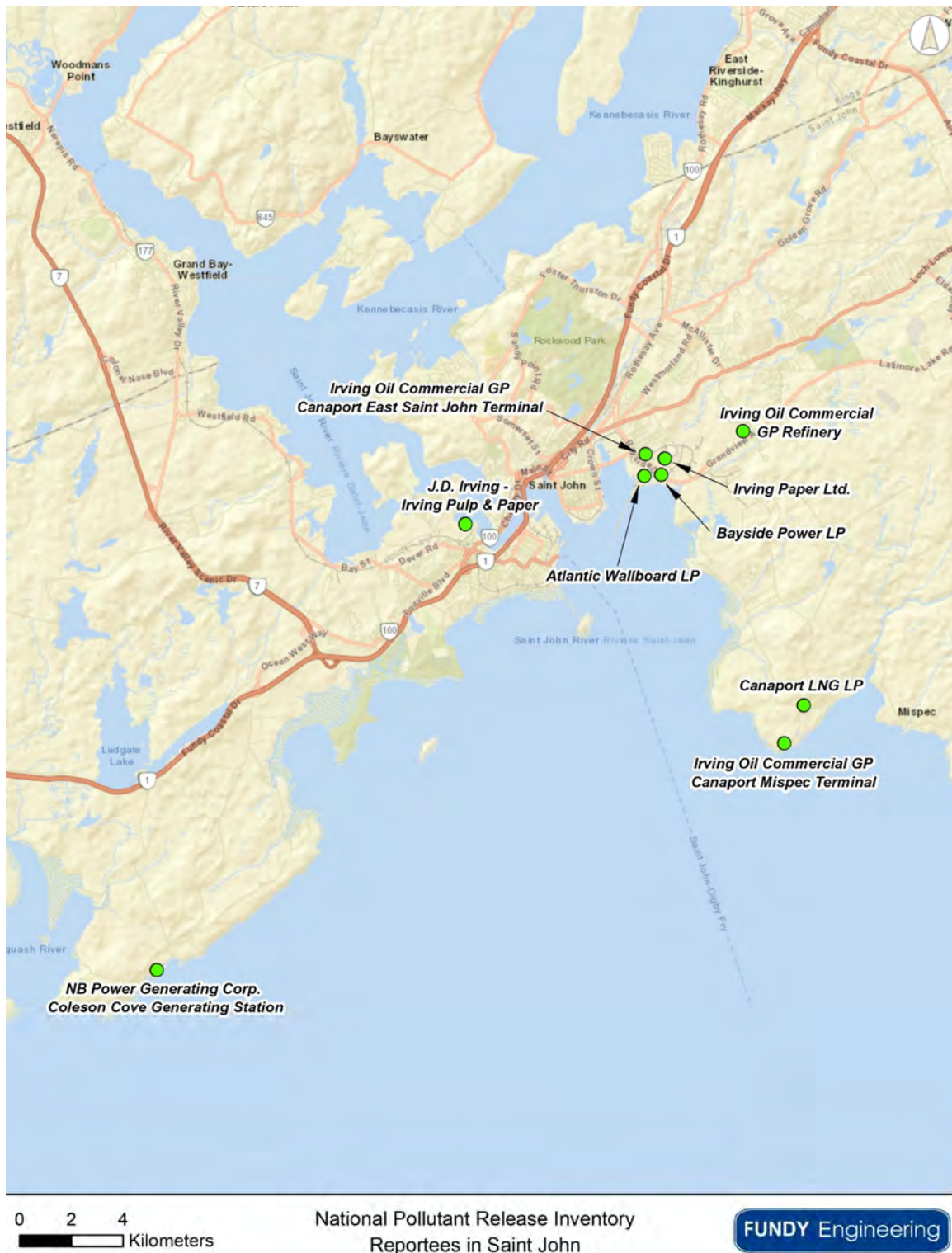

Figure 42. Facilities in the greater Saint John area that are required to annually report emissions to Environment Canada’s National Pollutant Release Inventory tracking database.

Table 19. Air emissions data, circa 2019, for facilities in greater Saint John that reported to Environment Canada's National Pollutant Release Inventory tracking database.

Reporting Facility	Air Emissions (t · yr ⁻¹)						
	CO	NO ₂	PM	PM ₁₀	PM _{2.5}	SO ₂	VOC
Atlantic Wallboard L.P.	18.159	25.054	5.271				
Bayside Power L.P.		54.7	6.05	6.05	6.05		
Canaport™ LNG LP				0.8259	0.8259		
Irving Oil Commercial G.P. - Canaport Mispic Terminal							46.852
Irving Oil Commercial G.P. - Canaport East Saint John Terminal							67.813
Irving Oil Commercial G.P. – Refinery	1 005.18	2578.88	441.957	341.701	239.85	2 006.869	390.185
Irving Paper Limited	60.804	178.953		7.282	6.391		45.758
JD Irving - Irving Pulp and Paper	2 215.149	991.355	129.985	96.915	63.274	798.858	207.491
NB Power Generation Corp. - Coleson Cove Generating Station	42.94	268.73	2.29	2.29	2.22	611.18	0.176

3.1.2.4 Greenhouse Gas Reporting Program

GreenHouse Gas (GHG) emissions (*i.e.*, carbon dioxide, methane, nitrous oxide, hydrofluorocarbons, perfluorocarbons, sulphur hexafluoride, and nitrogen trifluoride) are believed to be contributors to accelerated climate change. GHG emissions summaries are available between 1990 and 2019 for all provinces, territories, and Canada, and for the World between 1990 and 2018. The emissions summaries comprise total emissions from: energy activities (*i.e.*, stationary combustion sources, transportation, and fugitive sources); industrial processes (*e.g.*, mineral products, chemical industry, metal production, *etc.*); solvent and other product use; agriculture (*i.e.*, fermentation, manure management, soils management, and field burning); and waste activities (*i.e.*, wastewater handling, incineration, and landfills) [ECCC, 2021b]. The data are summarized in Table 20.

Although there have been efforts to curb and reduce GHG emissions, global GHG emissions continue to steadily increase (Table 20 and Figure 43). This is largely due to the increase in emissions from developing countries. Comparatively, Canadian emissions exhibited a sharp downward trend between 2007 and 2009, which was likely due to increased awareness and the implementation of newer technologies to reduce GHG emissions; however, since 2009, emissions have been on the upswing. All provinces, with the exception of Alberta, British Columbia, Manitoba, Saskatchewan, and Newfoundland, (*i.e.*, all large fossil fuel extracting provinces) and Nunavut and the Yukon (*i.e.*, developing provinces), have shown a decrease in GHG emissions. Between 1990 and 2019, New Brunswick's GHG emissions decreased by about 24 % while Canada's overall emissions increased.

In order to assess Canada's overall environmental performance and contribution to GHG emissions, the Canadian Government announced the introduction of the Greenhouse Gas Emissions Reporting Program (GHGRP) in March 2004. Through the GHGRP, all facilities that emit the equivalent of 50 000 tonnes or more of GHGs in carbon dioxide equivalent

units (CO_{2eq}) per year from stationary combustion, industrial processes, venting, flaring, fugitives, and onsite transportation, waste, and wastewater sources are required to report. Facilities falling below the threshold are not obligated to report, but they may do so voluntarily.

Table 20. Provincial and territorial, national, and global greenhouse gas emissions data for five year increments since 1990 and for the last three years with available data. Data from *ECCC* [2021b] and *WRI* [2021].

Region	Kilotonnes of Carbon Dioxide Equivalent Units (kt CO _{2eq})									Change*
	1990	1995	2000	2005	2010	2015	2017	2018	2019	
AB	171 785	201 223	227 744	235 479	247 714	278 394	271 013	272 494	27 5846	161 %
BC	51 783	60 178	64 991	62 973	59 023	59 247	63 168	65 529	65 689	127 %
MB	18 599	19 873	21 184	20 634	19 696	21 223	22 167	22 986	22 647	122 %
NB	16 256	17 657	20 921	20 042	18 249	13 703	13 298	13 060	12 426	76 %
NL	9 549	8 637	9 242	10 521	9 996	11 020	11 144	10 943	11 091	116 %
NS	19 602	19 084	22 319	23 153	20 423	16 735	16 178	16 775	16 223	83 %
NT	1 787	2 106	1 537	1 630	1 420	1 738	1 319	1 417	1 377	77 %
NU**			527	584	598	637	748	747	733	139 %
ON	180 048	180 698	209 698	205 679	174 292	162 874	157 594	163 437	163 233	91 %
PE	1 866	1 848	2 106	2 042	1 945	1 656	1 743	1 728	1 756	94 %
QC	86 371	85 418	86 512	87 574	80 476	79 137	81 164	82 501	83 698	97 %
SK	43 327	58 995	66 197	67 838	68 323	76 201	75 992	76 214	74 835	173 %
YK	550	580	534	568	647	529	564	645	690	126 %
Canada	601 524	656 297	733 511	738 717	702 803	723 094	716 090	728 475	730 245	121 %
NB†	2.70 %	2.69 %	2.85 %	2.71 %	2.60 %	1.89 %	1.86 %	1.79 %	1.70 %	
World	32 645 910	33 703 460	35 607 730	40 300 030	44 758 580	46 760 470	47 990 470	48 939 710		150 %
Canada‡	1.84 %	1.95 %	2.06 %	1.83 %	1.57 %	1.55 %	1.49 %	1.49 %		

NOTES:

*Percentage change between 1990 emissions and 2019 emissions except for Nunavut, which is between 2000 and 2019 (*n.b.*, Nunavut's GHG emissions were included as part of the Northwest Territories in 1990 and 1995), and the World, which is between 1990 and 2018

**Nunavut's GHG emissions were included as part of the Northwest Territories in 1990 and 1995

†New Brunswick's emissions contribution to Canada's emissions

‡Canada's emissions contribution to the World's emissions

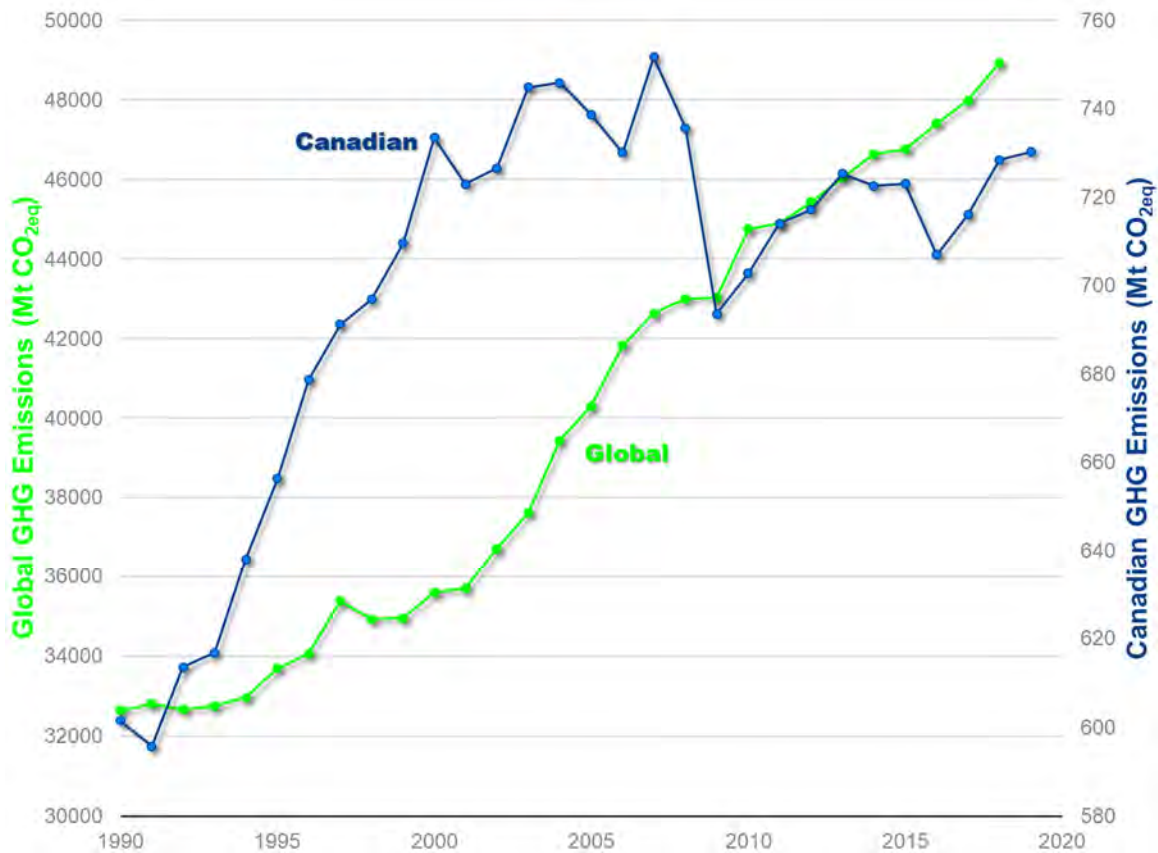

Figure 43. Global and Canadian annually reported greenhouse gas emissions in Megatonnes (Mt) of carbon dioxide equivalent units (CO_{2eq}).

Since 2004, several industrial facilities in New Brunswick have reported to the GHGRP. During that time, GHG emissions reporting in the Province have collectively decreased by 43 % from about 22 000 kt · yr⁻¹ CO_{2eq} in 2004 to ~ 12 400 kt · yr⁻¹ CO_{2eq} in 2019. Industrial emissions reductions, which are a significant amount of overall emissions, have resulted from the implementation of improved technology and the phasing out of coal-fired power generating stations (*i.e.*, NB Power’s Grand Lake Generating Station in 2010 and NB Power’s Dalhousie Generating Station in 2012) [ECCC, 2021b].

Figure 44 shows the total CO_{2eq} emissions from 20 industrial facilities in New Brunswick that reported to the GHGRP between 2014 and 2018. The four largest contributors to total carbon dioxide equivalent emissions, which represent > 80 % of the reported emissions, are NB Power’s Belledune Generating Station, the Irving Oil Refinery, NB Power’s Coleson Cove Generating Station, and Bayside Power. Belledune, which is the second largest industrial facility in the Province, is a coal-fired electricity generating station that is scheduled to be shuttered in 2030 to meet the Federal Government’s initiative to mitigate climate change.

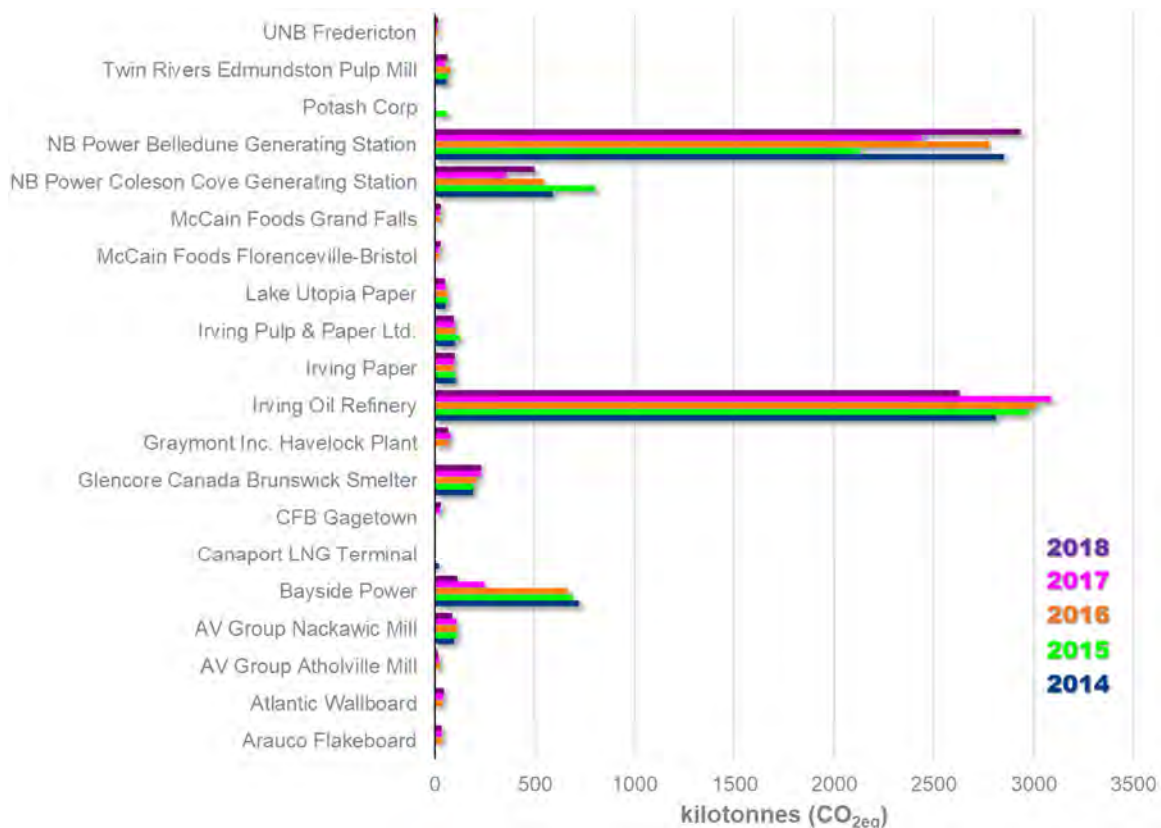

Figure 44. Reported total carbon dioxide equivalents ($\text{CO}_{2\text{eq}}$), in kilotonnes, for New Brunswick facilities that reported to the Greenhouse Gas Emissions Reporting Program between 2014 and 2018.

3.1.3 Sound Levels

Saint John has pockets of heavy industrialized areas (e.g., the Irving Oil Refinery, the East Saint John Terminals, Saint John Harbour, the IPP Mill, etc.). Dense urban residential neighbourhoods are found within the older parts of the City that surround the industrialized areas (i.e., people wanted to be close to their places of work). The Mill is surrounded by various types of public and private infrastructure, such as major highways and thoroughfares and railways. Collectively, these activities and uses result in ambient sound levels typical of an industrial and urban setting.

3.1.4 Topography

Saint John is located in the south-central portion of New Brunswick along the north shore of the Bay of Fundy at the mouth of the Saint John River. The Mill is located on the western bank of a narrow steep-sided gorge (i.e., ~ 120 m wide with 20 m high rock banks) where the River enters Saint John Harbour. Strong tides within the Bay cause the water flow within the Saint John River to reverse direction twice a day, which gives the gorge its name of Reversing Falls / Rapids. Regional topography is hilly. Two coastal mountain ranges, the St. Croix Highlands from the west and the Caledonia Highlands to the east, converge as they run along the Bay of Fundy (i.e., the two ranges are divided by the Saint John River). Locally, Milford is fairly rugged ridge and valley topography (Figure 45).



Figure 45. Aerial photograph, circa 2021, showing the general topography at the Reversing Falls Mill at the mouth of the Saint John River in Saint John, New Brunswick.

Elevations in the Milford area range from ~ 0 m (*i.e.*, at the lower end of the Reversing Falls) to ~ 45 m (*i.e.*, at the Milford Memorial Community Centre). Generally, slopes range

from about 2 % to 15 %, but can be considerably greater along the banks of the Saint John River. Bedrock outcroppings and bedrock bluffs are regionally prominent.

The Mill exists in a topographically low area on the banks of the Saint John River. Elevations on the Mill site range from about 0 m to 30 m (Figure 45). The Project site exists at ground elevations around 10 m and is bordered by existing access roads to the south and west. To the east, the Project site is bordered by existing Mill buildings and the Irving Tissue plant. To the north, the Project site is bounded by the NB Southern Railway Line at an elevation of about 30 m.

3.1.5 Hydrology

The City of Saint John is located within the 55 400 km² Saint John River watershed. The Mill is located on the western bank of the Wolastoq / W'alustuk (*i.e.*, the Maliseet name for the Saint John River, which means Bountiful Beautiful River) at Reversing Falls. Review of the watercourse and wetland mapping from the NBDELG's GeoNB online GIS tool shows that there are no mapped streams or wetlands on the Mill site (Figure 46). Ground-truthing by Fundy Engineering in October 2013 confirmed that there are no onsite watercourses or wetlands. Although much of the Saint John River valley experiences some flooding during the spring freshet, the Mill site is not prone to flooding; however, unprecedented flooding during the 2018 spring freshet did pose a risk to Mill infrastructure, which is being mitigated through the raising of the River's banks around Lee Cove. Site drainage is northeast towards the Saint John River.

Since 1966, Environment and Climate Change Canada has operated a continuous recording hydrometric station on the Saint John River at Saint John (01AP005) [ECCC, 2021c]. The station monitors water levels at the mouth of the Saint John River (*n.b.*, it is located 1 km upstream of the Mill on the eastern bank of the River). Water level data from 1966 through 2019 show a fairly standard hydrograph (Figure 47); water levels rise and fall in response to precipitation events and tides as the station is located near the mouth of the river. Large peaks are observed in April / May during the spring freshet. The highest water level recorded at the station during the spring freshet prior to 2018 was 5.31 m in 1971 (Table 21). The River set a new peak record on 7 May 2018 when it crested at 5.73 m.

The 673 km long Saint John River yields a mean discharge through the Reversing Falls of about 990 m³ · s⁻¹ [Hughes Clarke, 2000]. The peak discharge during the spring freshet is up to 6 800 m³ · s⁻¹.

The mouth of the Saint John River is also affected by the tides of the Bay of Fundy, which experiences the World's highest tides. The semi-diurnal tides, on a cycle of about 12.42 hours, are generally in the range of 6.49 m. The tides within the Bay of Fundy vary based on tidal constituent (*e.g.*, moon and sun gravitational effects, bathymetry, weather, *etc.*). Tidal levels have been measured within Saint John Harbour since May 1896. As noted in Table 22, the mean water level within the Harbour is 4.38 m above chart datum and the mean tidal range is 6.49 m. The extreme high water level measured at Saint John was 9.14 m above chart datum, which has occurred twice since 1896; on 2 February 1976 (*i.e.*, the *Groundhog Day Gale*) and on 10 January 1997. Conversely, the extreme low water level was 0.40 m below chart datum and occurred on 26 January 1944. The extreme tidal range is 9.54 m.



Figure 46. Aerial photograph, circa 2021, showing regulated watercourses and wetlands in the vicinity of the Reversing Falls Mill at the mouth of the Saint John River in Saint John, New Brunswick.

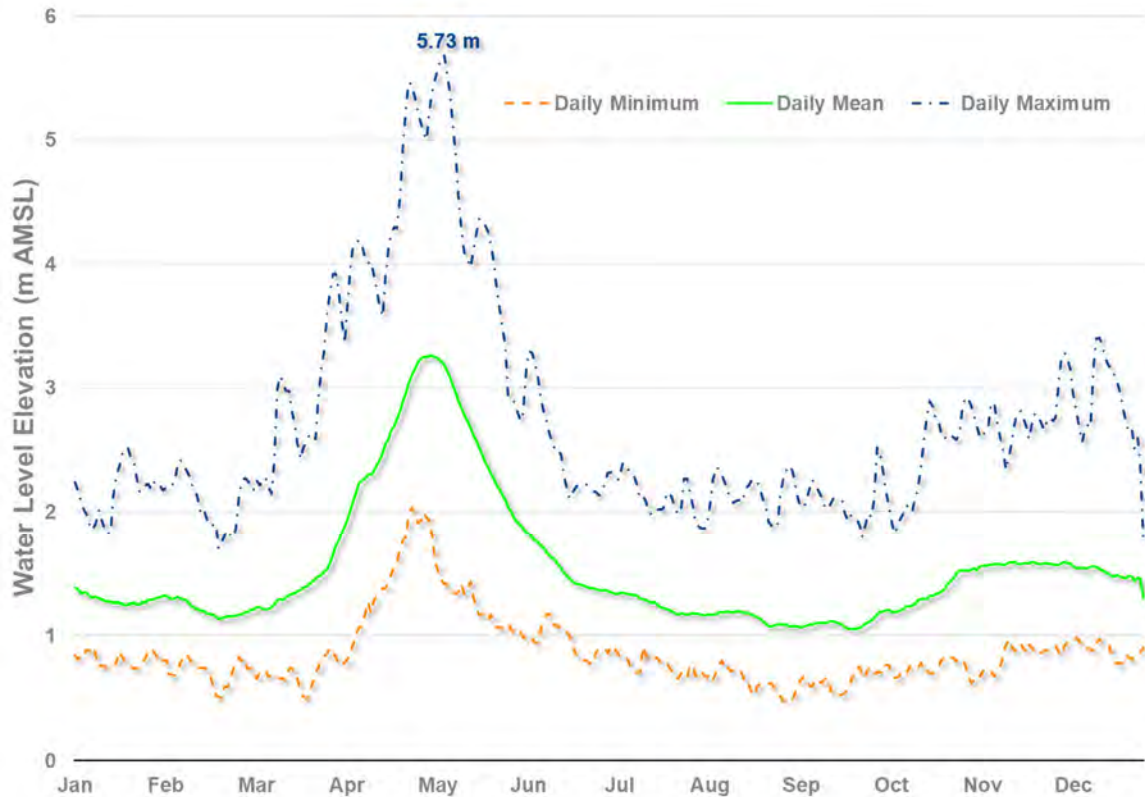

Figure 47. Minimum, mean, and maximum daily water level measurements as recorded at Environment Canada's hydrometric station on the Saint John River at Saint John, New Brunswick between 1 January 1966 and 31 December 2019.

Table 21. River stages at Saint John, New Brunswick for the Saint John River.

River Stage	Water Level (m)
Ordinary high water mark	3.69
Flood stage	4.20
1973 maximum level	5.31
2018 maximum level	5.73

Table 22. Tide levels, relative to chart datum, for Saint John Harbour, New Brunswick.

Tide	Relative to Chart Datum (m)
Extreme high water level	9.14
Large tide higher high water level	8.99
Mean tide higher high water level	7.59
Mean water level	4.38
Mean tide lower water level	1.10
Large tide lower low water level	- 0.09
Extreme low water level	- 0.40

3.1.6 Geology

3.1.6.1 Bedrock

The Reversing Falls Mill lies within the Caledonia Highland physiographic region of New Brunswick [Rampton *et al.*, 1984]. The Caledonia Zone is underlain by a Middle Proterozoic quartzite-carbonate sequence and a succession of Late Proterozoic volcanic and associated intrusive rocks. A Cambrian to Early Ordovician platformal sequence containing a distinctive Acado-Baltic trilobite fauna unconformity overlies Precambrian rocks. The Caledonia Zone is generally considered to represent a crustal fragment rifted from the margin of Gondwana during opening of the Early Paleozoic Iapetus Ocean.

Bedrock geology of the local area is described in Table 23 and shown in Figure 48. Underlying the majority of the Mill site are metamorphic and igneous rocks from the following four formations: Ashburn; Brookville Gneiss; Fairville Granite; and an unnamed formation of deformed granitoid rocks [Johnson *et al.*, 2005]. Rocks of the formations are typically Cambrian (*i.e.*, 505 million years ago (mya) to 545 mya) and Neoproterozoic in age (*i.e.*, 545 mya to 1 000 mya). Bedrock exposure in the area is predominant.

Table 23. Descriptions of the bedrock geology in the vicinity of the Reversing Falls Mill at the mouth of the Saint John River in Saint John, New Brunswick.

Code	Age	Group	Formation	Description
ZAS _{mb}	Middle Neoproterozoic	Green Head	Ashburn	White to grey and light green, generally banded and locally stromatolitic marble; black to brown pelite; massive spotted hornfels; white to grey fine-grained quartzite; minor marble-pebble conglomerate and mica schist
ZBK _{gn}	Middle Neoproterozoic	New River Plutonic Suite	Brookville Gneiss	Dark grey to pinkish grey fine-grained to medium-grained, banded, and locally magmatitic paragneiss with minor calc-silicate, marble, or quartzite layers; grey medium-grained granodioritic to tonalitic orthogneiss with locally abundant biotite schlieren and amphibolite; the gneisses are locally intruded granodiorite, pegmatite, and diabase
ZF _{fl}	Neoproterozoic / Cambrian	Golden Grove Plutonic Suite	Fairville Granite	Pink to orange coarse-grained granite gradational to granodiorite; commonly feldspar megacrystic and elongate enclaves of fine-grained dioritic rocks
Z€T _{lvs}	Neoproterozoic / Cambrian	Lorneville	Taylor's Island	Epidotized and hematized basaltic breccia; red and minor green sandstone, siltstone, and conglomerate; minor red felsic lithic tuff and quartzite
Z€ _{ii}	Neoproterozoic / Cambrian	Golden Grove Plutonic Suite	Deformed Granitoid Rocks	Grey strongly deformed monzogranite to granodiorite with augen of feldspar and quartz
€ _{lmi}	Neoproterozoic / Cambrian	Golden Grove Plutonic Suite	Indiantown Gabbro	Green to grey medium- to coarse-grained gabbro
€O _{SJc}	Cambrian to early Ordovician	Saint John	Ratcliffe Brook, Glen Falls, Hanford Brook, Forest Hills, Kings Square, Silver Falls, Reversing Falls	Red beds; white quartzite and black sandstone; grey sandstone and shale; grey to black shale and impure limestone; grey fine-grained sandstone and micaceous shale and siltstone; black shale and fine-grained sandstone; black carbonaceous shale
€R _{Pii}	Neoproterozoic / Cambrian	Golden Grove Plutonic Suite	Rockwood Park Granodiorite	Grey medium-grained granodiorite gradational to tonalite; abundant ellipsoidal dioritic enclaves

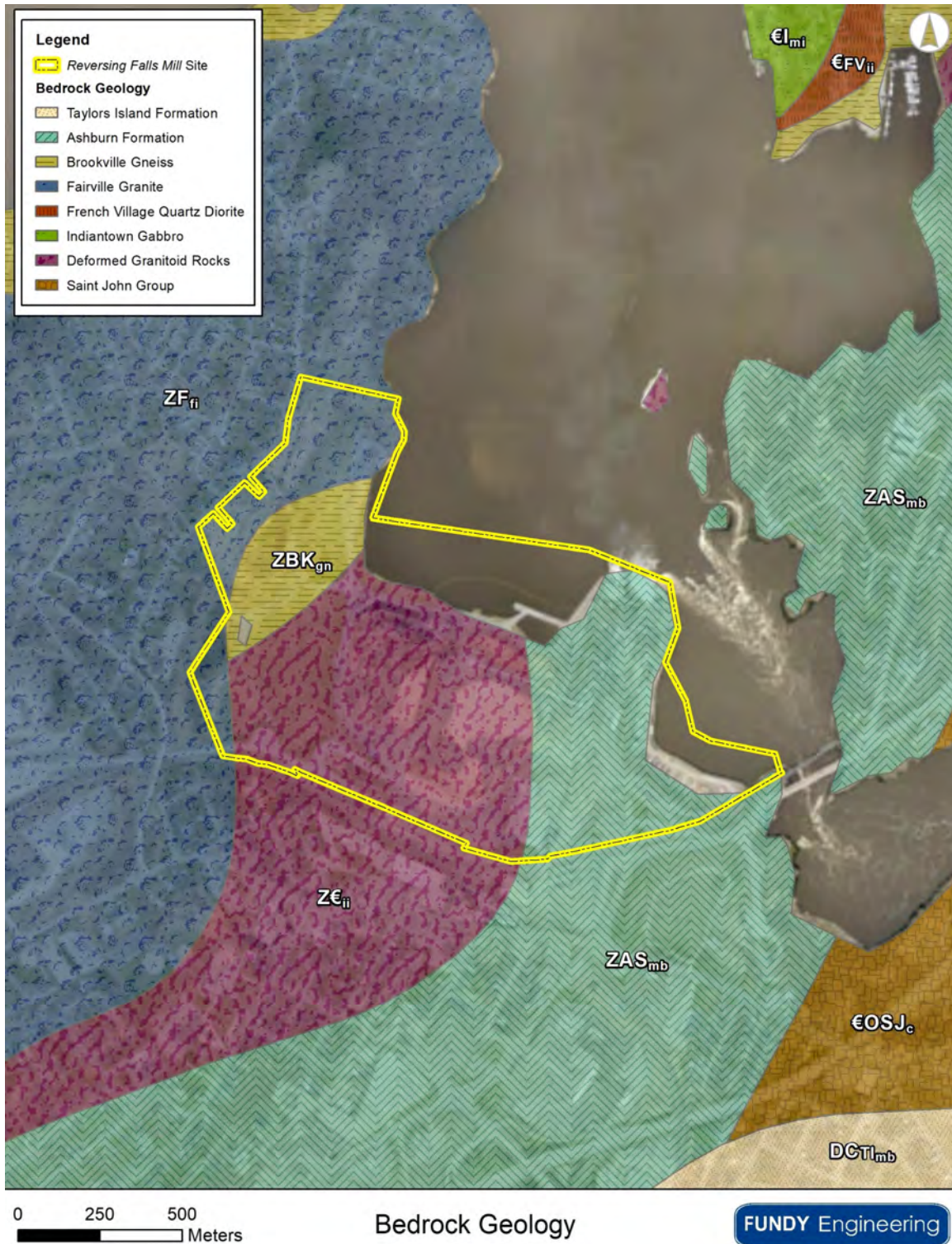

Figure 48. Bedrock geology in the vicinity of the Reversing Falls Mill at the mouth of the Saint John River in Saint John, New Brunswick. See text for bedrock geology descriptions.

3.1.6.2 Surficial

Surficial geology of the local area is described in Table 24 and shown in Figure 49. The Milford area is generally overlain by Late Wisconsinan and / or early Holocene sediments [Rampton, 1984]. Those blankets and veneers of marine sediments are typically 0.5 m to 3 m thick and are generally comprised of sand, silt, and some gravel and clay. The materials were deposited in shallow marine water, locally deep, which submerged coastal areas and sections of many valleys during and following Late Wisconsinan deglaciation.

Table 24. Descriptions of the surficial geology in the vicinity of the Reversing Falls Mill at the mouth of the Saint John River in Saint John, New Brunswick.

Code	Age	Description
aMb3	Late Wisconsinan	Morainal blankets generally 0.5 m to 3 m thick that are comprised typically of loamy lodgement till, minor ablation till, silt, sand, gravel, and rubble; the till is mainly stony with more than 35 % of clasts pebble-sized and larger; the sediments were deposited directly by Late Wisconsinan ice or with minor reworking by water
aMv3	Late Wisconsinan	Morainal veneer is discontinuous over rock that is < 0.5 m thick and comprised typically of loamy lodgement till, minor ablation till, silt, sand, gravel, and rubble; the till is mainly stony with more than 35 % of clasts pebble-sized and larger; the sediments were deposited directly by Late Wisconsinan ice or with minor reworking by water
R	Pre-Quaternary	Rock of various lithologies and all ages; generally weathered and partially disintegrated, glacially moulded surfaces; few localities show glacially scoured and polished surfaces
Wb	Late Wisconsinan and / or Early Holocene	Marine sediments of sand, silt, gravel, and clay; deposited in shallow marine water, locally deep, which submerged coastal areas and sections of many valleys during and following Late Wisconsinan deglaciation; blankets and plains of sand, silt, some gravel and clay are generally 0.5 m to 3 m thick

A geotechnical study was completed by Stantec in early 2021 for the area where the ETF will be constructed (*i.e.*, refer to Appendix VI). The results showed sands and clays up to about 3.5 m thick atop bedrock in topographically high areas where the indirect air coolers, primary clarifier, and MBBRs will be located. Thick layers of historical Mill organic materials (*i.e.*, up to 11 m of bark, wood chips, and logs) were found atop bedrock in the topographically low areas where the process building and EQ tank will be located.

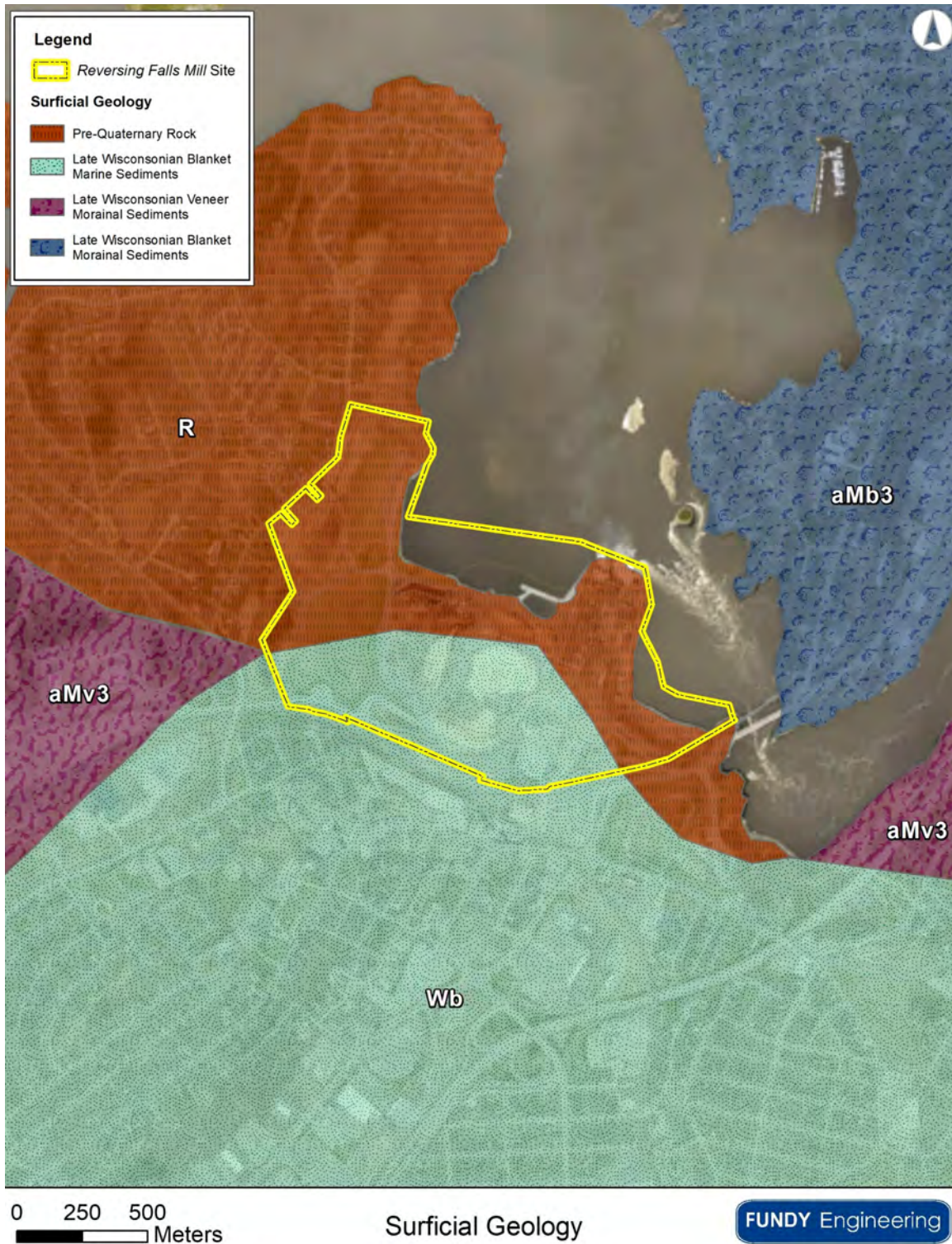

Figure 49. Surficial geology in the vicinity of the Reversing Falls Mill at the mouth of the Saint John River in Saint John, New Brunswick. See text for surficial geology descriptions.

3.1.7 Hydrogeology

Approximately 64 % of New Brunswick's population is reliant on groundwater for supplying domestic freshwater [Natural Resources Canada, 2005]. Individual water well owners in the province depend on small aquifers, typically composed of thin glacial sand and gravel deposits, to supply their potable water. Regional groundwater availability maps exist for most of Canada and are generalizations of large quantities of data collected for a region [Natural Resources Canada, 2005]. In Saint John, aquifers are typically able to supply a flow rate $< 24 \text{ L} \cdot \text{min}^{-1}$ (Figure 50); however, localized groundwater availability can only be determined through onsite investigations.

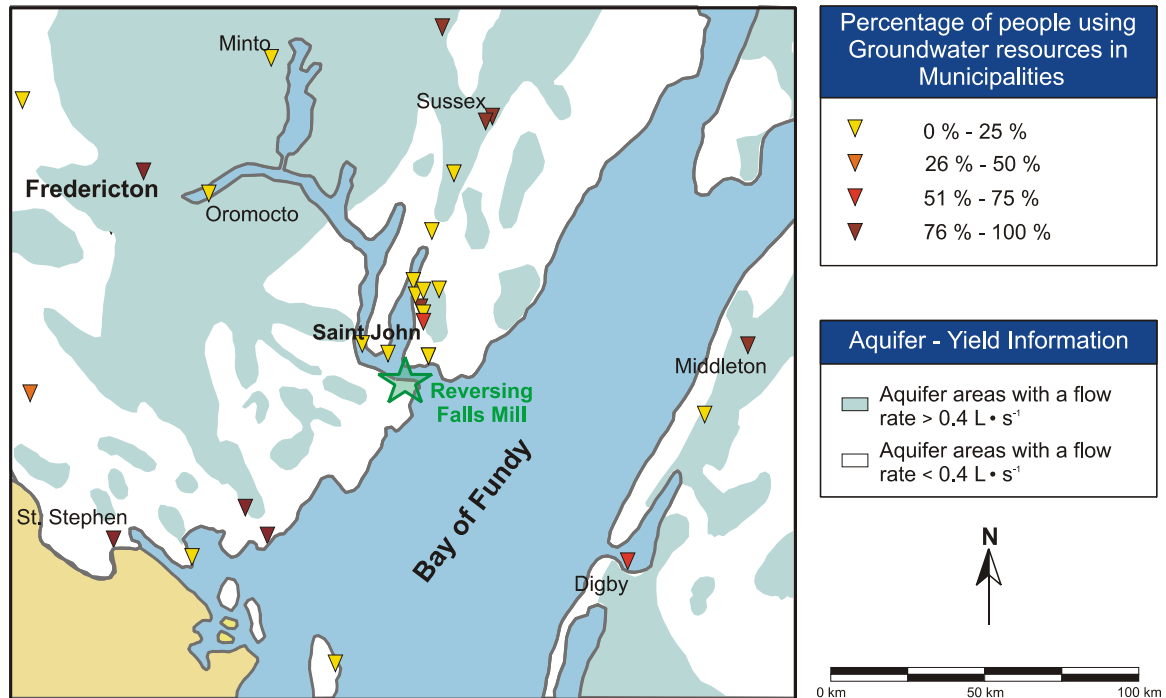

Figure 50. Groundwater availability map for Saint John, New Brunswick and the surrounding area.

Residential, commercial, and industrial properties in Milford and surrounding areas are mostly reliant on municipal water for supplying potable water and / or process water. Municipal water for residents in east Saint John is derived from the Loch Lomond reservoir, a surface water source. Municipal water for residents in west Saint John is derived either from the Loch Lomond reservoir or the South Bay Wellfield, a groundwater source. Untreated industrial water for east-side businesses is derived from Loch Lomond while those on the west-side is derived from the Spruce Lake Watershed, a surface water source.

A groundwater well records search was performed within a 1 km radius of the Mill site. The records search yielded nine well logs (*n.b.*, not all well logs provide all data assessed below, which is the reason *n* varies). The general location of those wells is shown in Figure 51. All of the wells are installed in a confined aquifer and Table 25 and Figure 52 provides a summary of the data obtained from the NBDELG's groundwater well database. For the complete data set, please refer to Appendix VII.

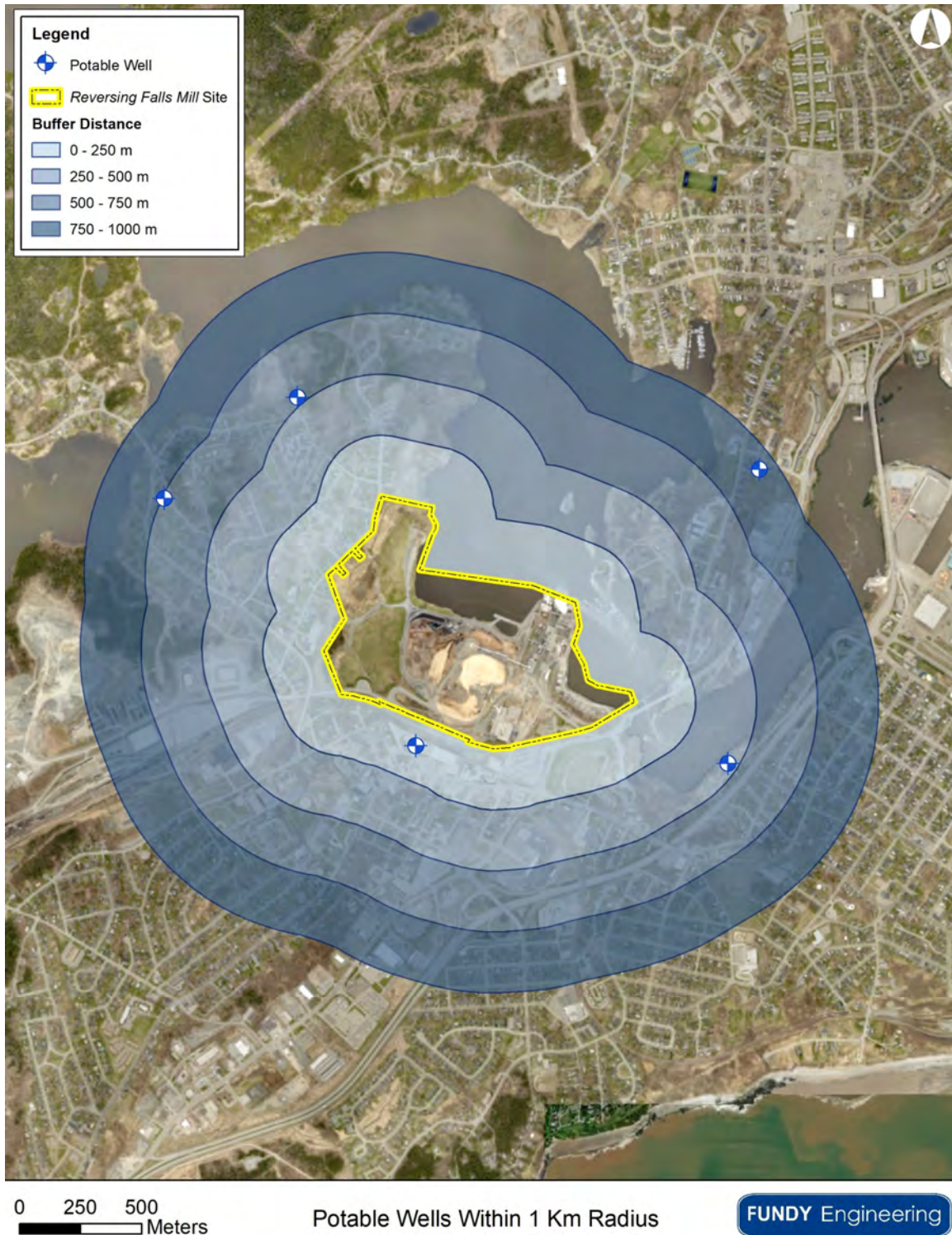

Figure 51. General location of the groundwater well records that were reviewed within 1 km radius of the Reversing Falls Mill at the mouth of the Saint John River in Saint John, New Brunswick.

Table 25. Summary of the groundwater well records within a 1 km radius of the Reversing Falls Mill at the mouth of the Saint John River in Saint John, New Brunswick.

Parameter*	n	Mean ± Std. Dev.	Min	Max
Well depth (m)	9	78.5 ± 34.52	36.9	121.9
Casing length (m)	9	38.6 ± 31.3	6.1	86.3
Bedrock depth (m)	7	25.0 ± 20.93	0.6	56.4
Safe yield (L · min ⁻¹)	9	277.6 ± 349.69	4.6	910.0
Static water level (m)	9	52.4 ± 52.12	0	121.9

Notes:

*As determined by the Water Well Driller(s) during installation

No water quality data were included in the NBDELG's groundwater well database.

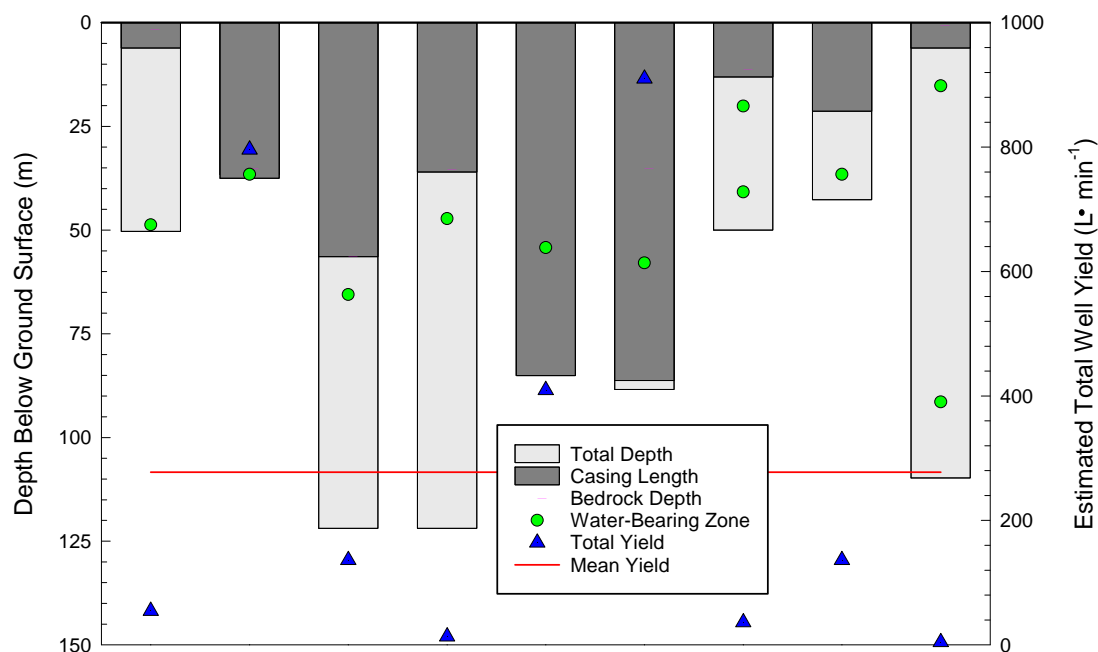

Figure 52. Compilation of the nine groundwater well records within 1 km radius of the Reversing Falls Mill at the mouth of the Saint John River in Saint John, New Brunswick.

3.1.8 Hydrography

The Mill exists at the mouth of the Saint John River. Locally, the confluence is known as Reversing Falls and is where the river runs through a narrow gorge and over a bedrock sill before entering Saint John Harbour [Metcalfe *et al.*, 1976]. The Bay of Fundy's semi-diurnal tides force the flow of water from the River to reverse for a short period of time when the tide is high. A series of underwater ledges create an intensely turbulent, jet-like flow through the narrow gorge and produces recirculating eddies upstream and downstream. The underwater bedrock sill / ledges can also pose a significant navigation hazard so vessels typically wait until a slack high tide to go through the Reversing Falls.

A portion of the hydrographic chart for Saint John to Grand Bay in the vicinity of the Mill (*i.e.*, Union Point) is shown in Figure 53. Depths in the centre of the channel for the portion

shown range from as deep as 47 m off of Lee Cove to as shallow as 3.7 m through the Reversing Falls. Figure 54 shows the bathymetry of the Saint John River extending from Pleasant Point upstream of the Mill to downstream just below the Harbour Bridge at the Navy Island Terminal in three dimensions.

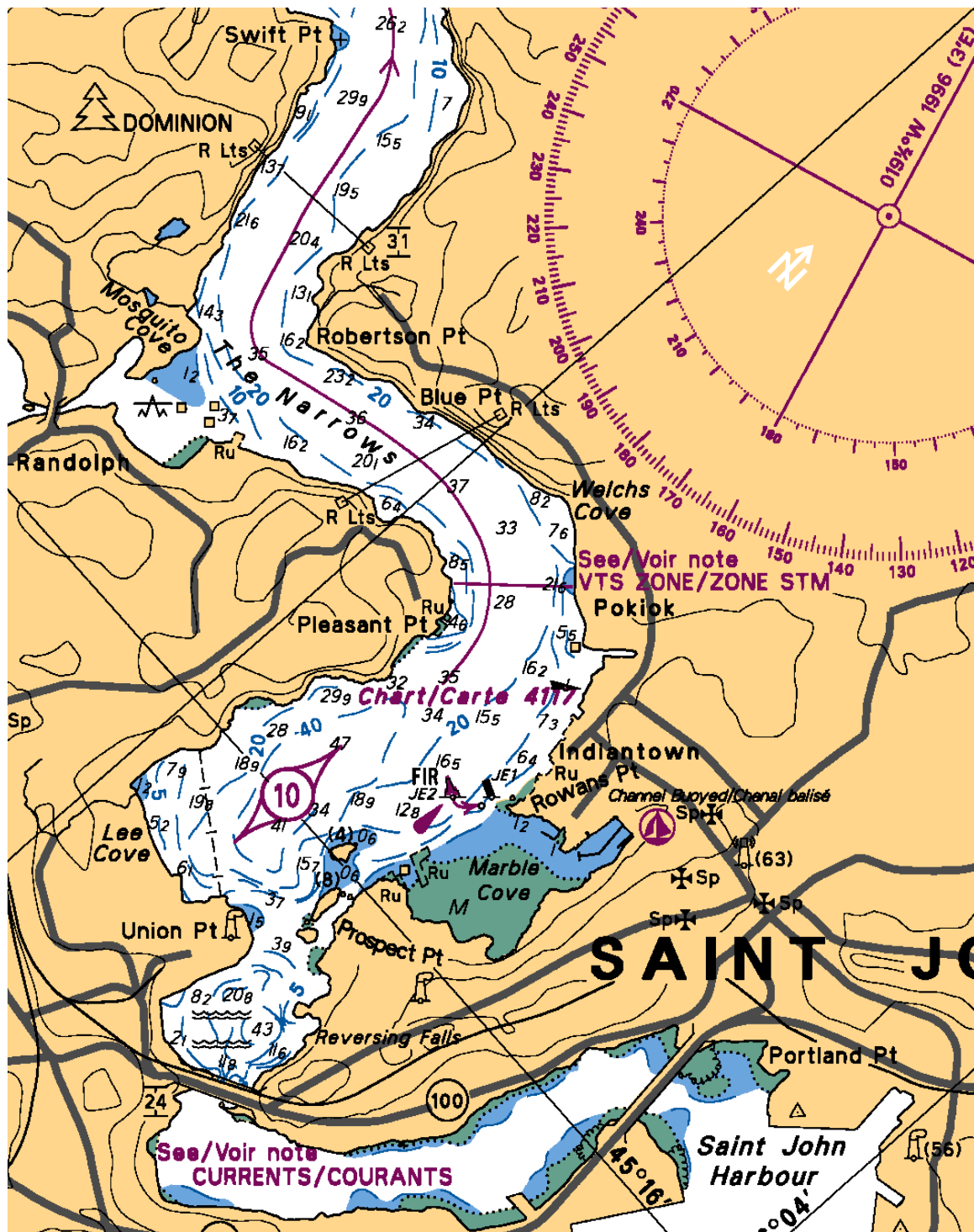

Figure 53. Portion of the Saint John to Grandy Bay, New Brunswick hydrographic chart 4141. Depths are in metres and Union Pt is the site of the Reversing Falls Mill.

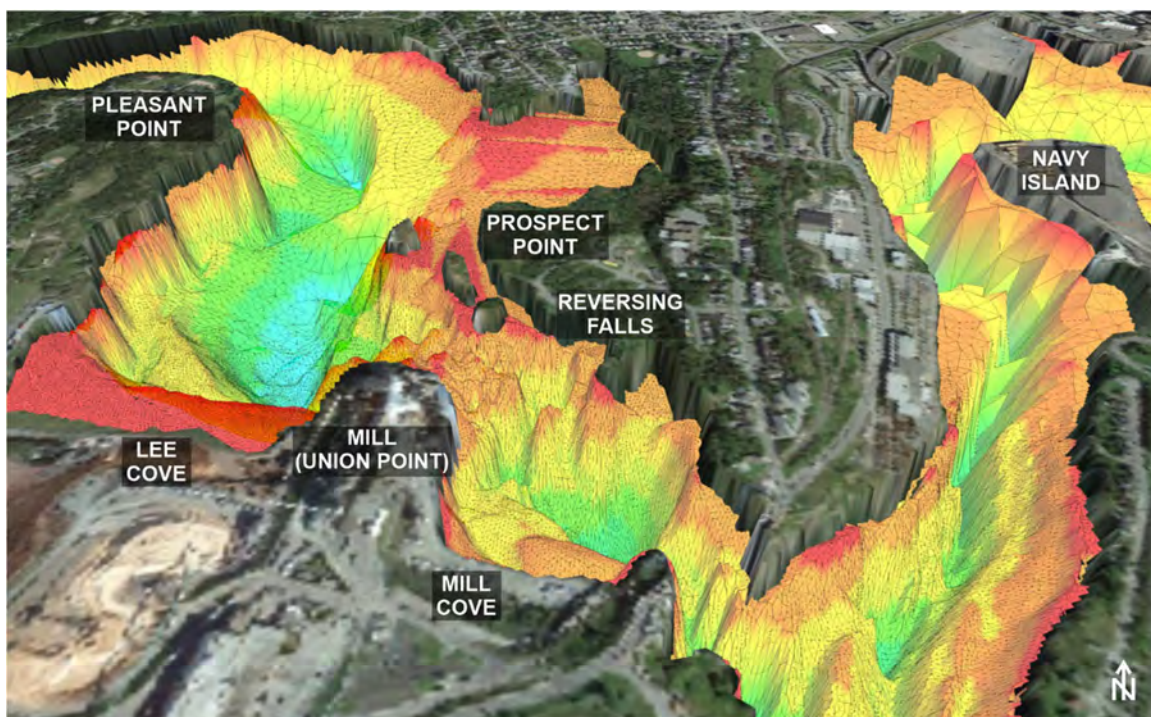

Figure 54. Bathymetry of the Saint John River in the vicinity of the Reversing Falls Mill in Saint John, New Brunswick. From Appendix XI.

3.2 BIOLOGICAL ENVIRONMENT

3.2.1 Federal Species At Risk

Federally listed species at risk that exist in New Brunswick and could potentially be impacted by the Project are noted in Table 26. Those terrestrial and aquatic species identified under the federal *Species At Risk Act* (fSARA) [S.C. 2002, c. 29] and by the Committee On Status of Endangered Wildlife In Canada (COSEWIC) as being at risk in New Brunswick are listed. Listing of a species in Table 26 does not indicate that it is either present or absent at the Project site. Presence and absence information is provided below. The order of risk level under the fSARA and by the COSEWIC is as follows: special concern; threatened; endangered; extirpated; and extinct.

Table 26. Terrestrial and aquatic flora and fauna listed as being species at risk under the fSARA and by the COSEWIC that could potentially be affected by the proposed Project at the Reversing Falls Mill in Saint John, New Brunswick.

Common Name	Scientific Name	fSARA Status	COSEWIC Status
<u>Vascular Plants, Mosses, and Lichens</u>			
Black foam lichen	<i>Anzia colpodes</i>	Threatened	Threatened
Blue felt lichen	<i>Degelia plumbea</i>	Special concern	Special concern
Vole ears lichen	<i>Erioderma mollissimum</i>	Endangered	Endangered
Boreal felt lichen	<i>Erioderma pedicellatum</i>	Endangered	Endangered
Prototype quillwort	<i>Isoetes prototypus</i>	Special concern	Special concern
Butternut	<i>Juglans cinerea</i>	Endangered	Endangered

Common Name	Scientific Name	fSARA Status	COSEWIC Status
Beach pinweed	<i>Lechea maritime</i>	Special concern	Special concern
Wrinkled shingle lichen	<i>Pannaria lurida</i>	Threatened	Threatened
Furbish's lousewort	<i>Pedicularis furishiae</i>	Endangered	Endangered
Eastern waterfan	<i>Peltigera hydrothyria</i>	Threatened	Threatened
Anticosti aster	<i>Symphyotrichum anticostense</i>	Threatened	Special concern
Gulf of St. Lawrence aster	<i>Symphyotrichum laurentianum</i>	Threatened	Threatened
Molluscs			
Dwarf wedgemussel	<i>Alasmidonta heterodon</i>	Extirpated	Extirpated
Brook floater	<i>Alasmidonta varicosa</i>	Special concern	Special concern
Yellow lampmussel	<i>Lampsilis cariosa</i>	Special concern	Special concern
Reptiles			
Snapping turtle	<i>Chelydra serpentina</i>	Special concern	Special concern
Eastern painted turtle	<i>Chrysemys picta</i>	Special concern	Special concern
Wood turtle	<i>Glyptemys insculpta</i>	Threatened	Threatened
Birds			
Eastern whip-poor-will	<i>Anrostomus vociferus</i>	Threatened	Threatened
Short-eared owl	<i>Asio flammeus</i>	Special concern	Threatened
Barrow's goldeneye	<i>Bucephala islandica</i>	Special concern	Special concern
Red knot <i>rufa</i> subspecies	<i>Calidris canutus rufa</i>	Endangered	Endangered
Canada warbler	<i>Cardellina canadensis</i>	Threatened	Special concern
Bicknell's thrush	<i>Catharus bicknelli</i>	Threatened	Threatened
Chimney swift	<i>Chaetura pelagica</i>	Threatened	Threatened
Piping plover <i>melodus</i> subspecies	<i>Charadrius melodus melodus</i>	Endangered	Endangered
Common nighthawk	<i>Chordeiles minor</i>	Threatened	Special concern
Evening grosbeak	<i>Coccothraustes vespertinus</i>	Special concern	Special concern
Olive-sided flycatcher	<i>Contopus cooperi</i>	Threatened	Threatened
Eastern wood-pewee	<i>Contopus virens</i>	Special concern	Special concern
Yellow rail	<i>Coturnicops noveboracensis</i>	Special concern	Special concern
Bobolink	<i>Dolichonyx oryzivorus</i>	Threatened	Threatened
Rusty blackbird	<i>Euphagus carolinus</i>	Special concern	Special concern
Barn swallow	<i>Hirundo rustica</i>	Threatened	Special concern
Harlequin duck	<i>Histrionicus histrionicus</i>	Special concern	Special concern
Wood thrush	<i>Hylocichla mustelina</i>	Threatened	Threatened
Least bittern	<i>Ixobrychus exilis</i>	Threatened	Threatened
Eskimo curlew	<i>Numenius borealis</i>	Endangered	Endangered
Red-necked phalarope	<i>Phalaropus lobatus</i>	Special concern	Special concern
Horned grebe (Magdalen Islands Pop.)	<i>Podiceps auritus</i>	Endangered	Endangered
Bank swallow	<i>Riparia riparia</i>	Threatened	Threatened
Roseate tern	<i>Sterna dougallii</i>	Endangered	Endangered
Eastern meadowlark	<i>Sturnella magna</i>	Threatened	Threatened
Buff-breasted sandpiper	<i>Tryngites subruficollis</i>	Special Concern	Special Concern

Common Name	Scientific Name	fSARA Status	COSEWIC Status
<u>Arthropods</u>			
Gypsy cuckoo bumble bee	<i>Bombus bohemicus</i>	Endangered	Endangered
Yellow-banded bumble bee	<i>Bombus terricola</i>	Special concern	Special concern
Cobblestone tiger beetle	<i>Cicindela marginipennis</i>	Endangered	Endangered
Maritime ringlet	<i>Coenonympha nipsisquit</i>	Endangered	Endangered
Monarch butterfly	<i>Danaus plexippus</i>	Special concern	Special concern
Skillet clubtail	<i>Gomphus ventricosus</i>	Endangered	Endangered
Pygmy snaketail	<i>Ophiogomphus howei</i>	Special concern	Special concern
<u>Fishes</u>			
Shortnose sturgeon	<i>Acipenser brevirostrum</i>	Special concern	Special concern
White shark	<i>Carcharodon carcharias</i>	Endangered	Endangered
Rainbow smelt (Lake Utopia)	<i>Osmerus mordax</i>	Endangered	Endangered
Atlantic salmon (IBOF pop.)	<i>Salmo salar</i>	Endangered	Endangered
<u>Terrestrial Mammals</u>			
Little brown bat	<i>Myotis lucifugus</i>	Endangered	Endangered
Northern bat	<i>Myotis septentrionalis</i>	Endangered	Endangered
Tri-colored bat	<i>Perimyotis subflavus</i>	Endangered	Endangered

The Atlantic Canada Conservation Data Centre (ACCDC) databases were queried for known observation data of federally protected species within a 5 km radius of the Project site (*i.e.*, refer to Appendix VIII). According to the ACCDC data, 13 species listed under the fSARA and by the COSEWIC have been observed (Figure 55).

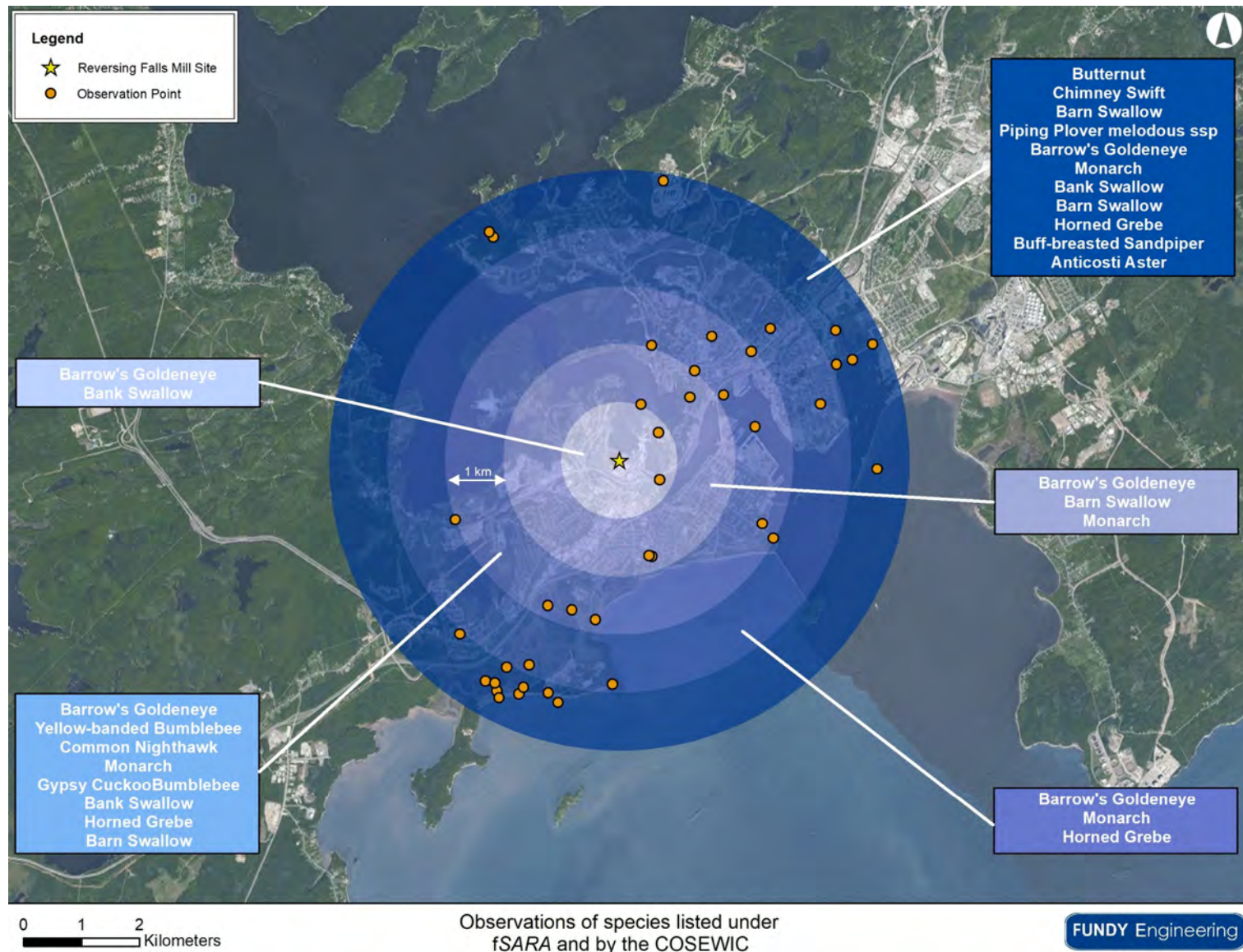

Figure 55. Map showing the recorded observations of species listed under the fSARA and by the COSEWIC within a 5 km radius of the Reversing Falls Mill in Saint John, New Brunswick. Data obtained from the ACCDC.

3.2.1.1 Snapshots of Federal Species At Risk Locally Present

Detailed information provided below on the protected species was obtained from the species profiles on the fSARA [SARA, 2021] and COSEWIC [COSEWIC, 2021] websites.

The Anticosti aster (Figure 56), which is ranked as threatened under the fSARA and as a species of special concern by the COSEWIC (Table 26), is a 10 cm to 75 cm tall, herbaceous plant that spreads by long rhizomes to form loose clonal colonies. It originated by hybridization of the New York aster and the rush aster. The plants have long-stalked flower heads composed of purple ray (*i.e.*, petal-like) florets and yellow disk florets. Its leaves are stiff, narrow, and somewhat leathery in texture, often arched, and have smooth or minutely toothed margins. It is a ranked species because it is a rare regional endemic species of postglacial origin that grows in association with many other plant species of conservation concern within regionally significant calcareous river shore communities.

The bank swallow (Figure 56) is a small (*i.e.*, 12 cm to 14 cm long with a 25 cm to 29 cm wingspan) slender insectivorous songbird that is highly social at all times of the year and is conspicuous at colonial breeding sites. At those sites, it excavates nesting burrows about 75 cm long in eroding vertical banks, such as riverbanks, lake and ocean bluffs, aggregate pits, road cuts, and stockpiles of soil, using its conical bill, feet, and wings. It is ranked as threatened under the fSARA and by the COSEWIC (Table 26) because of the severe long-term population decline over the last 40 years resulting primarily from the loss of breeding and foraging habitat. The bank swallow has a white underbelly and is brown on top. It has a dark band across the chest that extends down the middle of the chest. It can be distinguished in flight from other swallows by its quick, erratic wing beats and its almost constant buzzy, chattering vocalizations.

The barn swallow (Figure 56) is the most widespread swallow species in the world. The population of over 190 million individuals globally is considered stable [BirdLife, 2014]. Because there have been considerable declines in the presence for the past several decades, the barn swallow is listed as threatened under the fSARA and as a species of special concern by the COSEWIC (Table 26). It is a distinctive passerine that has blue upperparts, a long, deeply forked tail that is curved, and pointed wings. This 17 cm to 19 cm long bird is commonly found in open areas with low vegetation, such as pasture, meadows, and farmland. They build a cup nest from mud pellets in barns or other similar structures and feed on insects caught while in flight.

Barrow's Goldeneye (Figure 56) is ranked as a species of special concern under the fSARA and by the COSEWIC (Table 26). It is a medium-sized monogamous diving duck that breeds and winters primarily in Canada. About 400 of these birds over-winter in Atlantic Canada. They breed in tree cavities and rock crevices and their nests are usually placed within 1 km to 2 km from water and between 2 m and 15 m above the ground. During the breeding season it feeds on aquatic insects and crustaceans of inland waters. During winter, they are partial to coastal waters where they feed on molluscs and crustaceans.

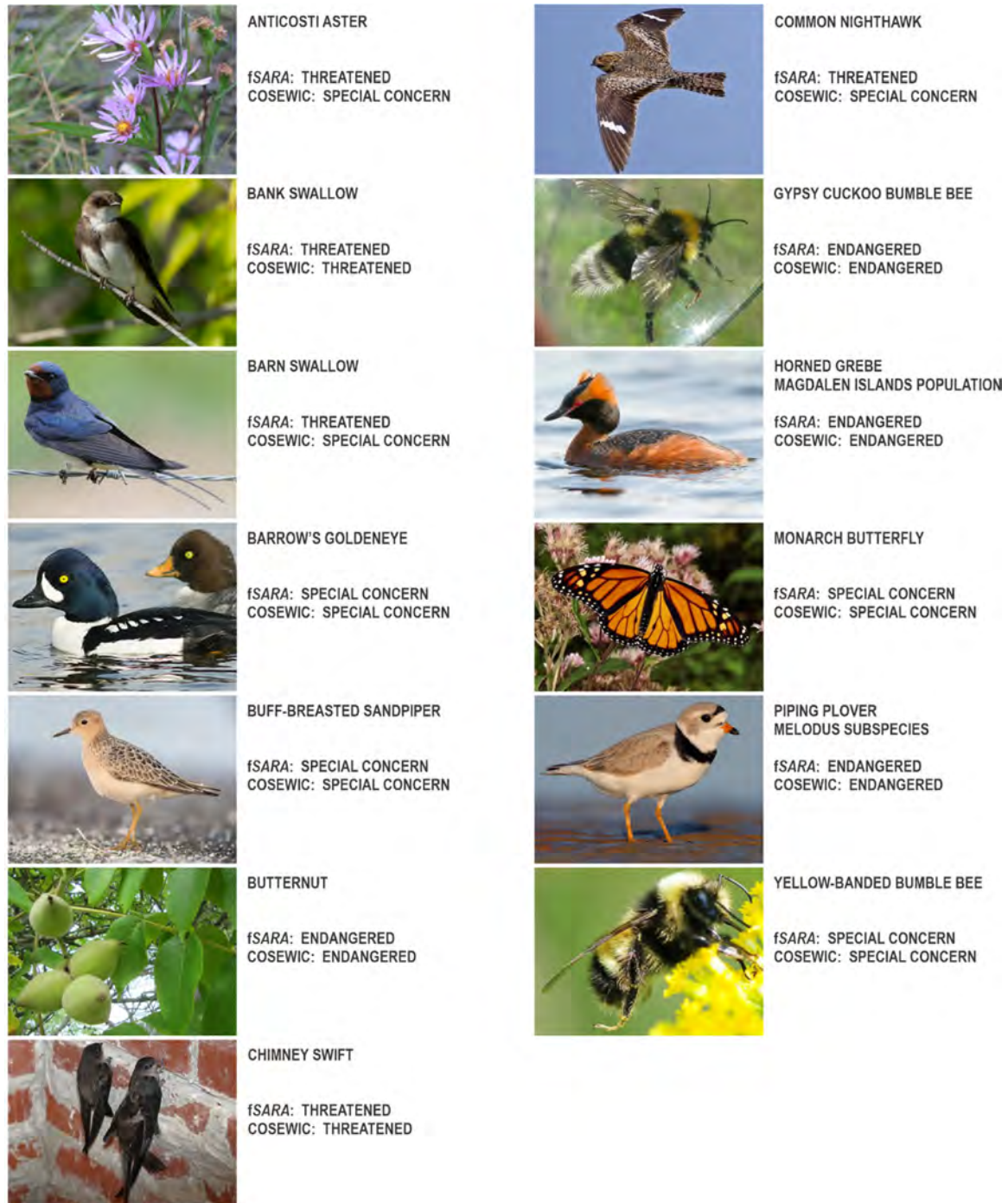

Figure 56. Photographs of species listed under the fSARA and by the COSEWIC that have been observed within a 5 km radius of the Reversing Falls Mill in Saint John, New Brunswick.

Buff-breasted sandpipers are small (*i.e.*, 18 to 20 cm long), delicately built shorebirds that have a fairly long neck, a rounded head like a dove, and a large eye (Figure 56). Their dark bills, which are no longer than their head, are slender and short for a sandpiper. Overall, they are buff with fine black streaks on the crown and dark centers to the back and upperwing feathers, giving a neat, scaly appearance. They nest on dry tundra

of the high arctic and are typically observed in dry, grassy habitats such as farm fields. They overwinter in grazed pastureland of southeastern South America. It was once common and perhaps even abundant, but intensive hunting led to their sharp decline to the point in the 1920s when they were thought to be on the brink of extinction. Since then, hunting them has been banned, but their specialized grassland habitat is under threat. Therefore, it is ranked as a species of special concern under the fSARA and by the COSEWIC (Table 26).

The butternut is a small to medium-sized tree with a broad and irregularly shaped crown that is rarely more than 30 m tall and 90 cm in diameter (Figure 56). This tree is mainly encountered as a minor component of deciduous stands, but large pure populations do exist on certain floodplains. It grows best in rich, fertile, moist, and well-drained soils often found along streams. In New Brunswick, it is estimated that there are only between 7 000 and 17 000 individuals. This has prompted the butternut to be ranked as endangered under the fSARA and by the COSEWIC (Table 26).

The chimney swift is a medium-sized (*i.e.*, 12 cm to 15 cm), sooty gray bird with very long, slender wings and very short legs. There are no subspecies of the chimney swift, but like all swifts, it is incapable of perching and can only cling vertically to surfaces (Figure 56). They build nests of twigs stuck together with saliva, in chimneys and other vertical surfaces in dim, enclosed areas including air vents, wells, hollow trees, and caves. They forage overall urban and suburban areas, rivers, lakes, forest, and fields in search of flying insects. Although the global population of chimney swifts is relatively healthy, they have been impacted in Atlantic Canada due to severe storm events and the reduction in nesting habitat (*i.e.*, chimneys are not as prevalent as they once were). This has caused them to be listed as threatened under the fSARA and by the COSEWIC (Table 26).

The common nighthawk (Figure 56), a medium-sized bird with long, narrow, pointed wings and a slightly notched long tail, is ranked as a threatened species under the fSARA and as a species of special concern by the COSEWIC (Table 26). While in flight, their distinguishing feature is a wide white stripe across the long feathers at the edge of their wings. They nest in a wide variety of open, vegetation-free habitats, including dunes, beaches, recently harvested forests, burnt-over areas, logged areas, rocky outcrops, rocky barrens, grasslands, pastures, peat bogs, marshes, lakeshores, and river banks. They are also known to inhabit mixed and coniferous forests. Causes of population decline are unknown, but it may be partly attributed to the decline of their main food source (*i.e.*, insects).

The gypsy cuckoo (Figure 56) is a medium-sized bumble bee (*i.e.*, 12 mm to 18 mm long) that is ranked as endangered under the fSARA and by the COSEWIC (Table 26). It has a white-tipped abdomen. Unlike most bumble bees, this bee lacks pollen baskets on their hind legs. This is because they do not bring pollen back to their colony. They also do not produce workers as they are a parasite bee and take over existing colonies of other bumble bees. They occur in a diversity of habitats such as open meadows, urban areas, and woodlands. The decline in their host species on which they depend, the use of pesticides, habitat loss, climate change, and pathogens introduced from managed bee colonies are the primary reasons for their sharp decline and the reason they are ranked as endangered.

The Magdalen Island's population of the horned grebe (Figure 56) is listed as endangered under the fSARA and by the COSEWIC (Table 26). It is a small (*i.e.*, 31 cm to 38 cm long)

duck-like waterbird that is not commonly observed in New Brunswick. Horned grebes generally nest in freshwater and occasionally in brackish water on small permanent or semi-permanent ponds, but it also uses marshes and shallow bays on lake borders. They generally winter in marine habitats, mainly estuaries and bays. The horned grebes' diet consists primarily of aquatic insects and fish in the summer and fish, crustaceans, and marine worms in the winter. It is particularly vulnerable to changes in water quality near its breeding sites.

The monarch butterfly is considered a species of special concern under the fSARA and by the COSEWIC (Table 26). The caterpillars are striped yellow, black, and white, the chrysalis is gold-green, and the butterfly is bright orange with heavy black veins (Figure 56). The eastern population, found throughout Atlantic Canada, is the largest of the populations (*i.e.*, outnumbering the western and central groups). The population is estimated in the tens of millions; however, the population can have drastic ups and downs each year depending on the climate. This species tends to be present wherever milkweed (*Asclepius sp.*) and wildflowers, such as goldenrod (*Solidago sp.*), asters (*Aster sp.*), and purple loosestrife (*Lythrum salicaria*), exist.

Endangered species is the rank given to the piping plover *melodus* subspecies (Figure 56) under the fSARA and by the COSEWIC (Table 26). It is a small shorebird that is known to breed along the shores of New Brunswick. They nest above the normal high water mark on exposed sand or gravel beaches. Their nests are most often associated with small cobble and other small beach debris on ocean beaches, sand spits, and barrier beaches. They arrive on the breeding grounds in late April or early May. In 2001, there were 230 pair and 43 individuals in the Atlantic region.

The yellow-banded bumble bee (Figure 56) is medium-sized (*i.e.*, 12 mm to 18 mm long) with a distinct yellow and black abdominal band pattern found on its queens, males, and workers. It has a short tongue relative to other bumble bee species and will compete with other bees for food, pollen, and nectar. It is also known to nectar-rob by reaching through holes bitten in the base of flowers. This species is a habitat generalist and has the ability to use a variety of nectaring plants and environmental conditions. It generally nests underground in abandoned rodent burrows or decomposing logs. Their decline is suspected to be from a combination of factors including the introduction of pathogens from managed bee colonies, pesticide use, climate change, and habitat loss. The yellow-banded bumble bee is ranked as a species of special concern under the fSARA and by the COSEWIC (Table 26).

3.2.1.2 Snapshots of Bats

Although the ACCDC reports did not yield any bat observations, little brown bats, northern bats, and tri-colored bats (*i.e.*, Figure 57) are known to have been seen in the Saint John area. All three are small-bodied bats typical of the plain-nosed bats.

These insectivores live in three different roosting sites: day roosts; night roosts; and hibernation roosts. Hibernation roosting populations have been decimated in recent years. It is estimated that about 6.5 million bats of several species, but primarily the little brown bat, have died in eastern Canada and the northeastern US as a result of white-nose syndrome. Populations in some hibernacula have fallen by more than 75 %. Species modelling has shown that this species could be extirpated by 2030 if declines

continue. Their precipitous declines have resulted in their ranking under the fSARA as endangered. Unaffected, these bats often live well beyond 10 years of age.



Figure 57. Photographs of three bat species listed under the fSARA and by the COSEWIC as being endangered and are known to have been observed within a 5 km radius of the Reversing Falls Mill in Saint John, New Brunswick.

These bats generally range from 6 cm to 10 cm long, weigh less than 10 g, and have an average wingspan under 30 cm. The little brown bats distinguishing feature is a short and blunt tragus (*i.e.*, the inner side of the external ear). The northern bat has a long, slender, and pointed tragus and ears that extend beyond the nose when pressed forward. The tri-colored bat is distinguished by their distinctive tri-colored hairs.

3.2.2 Provincial Species At Risk

Provincially listed species at risk that exist in New Brunswick and could potentially be impacted by the Project are noted in Table 27. Those terrestrial and aquatic species identified under the provincial *Species At Risk Act* (pSARA) [R.S.N.B. 2012, c 6] as being at risk in New Brunswick are listed. Listing of a species in Table 27 does not indicate that it is either present or absent at the Project site. Presence and absence information is provided below. The order of risk level under the pSARA is as follows: special concern; threatened; endangered; and extirpated.

Table 27. Terrestrial and aquatic flora and fauna listed as being at risk in New Brunswick under the pSARA.

Common Name	Scientific Name	pSARA Status
<u>Vascular Plants, Mosses, and Lichens</u>		
Blue felt lichen	<i>Degelia plumbea</i>	Species of special concern
Parker's pipewort	<i>Eriocaulon parkeri</i>	Endangered
Vole ears lichen	<i>Erioderma mollissimum</i>	Endangered
Boreal felt lichen Atlantic population	<i>Erioderma pedicellata</i>	Endangered
Prototype quillwort	<i>Isoetes prototypus</i>	Endangered
Butternut	<i>Juglans cinerea</i>	Endangered
Beach pinweed	<i>Lechea maritima</i>	Species of special concern

Common Name	Scientific Name	pSARA Status
Southern twayblade	<i>Listera australis</i>	Endangered
Furbish's lousewort	<i>Pedicularis furbishiae</i>	Endangered
Van Brunt's Jacob's-ladder	<i>Polemonium vanbruntiae</i>	Threatened
Pinedrops	<i>Pterospora andromedea</i>	Endangered
Anticosti aster	<i>Symphyotrichum anticostense</i>	Endangered
Gulf of St. Lawrence aster	<i>Symphyotrichum laurentianum</i>	Endangered
Bathurst aster Bathurst population	<i>Symphyotrichum subulatum</i>	Endangered
Molluscs		
Dwarf wedgemussel	<i>Alasmidonta heterodon</i>	Extirpated
Brook floater	<i>Alasmidonta varicosa</i>	Species of special concern
Yellow lampmussel	<i>Lampsilis cariosa</i>	Species of special concern
Reptiles		
Loggerhead sea turtle	<i>Caretta caretta</i>	Endangered
Snapping turtle	<i>Chelydra serpentina</i>	Species of special concern
Leatherback sea turtle Atlantic population	<i>Dermochelys coriacea</i>	Endangered
Wood turtle	<i>Glyptemys insculpta</i>	Threatened
Birds		
Short-eared owl	<i>Asio flammeus</i>	Species of special concern
Barrow's goldeneye Eastern population	<i>Bucephala islandica</i>	Species of special concern
Red knot <i>rufa</i> subspecies	<i>Calidris canutus rufa</i>	Endangered
Whip-poor-will	<i>Caprimulgus vociferus</i>	Threatened
Bicknell's thrush	<i>Catharus bicknelli</i>	Threatened
Canada warbler	<i>Cardellina canadensis</i>	Threatened
Chimney swift	<i>Chaetura pelagica</i>	Threatened
Piping Plover <i>melodus</i> subspecies	<i>Charadrius melodus melodus</i>	Endangered
Common nighthawk	<i>Chordeiles minor</i>	Threatened
Olive-sided flycatcher	<i>Contopus cooperi</i>	Threatened
Eastern wood-pewee	<i>Contopus virens</i>	Species of special concern
Yellow rail	<i>Coturnicops noveboracensis</i>	Species of special concern
Bobolink	<i>Dolichonyx oryzivorus</i>	Threatened
Rusty blackbird	<i>Euphagus carolinus</i>	Species of special concern
Peregrine falcon <i>anatum</i> / <i>tundrius</i>	<i>Falco peregrinus anatum/tundrius</i>	Endangered
Bald eagle	<i>Haliaeetus leucocephalus</i>	Endangered
Barn swallow	<i>Hirundo rustica</i>	Threatened
Harlequin duck Eastern population	<i>Histrionicus histrionicus</i>	Endangered
Wood thrush	<i>Hylocichla mustelina</i>	Threatened
Least bittern	<i>Ixobrychus exilis</i>	Threatened
Eskimo curlew	<i>Numenius borealis</i>	Endangered
Horned grebe Western population	<i>Podiceps auritus</i>	Species of special concern
Roseate tern	<i>Sterna dougallii</i>	Endangered
Eastern meadowlark	<i>Sturnella magna</i>	Threatened

Common Name	Scientific Name	pSARA Status
Arthropods		
Cobblestone tiger beetle	<i>Cicindela marginipennis</i>	Endangered
Maritime ringlet	<i>Coenonympha nipisiquit</i>	Endangered
Monarch	<i>Danaus plexippus</i>	Species of special concern
Skillet clubtail	<i>Gomphus ventricosus</i>	Endangered
Pygmy snaketail	<i>Omphiogomphus howei</i>	Species of special concern
Fishes		
Shortnose sturgeon	<i>Acipenser brevirostrum</i>	Species of special concern
Atlantic sturgeon Maritimes populations	<i>Acipenser oxyrinchus</i>	Threatened
Thorny skate	<i>Amblyraja radiata</i>	Species of special concern
Atlantic wolffish	<i>Anarhichas lupus</i>	Species of special concern
American eel	<i>Anguilla rostrata</i>	Threatened
Cusk	<i>Brosme brosme</i>	Endangered
White shark Atlantic population	<i>Carcharodon carcharias</i>	Endangered
Atlantic cod Laurentian south population	<i>Gadus morhua</i>	Endangered
Atlantic cod southern population	<i>Gadus morhua</i>	Endangered
American plaice Maritime population	<i>Hippoglossoides platessoides</i>	Threatened
Mako shortfin Atlantic population	<i>Isurus oxyrinchus</i>	Threatened
Porbeagle	<i>Lamna nasus</i>	Endangered
Winter skate southern Gulf of St. Lawrence population	<i>Leucoraja ocellata</i>	Endangered
Winter skate Georges Bank-Western Scotian Shelf-pop.	<i>Leucoraja ocellata</i>	Species of special concern
Smooth skate Laurentian-Scotian population	<i>Malacoraja senta</i>	Species of special concern
Striped bass Bay of Fundy population	<i>Morone saxatilis</i>	Endangered
Striped bass southern Gulf of St. Lawrence population	<i>Morone saxatilis</i>	Species of special concern
Rainbow smelt Lake Utopia large-bodied population	<i>Osmerus mordax</i>	Threatened
Rainbow smelt Lake Utopia small-bodied population	<i>Osmerus mordax</i>	Threatened
Blue shark Atlantic population	<i>Prionace glauca</i>	Species of special concern
Atlantic salmon Inner Bay of Fundy population	<i>Salmo salar</i>	Endangered
Atlantic salmon Outer Bay of Fundy population	<i>Salmo salar</i>	Endangered
Atlantic salmon Gaspé-S. Gulf of St. Lawrence pop.	<i>Salmo salar</i>	Species of special concern
Acadian redfish Atlantic population	<i>Sebastes fasciatus</i>	Threatened
Spiny dogfish Atlantic population	<i>Squalus acanthias</i>	Species of special concern
Atlantic bluefin tuna	<i>Thunnus thynnus</i>	Endangered
Mammals		
Blue whale - Atlantic population	<i>Balaenoptera musculus</i>	Endangered
Fin whale Atlantic population	<i>Balaenoptera physalus</i>	Species of special concern
Gray wolf	<i>Canis lupus</i>	Extirpated
North Atlantic right whale	<i>Eubalaena glacialis</i>	Endangered
Wolverine	<i>Gulo gulo</i>	Extirpated
Canada lynx	<i>Lynx canadensis</i>	Endangered
Little brown <i>Myotis</i>	<i>Myotis lucifugus</i>	Endangered
Northern <i>Myotis</i>	<i>Myotis septentrionalis</i>	Endangered

Common Name	Scientific Name	pSARA Status
Atlantic walrus	<i>Odobenus rosmarus rosmarus</i>	Extirpated
Tri-colored bat	<i>Perimyotis subflavus</i>	Endangered
Harbour porpoise Northwest Atlantic population	<i>Phocoena phocoena</i>	Species of special concern
Woodland caribou	<i>Rangifer tarandus caribou</i>	Extirpated

The ACCDC databases were queried for known observation data of provincially protected species within a 5 km radius of the Project site (*i.e.*, refer to Appendix VIII). According to the ACCDC data, 12 species listed under the pSARA have been observed (Figure 61).

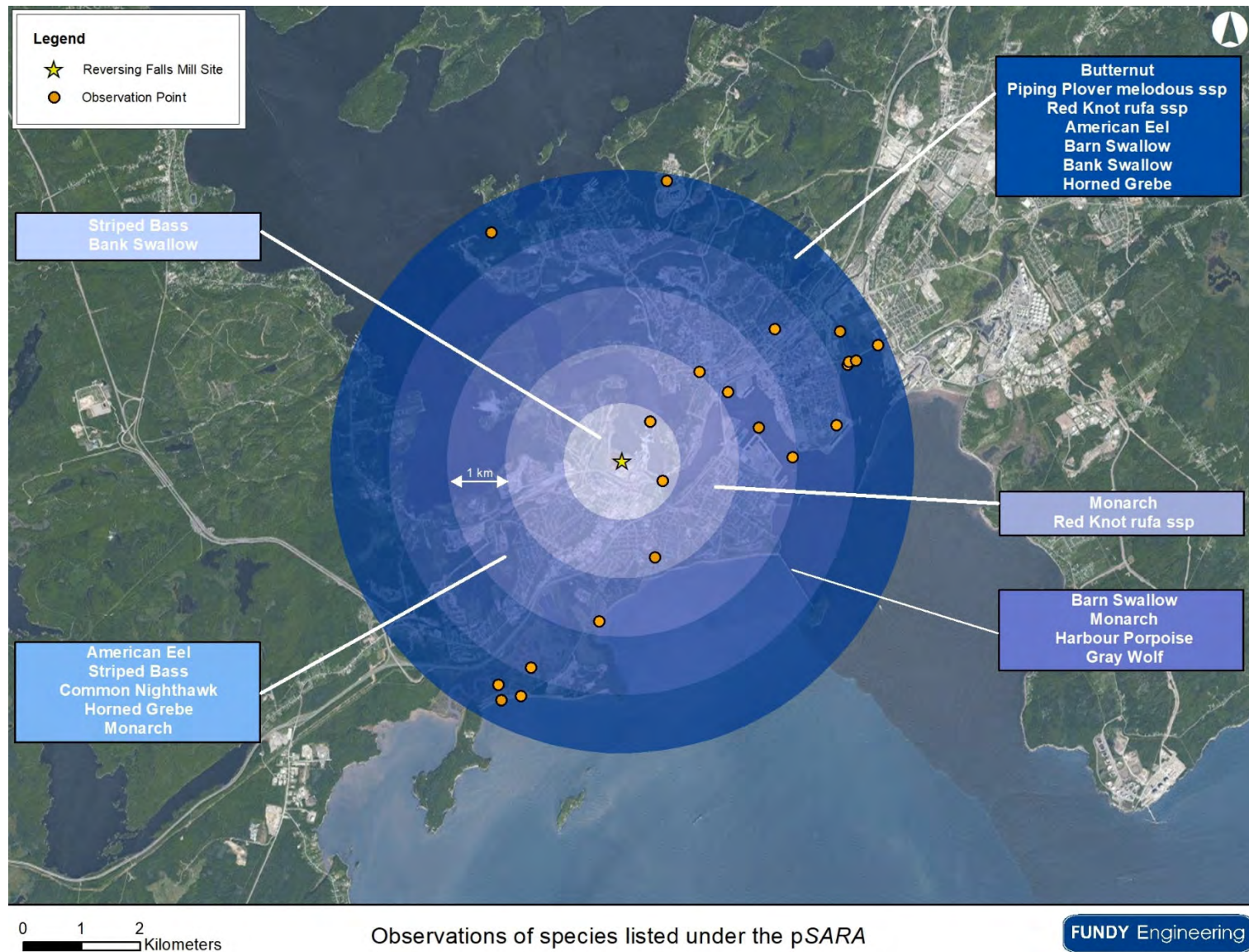

Figure 58. Map showing the recorded observations of species listed under the pSARA within a 5 km radius of the Reversing Falls Mill in Saint John, New Brunswick. Data obtained from the ACCDC.

3.2.2.1 Snapshots of Provincial Species at Risk Locally Present

Those 12 species listed under the pSARA that have been observed within 5 km of the Reversing Falls Mill in Saint John, New Brunswick are shown in Figure 59. Descriptions of those species are also provided if not previously described in Section 3.2.1.1. Detailed information provided below on the protected species was obtained from the species profiles on the fSARA [SARA, 2021], COSWEIC [COSEWIC, 2021], and regulatory agency websites.

The American eel (Figure 59) is a long freshwater fish with a serpentine body, deeply embedded scales, and a single dorsal, caudal, and anal fin that extends around the tail to the ventral side. They grow to a length of between 0.4 m and 1 m long. Its native Canadian range includes all freshwater, estuaries, and coastal marine waters that are accessible to the Atlantic Ocean. Spawning, which occurs only once for an individual between 8 years and 23 years of age, happens only in the Sargasso Sea. The larvae are passively, but widely dispersed by surface currents of the Gulf Stream. Populations of this eel species are affected by climate change, dams and other barriers, biological and chemical contaminants, and commercial fishing. Because of this, they are listed under the pSARA as threatened (Table 27).

The gray wolf (Figure 59) is native to the wilderness and remote areas of North America. Mortality caused by human activity, such as hunting and trapping, road-kills, industrial, agricultural, and residential developments, and the abundance of prey have all affected the gray wolf's numbers and geographic range. In New Brunswick, the gray wolf is listed under the pSARA as being extirpated (Table 27). Gray wolves are territorial and wolf packs fiercely defend their turf. They feed on a wide-variety of animals and birds. Because they have been eliminated in many areas of their original geographic range, many of those populations that remain are heavily protected. They are an often feared and maligned species that has a characteristic howl.

The harbour porpoise (Figure 59) is one of the smallest and shortest-lived whales; they generally do not exceed 1.7 m long, a weight of 65 kg, or in excess of 20 years. These mottled greyish-white porpoises are widely distributed over the continental shelves of the temperate northern hemisphere. Estimates peg the population of harbour porpoises in eastern Canada to be about 50 000. These relatively shy and solitary animals do not respond well to intensive human activities in coastal waters. The primary threat to the harbour porpoise in eastern Canada is bycatch in bottom-set gill nets used by groundfishers. Other threats include habitat degradation, loss of habitat, and environmental contamination. The harbour porpoise is listed as a species of special concern under the pSARA (Table 27).

The red knot *rufa* subspecies is a medium-sized shorebird (*i.e.*, 25 cm long) with a long straight bill, small head, long legs, and long tapered wings. They have an extreme migration route from the central Canadian Arctic to the southern tip of South America. One of the most important areas for these migrants is the north shore of the St. Lawrence. The primary reason for their precipitous decline is the overfishing of horseshoe crabs in Delaware Bay, which they feed upon prior to their final push into the Canadian Arctic. Migratory stopovers include vast coastal zone sand flats and mudflats. Under the pSARA, the red knot (Figure 59) is ranked as an endangered species (Table 27).

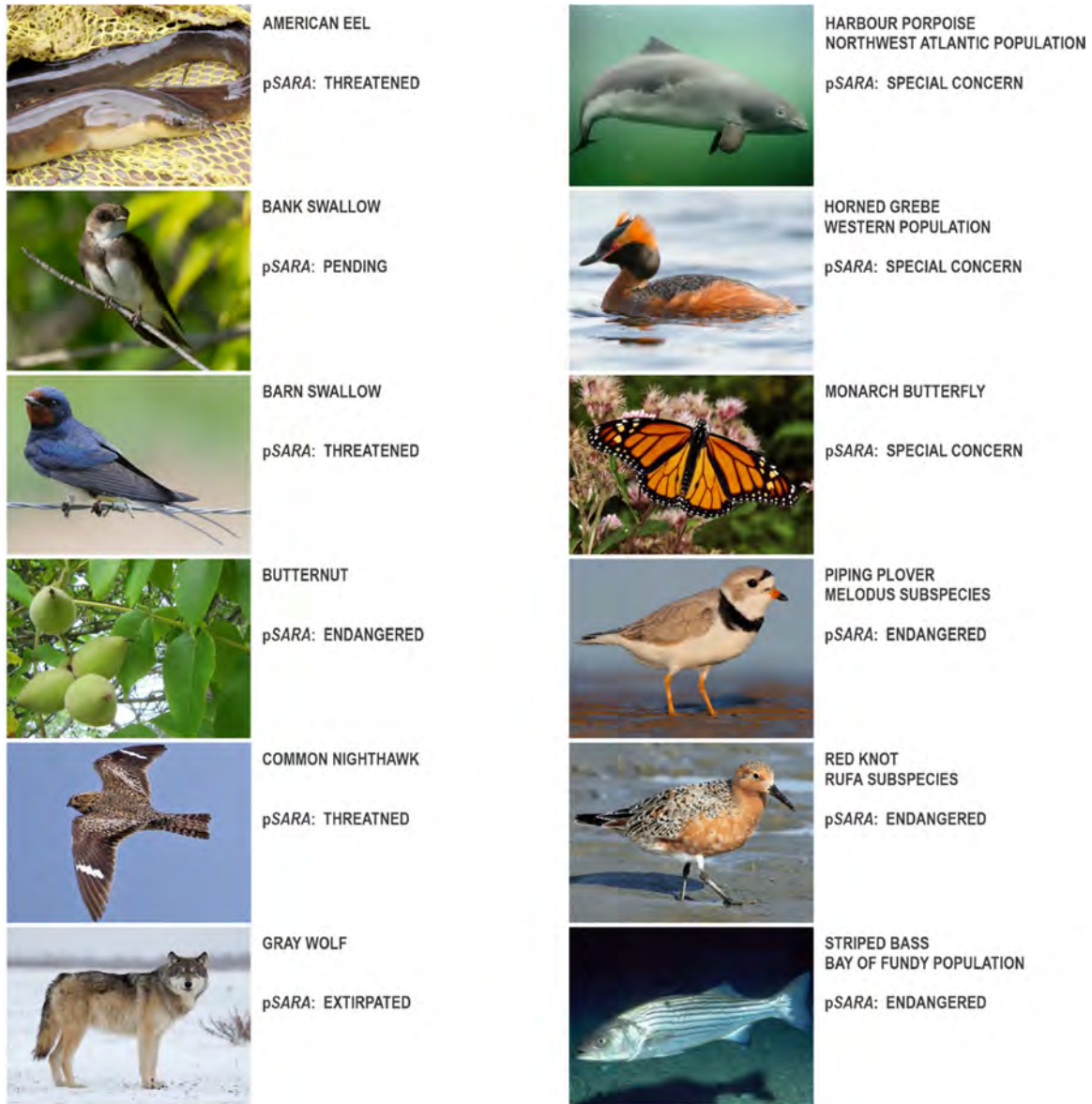

Figure 59. Photographs of species listed under the pSARA that have been observed within a 5 km radius of the Reversing Falls Mill in Saint John, New Brunswick.

The Bay of Fundy population of the striped bass (Figure 59) is listed as endangered under the pSARA (Table 27). It is a large-bodied (*i.e.*, they can grow up to 1.8 m long) and long-lived (*i.e.*, up to 30 years) anadromous fish prized by anglers. Historically, the species spawned in the Annapolis River and the Shubenacadie River in Nova Scotia and the Saint John River in New Brunswick. The installation of hydroelectric dams on the Annapolis River and the Saint John River mean that the only river left for them to spawn is the Shubenacadie whose headwaters habitat continues to degrade. It is susceptible to exploitation from recreational fishing, by-catch in commercial fisheries, and from poaching.

3.2.3 Location-Sensitive Species

The New Brunswick Department of Natural Resources and Energy Development (NBDNRED) considers several species in the Province as “location-sensitive”. The ACCDC databases show three location-sensitive species for the area: wood turtle; bald eagle; and peregrine falcon (Figure 60). Bat hibernacula also appear on the location-sensitive query (*i.e.*, refer to Appendix VIII). The three bat species that would use those hibernacula are described in Section 3.2.1.2.



Figure 60. Photographs of location-sensitive species included in the ACCDC data report within a 5 km radius of *The Crossing* proposed for east Saint John, New Brunswick.

The bald eagle (Figure 60) is a large bird of prey with a distribution across North America and generally found near large bodies of open water that are near an abundant food supply and old-growth trees for nesting. Between the 1940s and 1970s, their numbers considerably declined due to intense hunting, unintentional poisonings (*e.g.*, DDT and lead shot), and habitat destruction. Juveniles are dark brown with white streaking throughout, while adults support the white head and tail. At maturity, the bald eagle has a wingspan between 1.8 m and 2.3 m and can weigh up to 6 kg. Although the number of bald eagles has drastically increased over the past few decades to the point where they are no longer a species listed under the fSARA or by the COSEWIC, they are still listed as being endangered under the pSARA.

The *anatum* subspecies of the peregrine falcon (Figure 60) is a high-speed bird of prey slightly smaller and more streamlined than a hawk. Great declines in peregrine populations were observed following the introduction of the pesticide Dichloro-Diphenyl-Trichloroethane (DDT); however, their populations began to increase following DDT restrictions that were established in 1970. It is estimated that there are 500 pair in Canada. Because of this low number, they are listed as a threatened species under the pSARA, fSARA, and by the COSEWIC. Peregrine nests are usually scrapes made on cliff ledges near wetlands. Their nesting territory is about a 1 km radius around the nest and their home range extends to a radius of up to 27 km. They prefer open habitats such as wetlands, but they are known to hunt over open forest.

The wood turtle (Figure 60) inhabits a broad range of habitats. They prefer to be near areas of moderately flowing water (*e.g.*, streams, creeks, and rivers), and they favour riparian areas with open canopy. During the summer, the wood turtle prefers to be on the

ground in forested areas. In spring and fall they prefer to be near water and they overwinter in the water. Wood turtles appear to select habitats, rather than randomly using areas. The damming of watercourses, loss and degradation of riparian habitat, road mortality, and the pet trade all threaten the wood turtle population. They are considered sensitive to pollution as evidenced by their disappearance from low-quality watercourses. Pesticides and insecticides also threaten the population. No New Brunswick population is known to exceed 100 individuals. Although evidence suggests that populations are common and stable, the wood turtle is ranked as a threatened species under the pSARA, fSARA, and by the COSEWIC.

3.2.4 Other Locally Observed Species

ACCDC databases were also queried for known observation data of provincially ranked flora and fauna within a 5 km radius of the Project site. Those species identified in the sections above are not included here. Because there are many wildlife enthusiasts in the region, the listing of flora and fauna is fairly extensive. The full list of the flora and fauna within 5 km of the site is provided in Table 27 and the ACCDC report can be found in Appendix VIII. Interpretation of the ACCDC S-rank system is provided in Table 29.

A visual representation of the 121 observed flora species is provided in Figure 61. Similarly, a visual representation of the 81 observed fauna species is provided in Figure 62 and Figure 63.

Table 28. List of provincially ranked flora and fauna identified by the ACCDC as being observed within 5 km of the Reversing Falls Mill in Saint John, New Brunswick.

Common Name	Scientific Name	S-rank	NB GS Rank
Flora			
Northern maidenhair fern	<i>Adiantum pedatum</i>	S3	Secure
Canada serviceberry	<i>Amelanchier canadensis</i>	S3	Secure
Moss	<i>Anomodon viticulosus</i>	S2	Secure
Pussy-toes	<i>Antennaria howellii ssp. petaloidea</i>	S1	Secure
Cream-flowered rockcress	<i>Arabis pycnocarpa</i>	S3	Secure
Tall wormwood	<i>Artemisia campestris ssp. caudata</i>	S3	Secure
Maidenhair spleenwort	<i>Asplenium trichomanes</i>	S2	Secure
Green spleenwort	<i>Asplenium viride</i>	S3	Secure
Alpine milk-vetch	<i>Astragalus alpinus</i>	S3	Secure
Bog birch	<i>Betula pumila</i>	S3	Secure
Estuary beggarticks	<i>Bidens hyperborea</i>	S3	Common
Strawberry-blite	<i>Blitum capitatum</i>	S1	Secure
Red bulrush	<i>Blysmopsis rufa</i>	S2	Secure
Drummond's rockcress	<i>Boechera stricta</i>	S2	Secure
Narrow triangle moonwort	<i>Botrychium lanceolatum ssp. angustisegmentum</i>	S3	Secure
Slim-stemmed reed grass	<i>Calamagrostis stricta</i>	S3S4	Secure
Common large wetland moss	<i>Calliergonella cuspidata</i>	S2S3	Secure
Large toothwort	<i>Cardamine maxima</i>	S3	Secure
Lesser brown sedge	<i>Carex adusta</i>	S2S3	Secure

Common Name	Scientific Name	S-rank	NB GS Rank
Northern clustered sedge	<i>Carex arcta</i>	S3	Secure
Scabrous black sedge	<i>Carex atratifomis</i>	S3	Secure
Hairlike sedge	<i>Carex capillaris</i>	S3	Secure
Livid sedge	<i>Carex livida</i>	S2	Secure
Michaux's sedge	<i>Carex michauxiana</i>	S3	Secure
Rosy sedge	<i>Carex rosea</i>	S3	Secure
Saltmarsh sedge	<i>Carex salina</i>	S2	Secure
Russet sedge	<i>Carex saxatilis</i>	S1	Secure
Tender sedge	<i>Carex tenera</i>	S3	Secure
Tuckerman's sedge	<i>Carex tuckermanii</i>	S3	Secure
Purple clematis	<i>Clematis occidentalis</i>	S3	Secure
Bastard's toadflax	<i>Comandra umbellata</i>	S3	Secure
Spotted coralroot	<i>Corallorhiza maculata</i>	S3S4	Secure
Broom crowberry	<i>Corema conradii</i>	S1	Common
Sieve-toothed moss	<i>Coscinodon cribrosus</i>	S1	Uncommon to Common
Quebec hawthorn	<i>Crataegus submollis</i>	S3?	Secure
Steller's rockbrake	<i>Cryptogramma stelleri</i>	S3	Secure
Buttonbush dodder	<i>Cuscuta cephalanthi</i>	S1S3	Secure
Toothed flatsedge	<i>Cyperus dentatus</i>	S3	Common
Perennial yellow nutsedge	<i>Cyperus esculentus var. leptostachyus</i>	S3	Secure
Rigid screw moss	<i>Didymodon rigidulus</i>	S2S3	Secure
Savin-leaved ground-cedar	<i>Diphasiastrum x sabinifolium</i>	S3	Common
Tall wood beauty	<i>Dryocallis arguta</i>	S3S4	Secure
Fragrant wood fern	<i>Dryopteris fragrans</i>	S3	Secure
Canada wild rye	<i>Elymus canadensis</i>	S2	Secure
Purple-veined willowherb	<i>Epilobium coloratum</i>	S2S3	Secure
Downy willowherb	<i>Epilobium strictum</i>	S3	Secure
Tufted love grass	<i>Eragrostis pectinacea</i>	S2S3	Secure
Hyssop-leaved fleabane	<i>Erigeron hyssopifolius</i>	S3	Secure
Climbing false buckwheat	<i>Fallopia scandens</i>	S3	Secure
Bush's pocket moss	<i>Fissidens bushii</i>	S2S3	Secure
Black ash	<i>Fraxinus nigra</i>	S4S5	Secure
Northern bedstraw	<i>Galium boreale</i>	S3	Secure
Limestone swamp bedstraw	<i>Galium brevipes</i>	S1	Common
Blunt-leaved bedstraw	<i>Galium obtusum</i>	S2?	Secure
Northern gentian	<i>Gentianella amarella ssp. acuta</i>	S3	Secure
Northern comandra	<i>Geocaulon lividum</i>	S3S4	Secure
Bicknell's crane's-bill	<i>Geranium bicknellii</i>	S3	Secure
Herb Robert	<i>Geranium robertianum</i>	S2S3	Secure
Toothless grimmia moss	<i>Grimmia anodon</i>	SH	Secure
American false pennyroyal	<i>Hedeoma pulegioides</i>	S2	Secure
Alpine hedsarum	<i>Hedysarum americanum</i>	S3	Secure
Water stargrass	<i>Heteranthera dubia</i>	S3	Secure
Woolly beach-heath	<i>Hudsonia tomentosa</i>	S3	Secure

Common Name	Scientific Name	S-rank	NB GS Rank
Mountain firmoss	<i>Huperzia appressa</i>	S3	Secure
Tuckerman's quillwort	<i>Isoetes tuckermanii</i>	S3	Common to Secure
Creeping juniper	<i>Juniperus horizontalis</i>	S3S4	Secure
Loesel's twayblade	<i>Liparis loeselii</i>	S3	Secure
Cardinal flower	<i>Lobelia cardinalis</i>	S3	Secure
Brook lobelia	<i>Lobelia kalmii</i>	S3S4	Secure
Sea lungwort	<i>Mertensia maritima</i>	S3S4	Secure
Whorled water milfoil	<i>Myriophyllum verticillatum</i>	S3	Secure
Glaucous rattlesnakeroot	<i>Nabalus racemosus</i>	S3	Secure
Moss	<i>Neckera complanata</i>	S2S3	Secure
Auricled twayblade	<i>Neottia auriculata</i>	S2S3	Uncommon to Common
Small yellow pond-lily	<i>Nuphar microphylla</i>	S3	Secure
Northern adder's-tongue	<i>Ophioglossum pusillum</i>	S2S3	Secure
Red goosefoot	<i>Oxybasis rubra</i>	S2	Secure
Fen grass-of-parnassus	<i>Parnassia glauca</i>	S3	Secure
White fringed orchid	<i>Platanthera blephariglottis</i>	S3	Secure
Glaucous blue grass	<i>Poa glauca</i>	S2	Secure
Appalachian polypody	<i>Polypodium appalachianum</i>	S3	Common to Secure
Blunt-leaved pondweed	<i>Potamogeton obtusifolius</i>	S3	Secure
White-stemmed pondweed	<i>Potamogeton praelongus</i>	S2S3	Secure
Richardson's pondweed	<i>Potamogeton richardsonii</i>	S3	Secure
Mistassini primrose	<i>Primula mistassinica</i>	S3	Secure
Macoun's cudweed	<i>Pseudognaphalium macounii</i>	S2	Secure
Tall clustered bryum	<i>Ptychostomum pallescens</i>	S2?	Secure
Bur oak	<i>Quercus macrocarpa</i>	S2	Secure
Cursed buttercup	<i>Ranunculus sceleratus</i>	S1	Secure
Roseroot	<i>Rhodiola rosea</i>	S3	Secure
Swamp rose	<i>Rosa palustris</i>	S3	Secure
Cloudberry	<i>Rubus chamaemorus</i>	S3S4	Secure
Northern dewberry	<i>Rubus flagellaris</i>	S1	Secure
Knotted pearlwort	<i>Sagina nodosa</i>	S2	Secure
Sandbar willow	<i>Salix interior</i>	S3	Secure
Black willow	<i>Salix nigra</i>	S3	Secure
Bog willow	<i>Salix pedicellaris</i>	S3	Secure
Dissected moonwort	<i>Sceptridium dissectum</i>	S3	Secure
Torrey's bulrush	<i>Schoenoplectus torreyi</i>	S3	Secure
Hooked scorpion moss	<i>Scorpidium scorpioides</i>	S2S3	Secure
Low spikemoss	<i>Selaginella selaginoides</i>	S2	Secure
Narrow-leaved blue-eyed-grass	<i>Sisyrinchium angustifolium</i>	S1	Secure
Blue-stemmed goldenrod	<i>Solidago caesia</i>	SX	Secure
Hairy hedge-nettle	<i>Stachys pilosa</i>	S3S4	Secure
Saltmarsh starwort	<i>Stellaria humifusa</i>	S3	Secure
Long-leaved starwort	<i>Stellaria longifolia</i>	S2	Secure
Thread-leaved pondweed	<i>Stuckenia filiformis</i>	S2S3	Secure

Common Name	Scientific Name	S-rank	NB GS Rank
Anticosti aster	<i>Symphyotrichum anticostense</i>	S2S3	Uncommon
New York aster	<i>Symphyotrichum novi-belgii</i> var. <i>crenifolium</i>	S2?	Secure
Northern meadow-rue	<i>Thalictrum confine</i>	S3	Secure
Mucronate screw moss	<i>Tortula mucronifolia</i>	S2	Secure
Sticky false-asphodel	<i>Triantha glutinosa</i>	S3	Secure
Acid-soil moss	<i>Trichostomum tenuirostre</i>	S3S4	Secure
Gaspé arrowgrass	<i>Triglochin gaspensis</i>	S3S4	Common to Secure
Tower mustard	<i>Turritis glabra</i>	S3	Secure
Hooked violet	<i>Viola adunca</i>	S3	Secure
Northern bog violet	<i>Viola nephrophylla</i>	S3	Secure
Northern yellow-eyed-grass	<i>Xyris montana</i>	S3	Secure
Horned pondweed	<i>Zannichellia palustris</i>	S3	Secure
Southern wild rice	<i>Zizania aquatica</i>	S2	Secure

Fauna

Spotted sandpiper	<i>Actitis macularius</i>	S3S4B,S5M	Secure
Mottled darner	<i>Aeshna clepsydra</i>	S2	Common to Secure
Razorbill	<i>Alca torda</i>	S2B,S3N,S3M	Secure
Northern pintail	<i>Anas acuta</i>	S3B,S5M	Secure
Snow goose	<i>Anser caerulescens</i>	S2M	Secure
Ruddy turnstone	<i>Arenaria interpres</i>	S3M	Secure
Long-eared owl	<i>Asio otus</i>	S2S3	Secure
Lesser scaup	<i>Aythya affinis</i>	S1B,S4M	Secure
Redhead	<i>Aythya americana</i>	S1B,S1M	Secure
Greater scaup	<i>Aythya marila</i>	S1B,S4M,S2N	Secure
Gypsy cuckoo bumblebee	<i>Bombus (Psithyrus) bohemicus</i>	S1	Uncommon to Secure
Yellow-banded bumblebee	<i>Bombus terricola</i>	S3?	Uncommon to Common
Brant	<i>Branta bernicla</i>	S1N,S2S3M	Secure
Snowy owl	<i>Bubo scandiacus</i>	S1N,S2S3M	Secure
Bufflehead	<i>Bucephala albeola</i>	S3M,S2N	Secure
Red-shouldered hawk	<i>Buteo lineatus</i>	S2B,S2M	Secure
Lapland longspur	<i>Calcarius lapponicus</i>	S2S3N,SUM	Secure
Sanderling	<i>Calidris alba</i>	S3S4M,S1N	Secure
Baird's sandpiper	<i>Calidris bairdii</i>	S1S2M	Secure
Purple sandpiper	<i>Calidris maritima</i>	S3M,S3N	Secure
Pectoral sandpiper	<i>Calidris melanotos</i>	S3S4M	Secure
Semipalmated sandpiper	<i>Calidris pusilla</i>	S3S4M	Secure
Buff-breasted sandpiper	<i>Calidris subruficollis</i>	SNA	Common
Hoary elfin	<i>Callophrys polios</i>	S3	Secure
Turkey vulture	<i>Cathartes aura</i>	S3B,S3M	Secure
Black guillemot	<i>Cephus grylle</i>	S3	Secure
Killdeer	<i>Charadrius vociferus</i>	S3B,S3M	Secure
Black-headed gull	<i>Chroicocephalus ridibundus</i>	S1N,S2M	Secure
Ladybird beetle	<i>Coccinella hieroglyphica kirbyi</i>	S3	Secure

Common Name	Scientific Name	S-rank	NB GS Rank
Transverse lady beetle	<i>Coccinella transversoguttata richardsoni</i>	SH	Secure
Evening grosbeak	<i>Coccothraustes vespertinus</i>	S3B,S3S4N,SUM	Secure
Black-billed cuckoo	<i>Coccyzus erythrophthalmus</i>	S3B,S3M	Secure
Elderberry borer	<i>Desmocerus palliatus</i>	S3	Secure
Tall wood beauty	<i>Dryocallis arguta</i>	S3S4	Secure
Willow flycatcher	<i>Empidonax traillii</i>	S1S2B,S1S2M	Secure
Horned lark	<i>Eremophila alpestris</i>	S1B,S4N,S5M	Secure
American coot	<i>Fulica americana</i>	S1S2B,S1S2M	Secure
Wilson's snipe	<i>Gallinago delicata</i>	S3S4B,S5M	Secure
Longhorned beetle	<i>Gnathacmaeops pratensis</i>	S3	Secure
Parenthesis lady beetle	<i>Hippodamia parenthesis</i>	S3	Secure
Baltimore oriole	<i>Icterus galbula</i>	S3B,S3M	Secure
Ring-billed gull	<i>Larus delawarensis</i>	S3S4B,S5M	Secure
Glaucous gull	<i>Larus hyperboreus</i>	S2N,S2M	Secure
Longhorned beetle	<i>Lepturopsis biforis</i>	S3	Secure
Laughing gull	<i>Leucophaeus atricilla</i>	S1B,S1M	Secure
Hudsonian godwit	<i>Limosa haemastica</i>	S3S4M	Common
Red crossbill	<i>Loxia curvirostra</i>	S3	Secure
Gadwall	<i>Mareca strepera</i>	S2B,S3M	Secure
Black scoter	<i>Melanitta americana</i>	S3M,S1S2N	Secure
Red-breasted merganser	<i>Mergus serrator</i>	S3B,S5M,S4S5N	Secure
Northern mockingbird	<i>Mimus polyglottos</i>	S2B,S2M	Secure
Brown-headed cowbird	<i>Molothrus ater</i>	S3B,S3M	Secure
Striped bass	<i>Morone saxatilis</i>	S3	Secure
Black-crowned night-heron	<i>Nycticorax nycticorax</i>	S1S2B,S1S2M	Secure
Compton tortoiseshell	<i>Nymphalis l-album</i>	S3	Secure
Ruddy duck	<i>Oxyura jamaicensis</i>	S1B,S2S3M	Secure
Cliff swallow	<i>Petrochelidon pyrrhonota</i>	S2S3B,S2S3M	Secure
Great cormorant	<i>Phalacrocorax carbo</i>	S2N,S2M	Secure
Red-necked phalarope	<i>Phalaropus lobatus</i>	S3M	Common to Secure
Wilson's phalarope	<i>Phalaropus tricolor</i>	S1B,S1M	Secure
American golden-plover	<i>Pluvialis dominica</i>	S2S3M	Secure
Black-bellied plover	<i>Pluvialis squatarola</i>	S3S4M	Secure
Red-necked grebe	<i>Podiceps grisegena</i>	S3M,S2N	Secure
Longhorned beetle	<i>Pogonocherus mixtus</i>	S3	Secure
Prothonotary warbler	<i>Protonotaria citrea</i>	SNA	Secure
Virginia rail	<i>Rallus limicola</i>	S3B,S3M	Secure
Bank swallow	<i>Riparia riparia</i>	S2S3B,S2S3M	Secure
Acadian hairstreak	<i>Satyrium acadica</i>	S3	Secure
Common eider	<i>Somateria mollissima</i>	S3B,S4M,S3N	Secure
Northern shoveler	<i>Spatula clypeata</i>	S2S3B,S2S3M	Secure
Aphrodite fritillary	<i>Speyeria aphrodite</i>	S3	Secure
Pine siskin	<i>Spinus pinus</i>	S3	Secure
Saltmarsh hydrobe	<i>Spurwinkia salsa</i>	S3	Common to Secure

Common Name	Scientific Name	S-rank	NB GS Rank
Common tern	<i>Sterna hirundo</i>	S3B,SUM	Secure
Brown thrasher	<i>Toxostoma rufum</i>	S2B,S2M	Secure
Lesser yellowlegs	<i>Tringa flavipes</i>	S4M	Secure
Greater yellowlegs	<i>Tringa melanoleuca</i>	S1?B,S5M	Secure
Willet	<i>Tringa semipalmata</i>	S3B,S3M	Secure
Solitary sandpiper	<i>Tringa solitaria</i>	S2B,S5M	Secure
House wren	<i>Troglodytes aedon</i>	S1S2B,S1S2M	Secure
Eastern kingbird	<i>Tyrannus tyrannus</i>	S3S4B,S3S4M	Secure
Yellow-throated vireo	<i>Vireo flavifrons</i>	S1?B,S1?M	Secure

Table 29. The Atlantic Canada Conservation Data Centre's Sub-national (*i.e.*, provincial) rarity rank (S-rank) of species and S-rank definitions.

ACCDC S-rank	Definition
S1	Extremely rare: may be especially vulnerable to extirpation; typically five or fewer occurrences or very few remaining individuals.
S2	Rare: may be vulnerable to extirpation due to rarity or other factors; six to 20 occurrences or few remaining individuals.
S3	Uncommon: found only in a restricted range, even if abundant at some locations; 21 to 100 occurrences.
S4	Usually widespread, fairly common: apparently secure with many occurrences, but of longer-term concern (<i>e.g.</i> , watch list); 100 + occurrences).
S5	Abundant: widespread and secure under present conditions.
S#S#	Numeric range rank: a range between two consecutive ranks for a species / community; denotes uncertainty about the exact rarity (<i>e.g.</i> , S1S2).
SH	Historical: previously occurred in the province but may have been overlooked during the past 20 years to 70 years; presence is suspected and will likely be rediscovered.
SU	Unrankable: possibly in peril, but status is uncertain; need more information.
SX	Extinct / Extirpated: believed to be extirpated from its former range.
S?	Unranked: not yet ranked.
SA	Accidental: accidental or casual, infrequent and far outside usual range; includes species (usually birds or butterflies) recorded once or twice or only at very great intervals, hundreds, or even thousands of miles outside their usual range.
SE	Exotic: an exotic established in the province (<i>e.g.</i> , Purple Loosestrife or Coltsfoot); may be native in nearby regions.
SE#	Exotic numeric: an established exotic that has been assigned a rank.
SP	Potential: potentially occurs, but no occurrences have been reported.
SR	Reported: no persuasive documentation (<i>e.g.</i> , misidentified specimen).
SRF	Reported falsely: erroneously reported and the error has persisted in the literature.
SZ	Zero: not of practical conservation concern because there are no definable occurrences, although the species is native and appears regularly; an SZ rank is generally used for occasional long distance migrants.

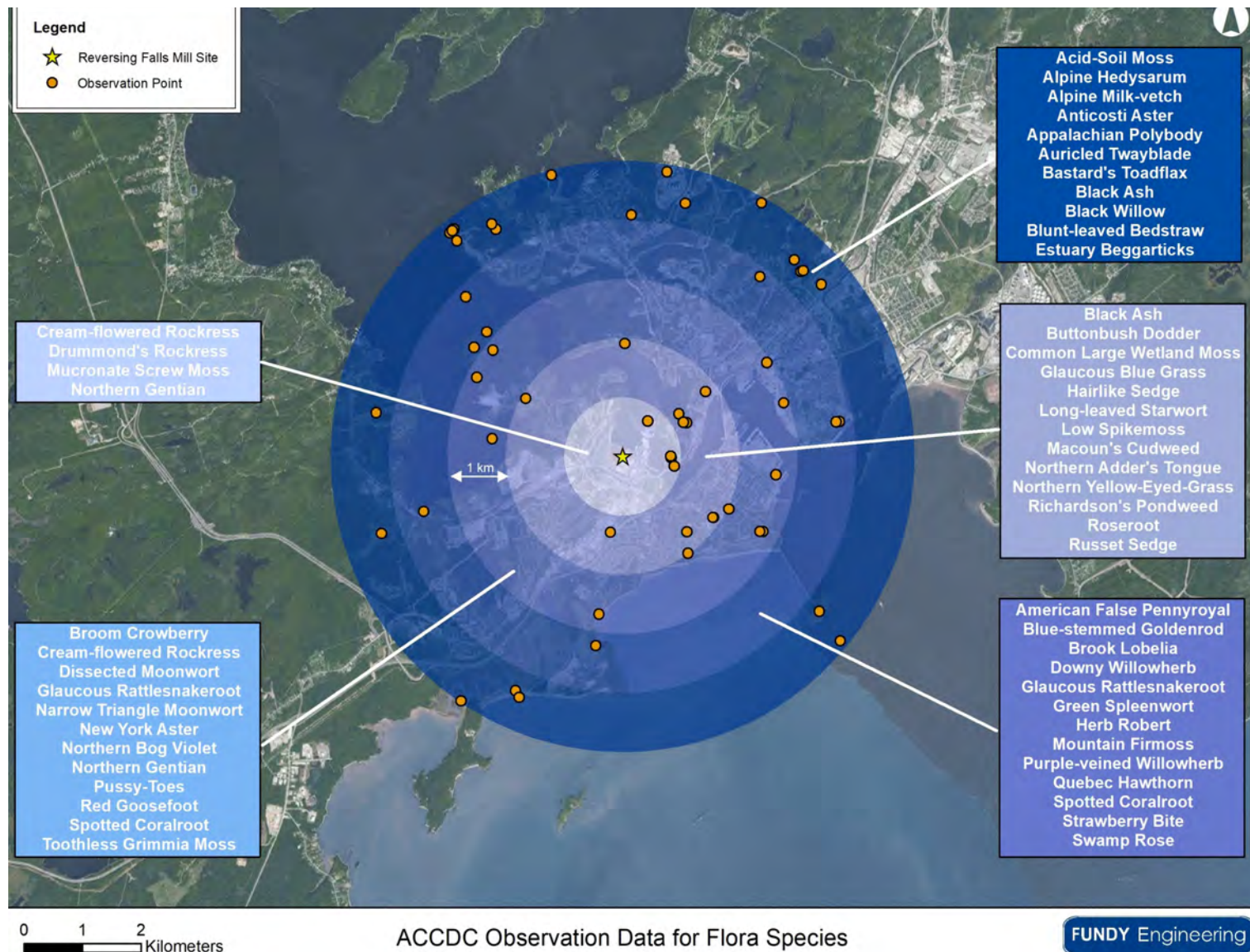

Figure 61. Map showing the observed flora species within a 5 km radius of the Reversing Falls Mill in Saint John, New Brunswick. Data obtained from the ACCDC.

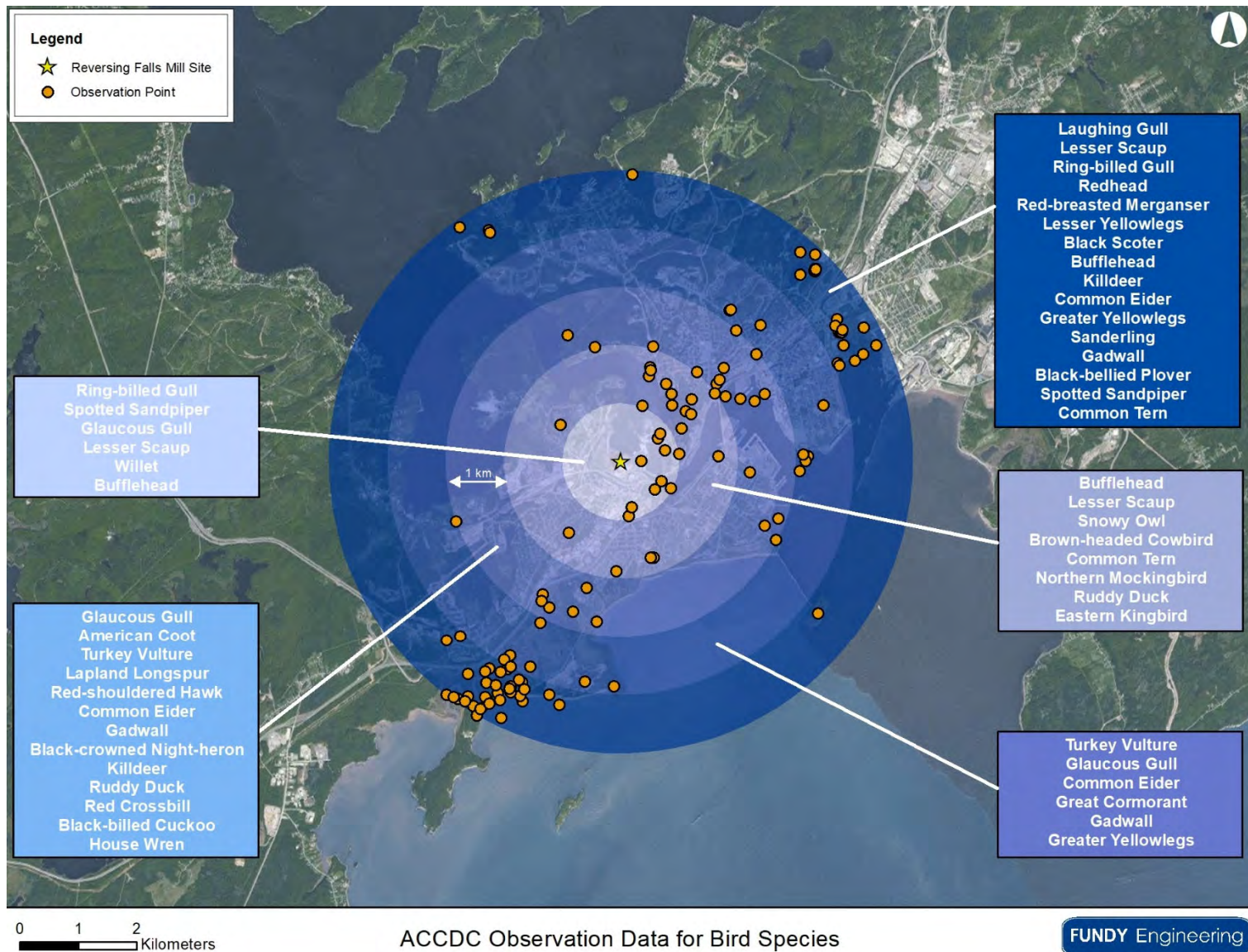

Figure 62. Map showing the observed birds within a 5 km radius of the Reversing Falls Mill in Saint John, New Brunswick. Data obtained from the ACCDC.

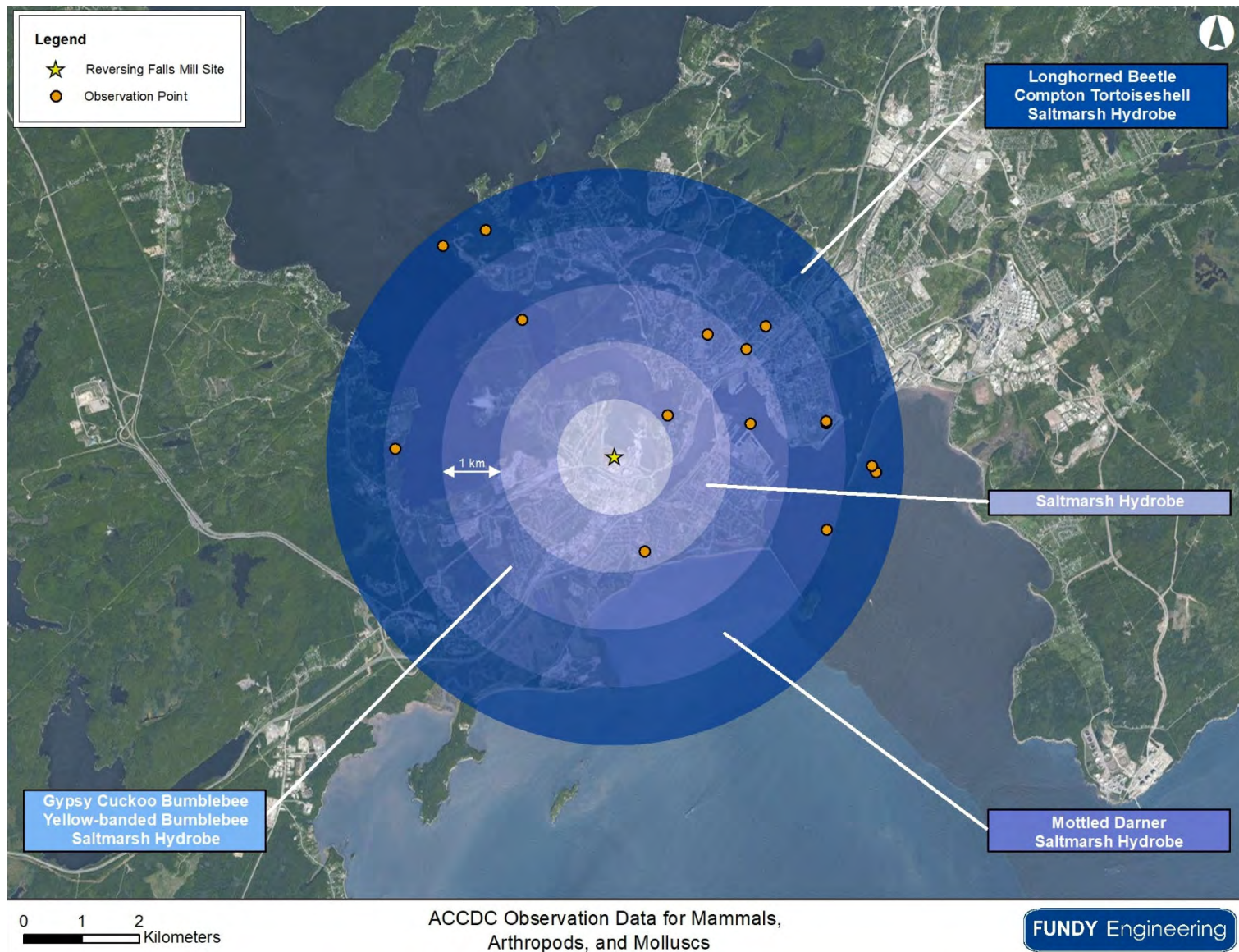

Figure 63. Map showing observed mammals, arthropods, and molluscs within a 5 km radius of the Reversing Falls Mill in Saint John, New Brunswick. Data obtained from the ACCDC.

During the site visits, no terrestrial flora and fauna species of special concern were noted (*n.b.*, the site is fairly devoid of vegetation). None of the areas where proposed equipment will be constructed and operated are virgin lands. It is possible that species listed above either live in adjacent areas or may migrate through the area on occasion.

The Canadian Rivers Institute (CRI), in their 2011 State of the Environment Report on the Saint John River, report that $53 \pm$ fish species occur within the Saint John River system. Species that have been reported within the Lower Saint John River (*i.e.*, from Oak Point to Reversing Falls) are summarized in Table 30.

Table 30. Fish species observed within the Lower Saint John River (*i.e.*, from Oak Point to Reversing Falls) as reported in *Kidd et al.* [2011].

Common Name	Scientific Name	Data Source
Shortnose sturgeon	<i>Acipenser brevirostrum</i>	Historical records and CRI surveys
Atlantic sturgeon	<i>Acipenser oxyrinchus</i>	Historical records and CRI surveys
Blueback herring	<i>Alosa aestivalis</i>	Historical records and CRI surveys
Alewife	<i>Alosa pseudoharengus</i>	Historical records and CRI surveys
American shad	<i>Alosa sapidissima</i>	Historical records
Brown bullhead catfish	<i>Ameiurus nebulosus</i>	Historical records and CRI surveys
American eel	<i>Anguilla rostrata</i>	Historical records and CRI surveys
Fourspine stickleback	<i>Apeltes quadracus</i>	Historical records and CRI surveys
Atlantic menhaden	<i>Brevoortia tyrannus</i>	Historical records
Longnose sucker	<i>Catostomus catostomus</i>	Historical records and CRI surveys
White sucker	<i>Catostomus commersonii</i>	Historical records and CRI surveys
Lake whitefish	<i>Coregonus clupeaformis</i>	Historical records
Slimy sculpin	<i>Cottus cognatus</i>	Historical records and known from tributaries
Chain pickerel	<i>Esix niger</i>	Historical records and CRI surveys
Banded killifish	<i>Fundulus diaphanous</i>	Historical records and CRI surveys
Threespine stickleback	<i>Gasterosteus aculeatus</i>	Historical records and CRI surveys
Redbreast sunfish	<i>Lepomis auritus</i>	Historical records and CRI surveys
Pumpkinseed sunfish	<i>Lepomis gibbosus</i>	Historical records and CRI surveys
Yellowtail flounder	<i>Limanda ferruginea</i>	Historical records
Burbot	<i>Lota lota</i>	Historical records and known from tributaries
Common shiner	<i>Luxilus cornutus</i>	Historical records and CRI surveys
Atlantic silverside	<i>Menidia menidia</i>	Historical records
Atlantic tomcod	<i>Microgadus tomcod</i>	Historical records and CRI or DNR studies
Smallmouth bass	<i>Micropterus dolomieu</i>	Historical records and CRI surveys
White perch	<i>Morone americana</i>	Historical records and CRI surveys
Striped bass	<i>Morone saxatilis</i>	Historical records and CRI or DNR studies
Golden shiner	<i>Notemigonus crysoleucas</i>	Historical records and CRI surveys
Rainbow trout	<i>Oncorhynchus mykiss</i>	Known from tributaries
Rainbow smelt	<i>Osmerus mordax</i>	Historical records and CRI surveys
Yellow perch	<i>Perca flavescens</i>	Historical records and CRI surveys
Sea lamprey	<i>Petromyzon marinus</i>	Known from tributaries
Ninespine stickleback	<i>Pungitius pungitius</i>	CRI surveys
Blacknose dace	<i>Rhinichthys atratulus</i>	Historical records and known from tributaries
Atlantic salmon	<i>Salmo salar</i>	Historical records and known from tributaries
Brook trout	<i>Salvelinus fontinalis</i>	Historical records and known from tributaries
Creek chub	<i>Semotilus atromaculatus</i>	Historical records and known from tributaries
White hake	<i>Urophycis tenuis</i>	Historical records

No independent assessment was undertaken by the Proponent with respect to the existing fish habitat characteristics or the fish species that may be present in the area. Instead, information collected from others is presented here.

Several CRI researchers and representatives with the Saint John Chapter of the Atlantic Coastal Action Program (ACAPSJ) were contacted regarding fishes and invertebrates that may use the area in and around Reversing Falls. Although none of those individuals contacted have specifically conducted research within Reversing Falls, they have done work in nearby areas. A species summary for those various locations, shown in Figure 64, is provided in Table 31.

There is known to be a recreational sport fishery for striped bass within Reversing Falls.



Figure 64. Areas of the Lower Saint John River that have been investigated by various researchers and where species observations are available.

Table 31. Species that have been observed in areas of the Lower Saint John River in close proximity to the proposed Project at Reversing Falls in Saint John, New Brunswick. Refer to Figure 64.

Location	Common Name	Species Name
DMK Wharf*	Green crab	<i>Carcinus maenas</i>
	Atlantic tomcod	<i>Microgadus tomcod</i>
	Rainbow smelt	<i>Osmerus mordax</i>
	Atlantic pollock	<i>Pollachius virens</i>
Spar Cove*	Herring	<i>Alosa spp.</i>
	Green crab	<i>Carcinus maenas</i>
	Sand shrimp	<i>Crangon septemspinosa</i>
	Banded killifish	<i>Fundulus diaphanous</i>
	Mummichog	<i>Fundulus heteroclitus</i>
	Atlantic silverside	<i>Menidia menidia</i>
	Atlantic tomcod	<i>Microgadus tomcod</i>
	White perch	<i>Morone americana</i>
Winter flounder	<i>Pseudopleuronectes americanus</i>	
Farry's Cove*	Herring	<i>Alosa spp.</i>
	American eel	<i>Anguilla rostrata</i>
	Fourspine stickleback	<i>Apeltes quadracus</i>
	White sucker	<i>Catostomus commersonii</i>
	Banded killifish	<i>Fundulus diaphanous</i>
	Mummichog	<i>Fundulus heteroclitus</i>
	Threespine stickleback	<i>Gasterosteus aculeatus</i>
	Atlantic silverside	<i>Menidia menidia</i>
	Atlantic tomcod	<i>Microgadus tomcod</i>
	Rainbow smelt	<i>Osmerus mordax</i>
Northern pipefish	<i>Syngnathus fuscus</i>	

NOTES:

*Data collected by Bethany Reinhart from fyke nets and seine trawls

3.2.5 Environmentally Significant and Managed Areas

The ACCDC query yielded eight Environmentally Significant Areas (ESAs) and five managed areas within 5 km of the Reversing Falls Mill (Figure 65), including:

- Manawagonish Island Important Bird Area (IBA);
- Saint's Rest Marsh and Beach IBA;
- Fern Ledges ESA;
- Greenhead Cave ESA;
- Reversing Falls and Outcrop Islands ESA;
- Saint John Cambrian-Precambrian Border ESA;
- Harbell's Cave ESA;
- Howe's Cave ESA; and
- Courtenay Forebay ESA.

Manawagonish Island is a 12 ha island about 1 km long × 250 m wide (Figure 65). The partially wooded island has rocky shores, coastal cliffs, and many small inlets. About 2 % to 3 % of the Atlantic Coast population of double-crested cormorants (*Phalacrocorax auritus*) inhabits the Island. This colony of *auritus* is among the three largest in the Maritimes. Herring gulls (*Larus sp.*), great black-backed gulls (*L. marinus*), and glossy ibis (*Plegadis falcinellus*) also nest on the Island. This is the only known Canadian breeding spot for *falcinellus*. Manawagonish Island and its associated satellite island Thumb Cap / Thrumcap Island are owned by the Nature Trust of New Brunswick.

Saint's Rest Marsh and Beach IBA (*a.k.a.*, the F. Gordon Carvell Nature Preserve) (Figure 65) is an internationally renowned bird-staging area as it is one of the largest salt marshes on the Bay of Fundy's north shore. Glossy ibis from Manawagonish Island are sometimes sighted there. Due to efforts of the Nature Trust of NB who erected several nesting platforms within the IBA, the great blue heron (*Ardea herodias*) population has been on the rise within the Marsh. A small peat bog is also found within this 49 ha IBA. Globally significant numbers (*i.e.*, > 1 % and > 3 %, respectively) of semipalmated sandpipers (*Calidris pusilla*) and semipalmated plovers (*Charadrius semipalmatus*) visit this IBA during the fall migration.

The Fern Ledges ESA (Figure 65) is located along the shoreline of Seaside Park in west Saint John between Bay Shore and Duck Cove. The site is significant for fossils. Rock outcrops there, which include exposures of Pennsylvanian gray sandstone and shale, are accessible at low tide. Most of the fossil-bearing beds worked in the 1860s are underwater. This site is the type locality for at least 40 species of fossils, particularly plant and invertebrate fossils, that are maintained in the New Brunswick Museum's collection.

Greenhead Cave is a cave located midway up a massive shoreline cliff on Green Head Island (Figure 65). A survey of the cave in 1978 reported a length of 64 m and a depth of 26.7 m. The majority of the Island is owned by the City of Saint John and has been labeled as an ESA as the Cave is used by bats as a hibernaculum. In the 1800s, the Island was the site of a lime quarry. Kiln foundations, wharf timbers, and foundation walls of homes still exist on the City-owned lands.

Three small bedrock islands, Goat Island (0.4 ha), Middle Island (0.5 ha), and Crow Island (0.3 ha), comprise the Reversing Falls and Outcrop Islands ESA (Figure 65). These Islands are owned by the Crown and are uninhabited. They exist at Reversing Falls / Rapids where the Saint John River flows through a narrow gorge before emptying into the Bay of Fundy. The rocks here form the contact of two ancient geologic terranes, Brookville and Caledonia, which are separated by the Caledonia Fault. This ESA and the Saint John Cambrian-Precambrian Border ESA are among the top 12 geosites within the Stonehammer Geopark. The majority of Uptown Saint John is built atop the contact between Cambrian and Precambrian age rocks. Outcrops are common throughout the Uptown.

The Saint John Cambrian – Precambrian ESA (Figure 65) represents the contact between the sedimentary rocks of the Saint John Group and igneous rocks from the early Cambrian period. The transition from Precambrian to Cambrian represents one of the most interesting times in the evolution of life; the sparse diversity of Precambrian life was suddenly replaced by an expansion of life forms representing almost every major group of taxa seen today. This ESA is a classic site for Cambrian fossils, such as trilobites, brachiopods, echinoderms, and other arthropods.

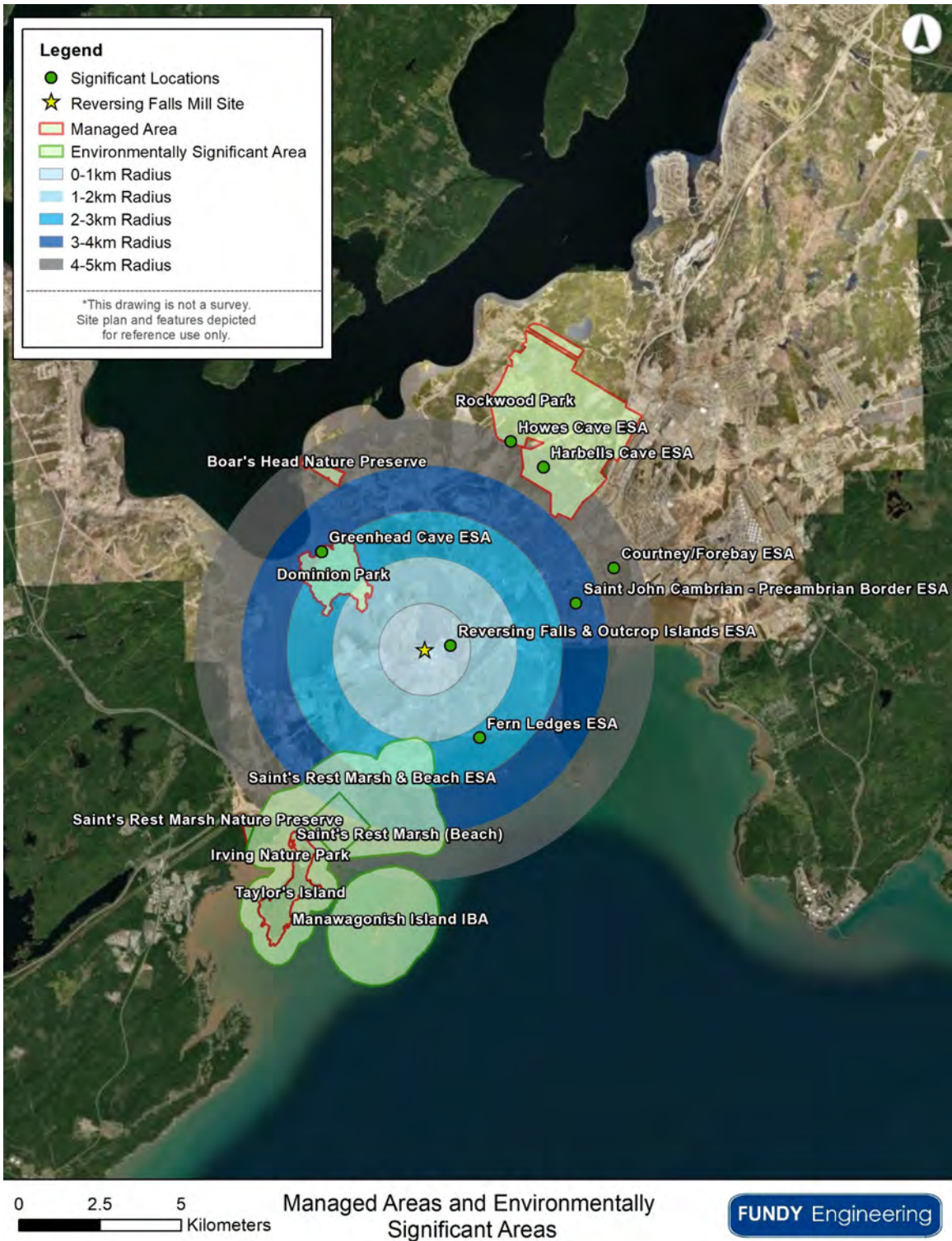

Figure 65. Map showing the environmentally significant and managed areas within a 5 km radius of the Reversing Falls Mill in Saint John, New Brunswick. Data obtained from the ACCDC.

The Harbell's Cave ESA and Howe's Cave ESA are both located within Rockwood Park (Figure 65). Both limestone caves are used by bats in the winter as hibernaculum.

Harbell's Cave is about 74 m long and has a stream with several waterfalls flowing through it and Howe's Cave is about 120 m long. Both caves are frequented by naturalists because of their ease of access and being within the Park.

The Courtenay Forebay ESA (Figure 65) is a significant area for waterfowl in Saint John. Bald eagles have also been observed preying on waterfowl within the Forebay. It is a unique 43 ha urban wetland that is frequented by birders. The Saint John chapter of the Atlantic Coastal Action Program has been a strong advocate for cleanup efforts related to the Forebay and Marsh Creek, which flows into the wetland.

The managed areas within 5 km of the Reversing Falls Mill include:

- Rockwood Park;
- Dominion Park;
- Boar's Head Nature Preserve;
- Saint's Rest Nature Preserve and Beach (also an ESA); and
- Irving Nature Park / Taylors Island.

Rockwood Park (Figure 65) is located entirely within Saint John and at 890 ha is one of Canada's largest urban parks. The park has an extensive network of trails that wind their way through the upland Acadian forest, over many hills, and around several freshwater lakes. Rockwood Park Golf Course is also located within the Park.

Dominion Park is located on Green Head Island (Figure 65). This Park is home to an urban, freshwater, sandy swimming beach. Because of the historic use of the area as a limestone quarry following the Great Fire of 1877, the area is part of the larger Stonehammer Geopark. It gives homage to one of the last historic lime kiln operations in southern New Brunswick.

Boars Head Nature Preserve (Figure 65) is managed by the Nature Trust of New Brunswick. It comprises 27 ha of land along 150 m of shoreline of Kennebecasis Bay near the confluence with the Saint John River. It is one of the last natural areas in the Millidgeville area of Saint John. The Preserve, which was formerly known as "The Farms" (*i.e.*, the Bullock family walked their cattle down a trail and into the nearby fields), contains red spruce groves, cedar and alder wetlands, and is home to the very rare *Anticosti* aster and the extremely rare maidenhair spleenwort.

The 243 ha Irving Nature Park (Figure 65) was created by JDI in 1992 to help protect an environmentally important area of southern New Brunswick. It is a peninsula of volcanic rock that has a long sandy beach along the Bay of Fundy side and a salt-marsh on the inland side. The area is a traditional staging area for birds migrating between the Arctic and South America. More than 250 species of birds have been observed during a single migration season. Eight walking trails on the island (*i.e.*, Taylor's Island) allow visitors to experience the area's fragile ecosystems. Upkeep, educational programs, and beautification of the Park are fully funded by JDI.

3.3 SOCIO-ECONOMIC ENVIRONMENT

3.3.1 Population and Demographics

In 2016, the population of the Saint John Census Metropolitan Area (CMA) was 126 202 [Statistics Canada, 2017]. Between 2011 and 2016, the population within the CMA decreased by 2.2 % from 129 057, a result of outmigration that was commonly felt throughout the Province in response to an economic downturn. As is common in most Canadian jurisdictions, the baby boomer generation (*i.e.*, 45 to 65 years old) is the dominant demographic (*i.e.*, $n = 38\,155$; Figure 66). Women represent a greater proportion of the population 25 years+ while men are the dominant group for those < 25 years old. More than 95 % of the population identifies English as their mother tongue.

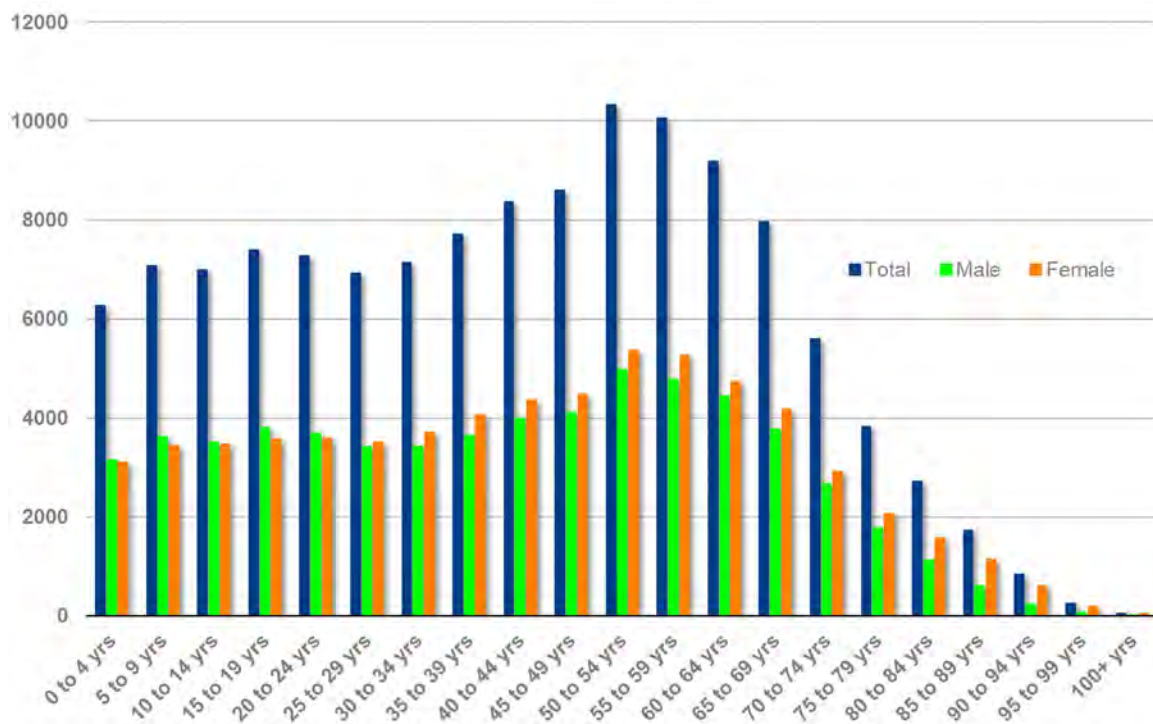

Figure 66. 2016 Statistics Canada demographics of the Saint John census metropolitan area.

At 3 510 km², the Saint John CMA represents about 4.9 % of New Brunswick's landmass. In 2016, the total number of private dwellings within the CMA was 58 398 and the average number of persons occupying each household was 2.3. Although there are urban, suburban, and rural areas of the CMA, residential development is considered scattered [Urban Strategies, 2011]. The population density was 36 persons · km⁻² in 2016.

3.3.2 Economy and Labour

In 2019, the Province's Gross Domestic Product (GDP) was \$30.7 billion chained to 2012 dollars [StatsCan, 2021a]. The labour force at that time was about 361 100 [StatsCan, 2021b]. New Brunswick has a resource-based economy that is largely dependent on

forestry, mining, and fishing. Tourism, agriculture, small-scale manufacturing, and a growing service sector provide balance and diversity. Real economic growth tends to be at or above the regional average for the Atlantic Provinces and is largely due to oil refining, telecommunications, computer software development, and natural gas distribution.

New Brunswick's monthly unemployment rate for January 2017 through to July 2021 is shown in Figure 67. Unemployment was its greatest in April 2020 when it hit 13.3%. At that time, approximately 47 200 people were unemployed. That high unemployment rate coincided with the onset of the global COVID-19 pandemic and when health security restrictions and measures were the most stringent. During the four and half year period shown, unemployment was at its lowest in July 2017 when it was 6.5%. At that time, 352 400 people were employed throughout the Province. The largest economic region for employment in New Brunswick is typically the southeast (*i.e.*, Albert, Westmorland, and Kent Counties).

The most recent labour force survey data available for Saint John are from 2016 [*Statistics Canada, 2017*]. A summary of the labour force by employment sectors is provided in Table 34. In 2016, the top five industries that employed people were: health care and social assistance; retail trade; construction; accommodation and food services; and administrative support, waste management, and remediation services. IPP employees would largely be considered part of the manufacturing sector (*i.e.*, some would be part of administrative support and management), which is the eighth greatest employment sector in Saint John.

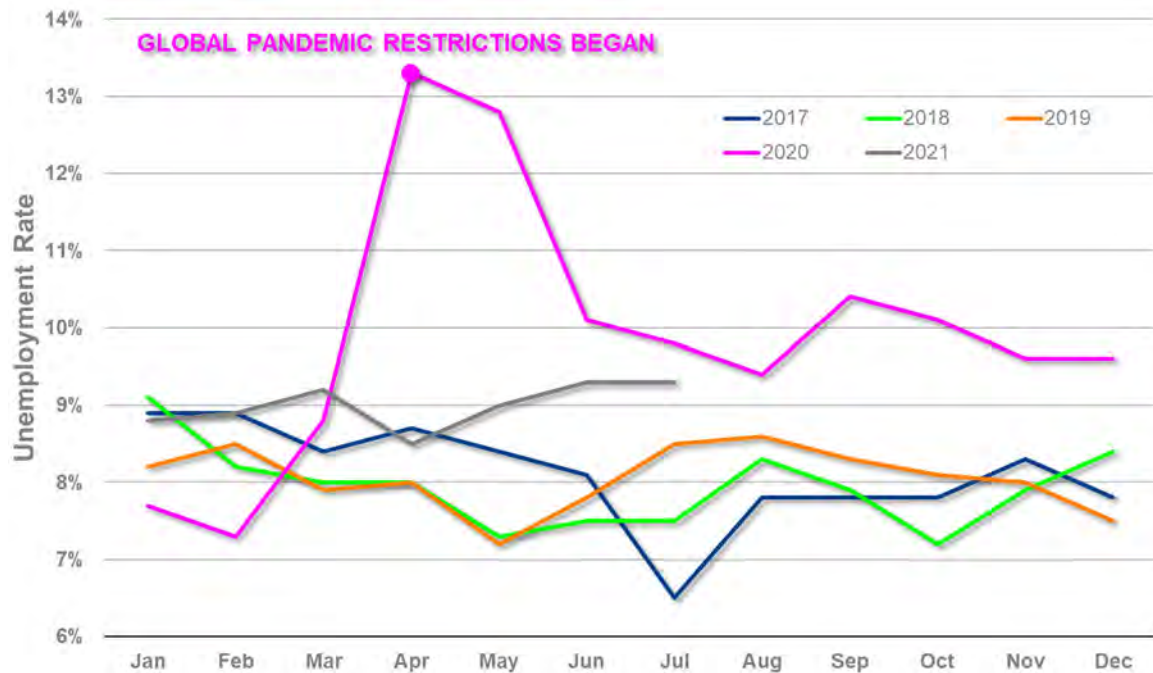

Figure 67. New Brunswick monthly unemployment rate between January 2017 and July 2021 based on data from New Brunswick Department of Labour and Statistics Canada.

Table 32. 2016 Statistics Canada labour force employment by sector for Saint John, New Brunswick.

Industry Sector*	Number of Employees	Percentage of Total Employees
Health care and social assistance	9 480	14.9
Retail trade	7 865	12.4
Construction	5 025	7.9
Accommodation and food services	4 360	6.9
Administrative and support, waste management, and remediation services	4 340	6.8
Professional, scientific, and technical services	4 195	6.6
Educational services	4 010	6.3
Manufacturing	3 990	6.3
Public administration	3 800	6.0
Other services, except public administration	2 985	4.7
Wholesale trade	2 625	4.1
Transportation and warehousing	2 625	4.1
Finance and insurance	2 430	3.8
Information and cultural services	1 390	2.2
Utilities	1 160	1.8
Arts, entertainment, and recreation	980	1.5
Real estate and rental and leasing	830	1.3
Mining, quarrying, and oil and gas extraction	765	1.2
Agriculture, forestry, fishing, and hunting	625	1.0
Management of companies and enterprises	85	0.1
	TOTAL	63 565
		100

NOTES: *North American Industry Classification System

The median total income for Saint John families (*i.e.*, two or more person households) in 2015 was \$81 243, which jumped 13 % from the \$70 610 median total income in 2011; however, > 17 % of the population are still considered low-income earners.

Saint John is located within the southwest economic region of New Brunswick, which encompasses Charlotte, Kings, and Saint John Counties (*i.e.*, 12 % of New Brunswick's land area). In 2011, the region was home to about 172 764 people (2011 Census) [NBDPSETL, 2013]. Saint John County where the Mill is located comprises Saint John, Simonds, Musquash, and Saint Martins, which represents about 44 % of the region's population (Table 33).

Table 33. Southwest New Brunswick Statistics Canada population data by County and Census Year.

County / Region	Area (km ²)	1991	1996	2001	2006	2011	2016	1991 to 2016 % Change
Saint John County	1 462	81 460	79 305	76 407	74 621	76 550	74 020	- 9.1
Charlotte County	3 424	26 610	27 335	27 366	26 898	26 549	25 428	- 4.4
Kings County	3 482	62 120	64 720	64 208	65 824	69 665	68 941	9.9
Southwest economic	8 368	170 190	171 360	167 981	167 343	172 764	168 389	1.1
New Brunswick	72 908	723 900	738 135	729 498	729 997	751 171	747 101	3.1

The southwest economic region has a relatively balanced economy [NBDPSETL, 2018]. Over one quarter of employment in the region is within the sales and service occupations (Table 34). Employment by industry sector is presented in Table 35 and shows that after the public sector is accounted for, the majority of individuals are employed in the sales and services sector. Some of the most significant private sector industries in the southwest economic region are trade, manufacturing, and construction.

Table 34. Employment by occupational category for the southwest economic region of New Brunswick in 2017.

Occupational Classification	Number of Employees	Percentage of Total Employees
Sales and service	23 600	28.0
Business, finance, and administration	14 800	17.6
Trades, transport, and equipment operators	11 100	13.2
Education, law and social, community and government	9 800	11.6
Management	6 500	7.7
Health	6 100	7.2
Natural and applied sciences and related	4 900	5.8
Manufacturing and utilities	4 000	4.7
Natural resources, agriculture, and related	2 600	3.1
Art, culture, recreation, and sport	900	1.1
TOTAL	84 300	100

Some of the largest employers in the southwest economic region are [NBDPSETL, 2013]:

- Horizon Health Network;
- Anglophone South School District;
- Bell Aliant;
- Irving Oil;
- J.D. Irving, Limited;
- Wyndham Worldwide Canada; and
- City of Saint John.

Table 35. Employment by sector for the southwest economic region of New Brunswick in 2017.

Industry Sector	Number of Employees	Percentage of Total Employees
Retail and wholesale trade	13 900	16.5
Healthcare and social assistance	12 700	15.1
Manufacturing	8 700	10.3
Business, building, and other support services	6 300	7.5
Educational services	5 400	6.4
Accommodation and food services	5 300	6.3
Construction	5 200	6.2
Professional, scientific, and technical services	4 500	5.4
Finance, insurance, real estate, rental, and leasing	4 200	5.0
Other services	3 800	4.5
Public administration	3 600	4.3
Natural resources	3 400	4.0
Transportation and warehousing	3 100	3.7
Information, culture, and recreation	2 500	3.0
Utilities	1 500	1.8
	TOTAL	84 100
		100

3.3.3 Archaeological and Cultural Features

Due to the historical industrial use of this land, the potential for significant archaeological and / or cultural resources to be present at the Project site is considered to be very low. However, because there is a remote possibility that a find could be made, the Project-specific EPP will explicitly identify the processes that must be followed by Project personnel in the event of a find.

Archaeological predictive modelling was requested for the Project site through the New Brunswick Department of Tourism, Heritage, and Culture. The results are presented in Figure 68. The information shows that a First Nations archaeological site (*i.e.*, BhDm-3) is located within 250 m of the Project site (*n.b.*, BhDm-3 is a previously disturbed site). The modelling also suggests that there is a high potential to encounter First Nations material adjacent to the Saint John River and remnants of historic settlement.

The Bentley Street Archaeological Site, which was designated as a protected archaeological site in 1998, is located nearby. The site has associations with about 4 000 years of First Nations history and thousands of artifacts have been recovered from the site. The artifacts collected suggest that the site was used for ceremonial purposes and was connected to sites at Portland Point and Marble Cove.

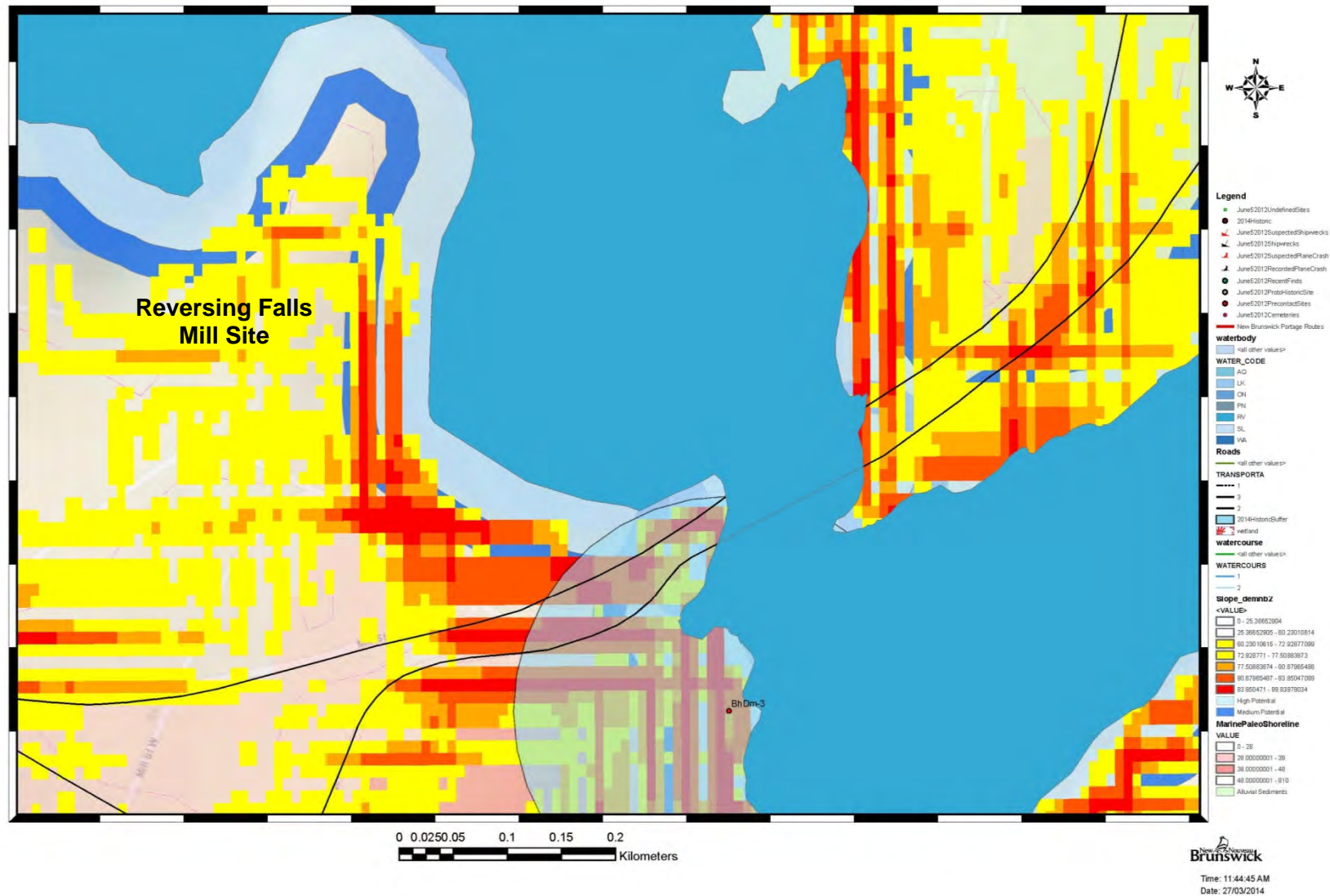

Figure 68. Archaeological predictive modelling in the vicinity of the Reversing Falls Mill Project site in Saint John, New Brunswick. Source: New Brunswick Department of Tourism, Heritage, and Culture.

3.3.4 Traditional Uses by First Nations

The history of the three First Nations is not widely known in New Brunswick; however, it is known that First Nations have occupied New Brunswick for time immemorial [Taylor, 2016]. The oldest site, just off the Marysville Bypass outside of Fredericton, confirms that First Nations lived on the land at least 12 000 years ago. The three First Nations that lived and survived off the lands are the Wolastoqiyik / Wəlastəkewiyik / Maliseet, the Mi'kmaq / Mi'kmaw, and the Passamaquoddy / Peskotomuhkati. They chose to settle in places near the plants and animals they depended upon for food, medicines, and sacred spiritual objects.

The Mill site is located adjacent to Reversing Falls (Gtchi-quaabeet-a-wi-cup-ahegan / great beaver's dam). Pawling [2017], notes that birchbark canoes, the traditional form of First Nations, could only run the Reversing Falls four times during a 24 hour period, probably for only 15 to 20 minute intervals during slack tide. If the tide was not optimal for traversing the falls, a short portage provided alternative access to the Bay of Fundy. A 1604 chart drawn by Samuel de Champlain of Saint John shows a portage route on the opposite side of the falls from the location of the existing Mill (Figure 69; extending from Marble Cove up and over the Douglas Avenue ridge to the Saint John Harbour). It is likely that was the route used by First Nations to navigate the falls (*i.e.*, near the New Brunswick Museum along Douglas Avenue and the Bentley Street Archaeological Site along Chesley Drive) [Raymond, 1905].



Figure 69. A copy of Samuel de Champlain's 1604 chart of the Saint John Harbour. From Raymond [1905].

Today, there are 15 First Nations communities in New Brunswick (Figure 70). The Brothers are located approximately 5 km to the North of the project site in the Kennebecasis River. Today, the islands are unoccupied, but traditionally they were used as seasonal campgrounds for hunting and fishing.

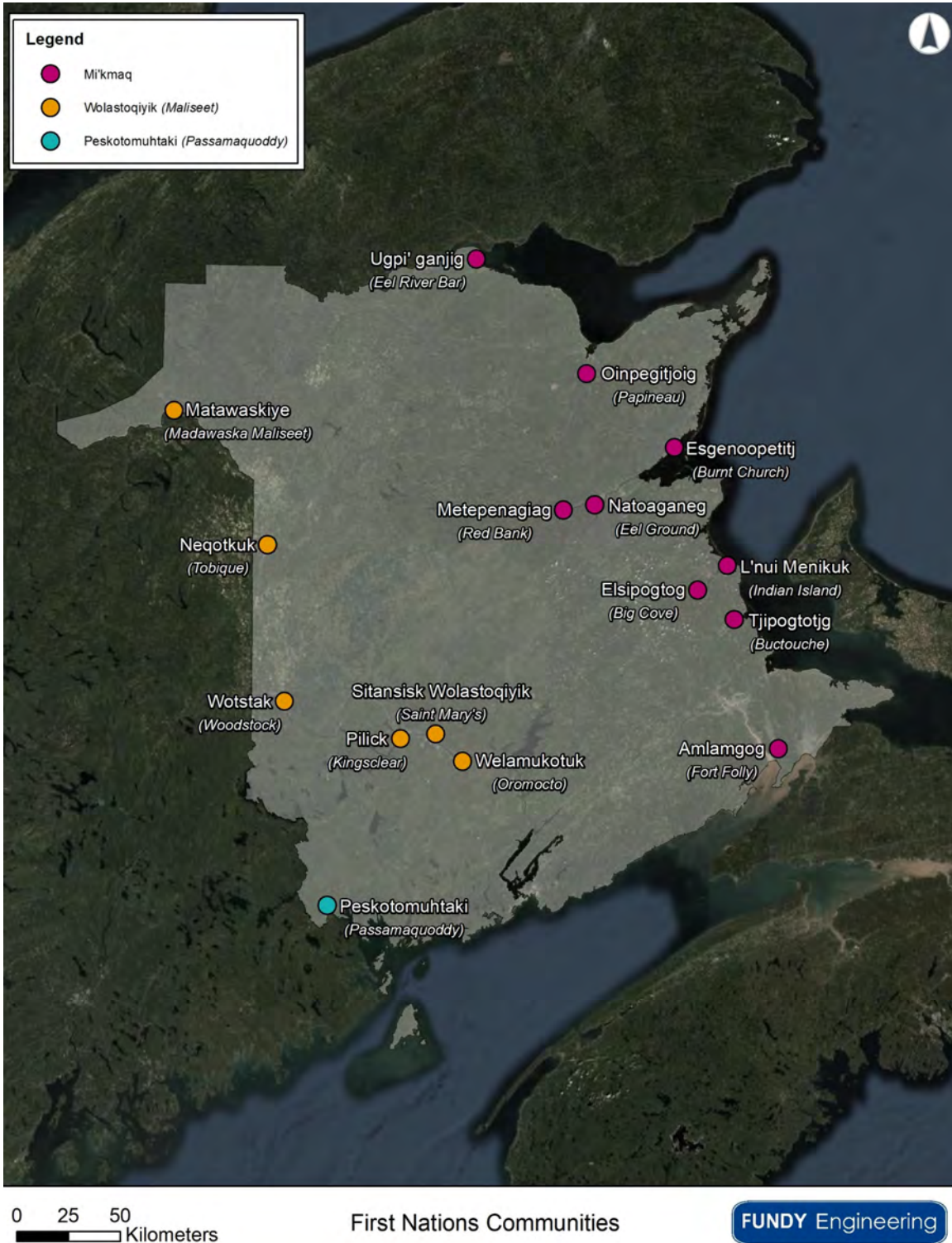

Figure 70. New Brunswick's First Nations communities.

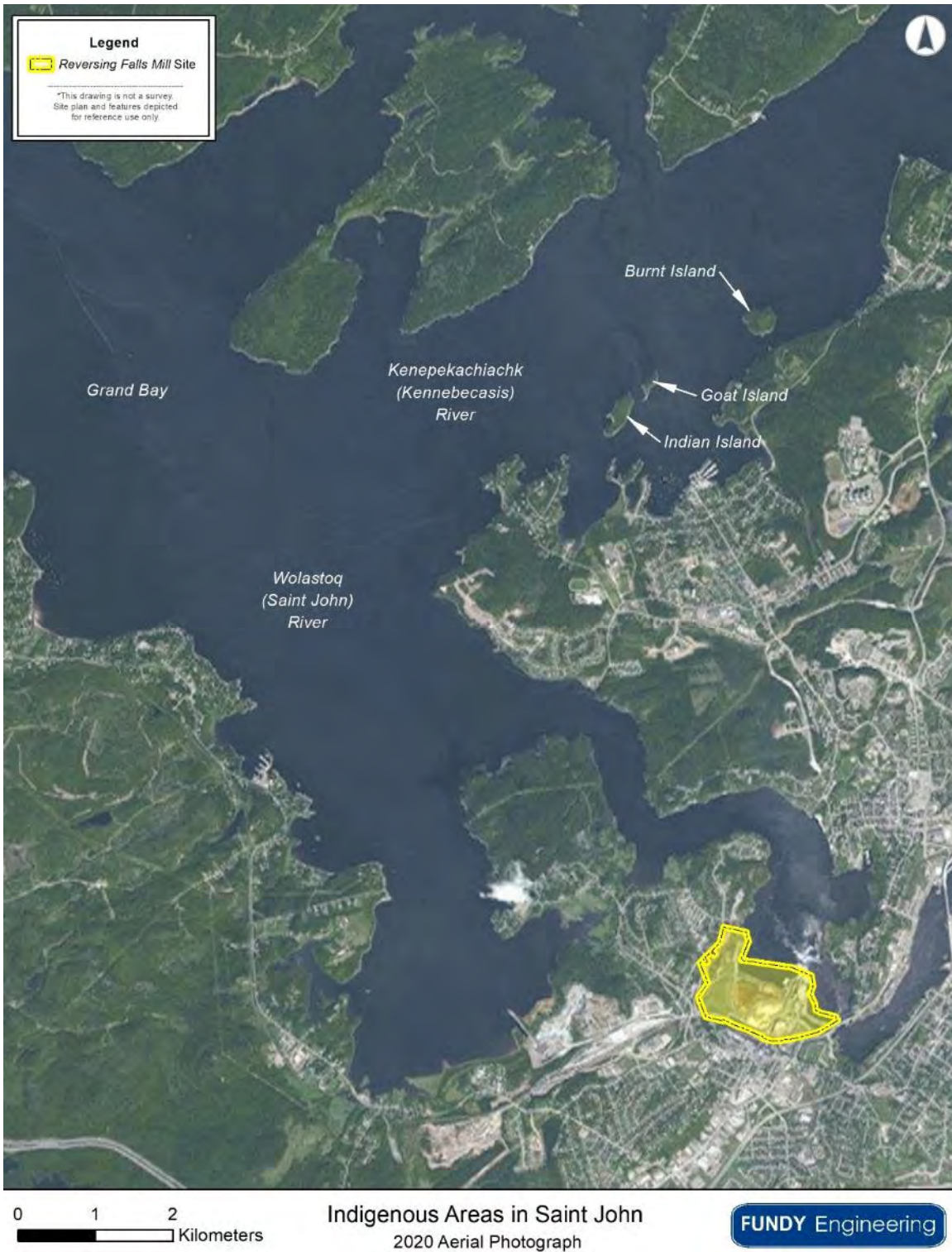

Figure 71. Aerial photograph showing the location of Goat Island, Indian Island, and Burnt Island in relation to the Reversing Falls Mill in Saint John, New Brunswick.

3.3.5 Historical Land-Use

The point of land the Mill sits atop was known historically as Union Point, which is located within Lancaster Parish of Saint John County. Since the mid- to late-1800s, the site has been home to heavy industrial activities related to pulp and paper making. The Provincial Archives of New Brunswick does note that in 1866, Union Point had 55 families. It is inferred that those families were present for the operation of the local mill. The settlement of Union Point Road, located nearby, had six resident families at that time. Information on Union Point is scant; however, what information could be compiled from historical references is provided below and summarized in Table 36. What is clear is that Union Point has been the site of industrial activity for > 175 years. Previous mills have burned down while others endured financial hardships. At 70 years+, IPP has been present at the site the longest.

Table 36. Historical timeline of the use of the Union Point lands, now known as the Reversing Falls Mill in Saint John, New Brunswick.

Year	Description
<u><i>Cunnabells Sawmill</i></u>	
1836 / 1837	➤ St. John Mills and Canal Company constructed and operated the Cunnabells Sawmill at Cunnabelle Point (Union Point)
1850	➤ Colonel John E. Goddard (1811-1870) purchased the Cunnabells sawmill and operated it with his son Charles W. (1844-?)
<u><i>Andre Cushing and Company Mill</i></u>	
1852	➤ Brothers Theophilus (1802-1881) and Andre Cushing (1820-1891) purchased the Cunnabells sawmill and renamed it the Andre Cushing and Company Mill, a steam sawmill with four grates for manufacturing pine lumber for US markets
1855	➤ Fire destroyed the sawmill ➤ The sawmill was rebuilt ➤ Started manufacturing sugar box shooks and cheaper qualities of lumber for the West India market
1857	➤ Theophilus's son George Byron Cushing (1831-1888) became a partner in the firm
1861	➤ Theophilus retired and transferred his interest in the firm to his son George
1869	➤ Fire destroyed the sawmill ➤ The sawmill was rebuilt
10 April 1895	➤ Fire completely destroyed the sawmill that employed about 250
<u><i>Andre Cushing and Company Mill and Cushing Sulphite Fibre Company</i></u>	
1896	➤ The sawmill was rebuilt and the Cushing Sulphite Fibre Company was co-located at the site to process waste from the mill ➤ Together, the two companies employed approximately 550 people
<u><i>Saint John Pulp & Paper Company</i></u>	
Circa 1900s	➤ Saint John Pulp & Paper Company, with operations at Mispesc Point, purchased the mills at Union Point
<u><i>Partington Pulp & Paper</i></u>	
1911	➤ English Industrialist Edward Partington (1836-1925), the first Baron of Doverdale, purchased the Saint John Pulp & Paper Company and rebranded it as the Partington Pulp & Paper
1913	➤ Machinery (two small digesters, a pulp drying machine, screens, etc.) was moved from the pulp and paper operations at Mispesc Point to the Union Point mill

Year	Description
<u><i>Nashwaak Pulp and Paper Company</i></u>	
1916	<ul style="list-style-type: none"> ➤ Bryant Paper Company and the Oxford Paper Company purchased the Edward Partington Pulp and Paper Company and operated as the Nashwaak Pulp and Paper Company ➤ Daily sulphite production capacity was 120 tons
1930	➤ The Nashwaak Pulp and Paper Company was shuttered
<u><i>Port Royal Pulp & Paper Co. Ltd.</i></u>	
1932	➤ Brothers Edward Lacroix (1889-1963) and Charles Lacroix of Quebec purchased the shuttered Mill
1933	➤ The Mill reopened under the name Port Royal Pulp & Paper Co. Ltd.
<u><i>Saint John Sulphite Ltd.</i></u>	
1946	➤ K.C. Irving (1899-1992) purchased Port Royal Pulp & Paper Co. Ltd. when it fell into financial troubles and initially operated as Saint John Sulphite Ltd.
<u><i>Irving Pulp & Paper, Limited</i></u>	
1951	<ul style="list-style-type: none"> ➤ Saint John Sulphite Ltd. renamed to Irving Pulp & Paper, Limited (IPP) ➤ IPP has continuously operated the Reversing Falls Mill since 1946 ➤ Present production is 1 000 Air Dry Metric Tonnes per day of pulp and employees number ~ 350

Since its purchase by IPP, the Mill has undergone many upgrades and expansions to remain globally competitive. A 1953 aerial photograph of the site shows the existence of some residences on the swath of land between the railroad tracks and the Mill where the Tissue Plant currently exists (Figure 72). The Mill underwent expansion following the purchase by IPP. Lands were acquired for the expansion, which included residential lots.

Aerial photographs of the Mill since being taken over and operated by IPP are shown in Figure 73 through Figure 76. The photographs show progressive expansion of the Mill site, primarily through development of previous residential and vacant lands towards the railway tracks.



Figure 72. Aerial photograph, circa 1953, of the Reversing Falls Mill in Saint John, New Brunswick.



Figure 73. Aerial photograph, circa 1962, of the Reversing Falls Mill in Saint John, New Brunswick.



Figure 74. Aerial photograph, circa 1976, of the Reversing Falls Mill in Saint John, New Brunswick.



Figure 75. Aerial photograph, circa 1984, of the Reversing Falls Mill in Saint John, New Brunswick.



Figure 76. Aerial photograph, circa 1994, of the Reversing Falls Mill in Saint John, New Brunswick.



Figure 77. Aerial photograph, circa 2011, of the Reversing Falls Mill in Saint John, New Brunswick.

3.3.6 Health and Safety

Started in 1849, the Saint John Police Force (SJPF) is one of the Canada's oldest police departments. The SJPF has about 140 sworn and 50 civilian members [EY, 2020]. Services the SJPF provides are: victim services and service planning; crime prevention; emergency response (e.g., 911, emergency tactical services, canine, etc.); law enforcement (e.g., patrol, criminal investigations, traffic, integrated intelligence, etc.); and public order (e.g., by-law enforcement).

Typically, the SJPF handles 55 000 calls annually of which between 3 500 and 4 000 are offences (i.e., violent crimes and property crimes combined). The SJPF is headquartered at One Peel Plaza in the heart of Saint John, but does operate some community police offices in priority neighbourhoods of the City.

The Saint John Fire Department (SJFD) has been operating in the City since 1786. The SJFD focuses on reducing the loss of life, personal injury, property damage, and impact on the environment caused by fire, accident, medical emergency, and hazardous materials release. Some of the many services the ~ 165 member SJFD provides include: fire rescue and suppression; technical rescue; hazardous materials emergency response; fire prevention; fire investigation; and medical first response [EY, 2020].

Existing in Canada's oldest incorporated city that is the most industrialized in eastern Canada, the SJFD strategically focuses on developing their response to support high risk industrial operations, including refining, processing, manufacturing, and energy related industries. The SJFD responds to around 5 000 calls annually of which about 60 % are medical calls [EY, 2020]. Saint John's fire service is operated from six stations scattered throughout the City.

Saint John has an Emergency Management Organization (EMO), which is dedicated to emergency preparedness, mitigation, response, and recovery for both natural and anthropogenic disasters. The goal of the EMO is to minimize the impact of emergencies on residents, property, and environment. Major emergencies the EMO prepares for include: floods; wind storms; power outages; severe storms; storm surges; wild fires; disease outbreaks; and hazardous materials.

Ambulance New Brunswick (ANB) provides land and air ambulance services throughout New Brunswick. ANB's team comprises more than 1 000 health care professionals, including primary care paramedics, emergency medical dispatchers, and critical care flight nurses.

The Reversing Falls Mill is a heavy industrial site. Approximately 480 people are employed at the Mill for routine operations (n.b., many more people are employed during regular operation and maintenance programs). As described in Section 2.8.2.8, a detailed and site-specific health and safety program is in place at the Mill.

3.3.7 Transportation Network and Links

Saint John is strategically located on a natural harbour about 100 km from the US border and within 48 hours travel to major markets in central Canada and the Atlantic seaboard. Because of its location, Saint John is a gateway for trade to the Maritimes, Atlantic markets

in North and South America, and Europe. Various components of the transportation network and their links are described below.

Saint John has an intricate web of roadways. A network of provincial and municipal roads provides access to the Mill site. The Saint John Throughway (*i.e.*, NB Route 1) is a four-lane divided highway that is maintained by Transfield Dexter Gateway Services Ltd. Municipal roads, such as Bridge Road and Chesley Drive (*i.e.*, together forming NB Route 100) are two-lane asphalt roads that are maintained by the City of Saint John. Within the Mill site, there is a series of private roads, which are maintained by IPP, for accessing specific areas (*i.e.*, Mill Street, Mill Cove Road, and Woodyard Road). All of the roadways described above are designed for heavy truck traffic and / or are truck routes (Figure 78).

Port Saint John, Atlantic Canada's largest port by volume, has major international port facilities at the head of Saint John Harbour near the mouth of the Saint John River (Figure 78) [PSJ, 2020]. The Port of Saint John is a recognized port of national significance and one Canada's marine gateways for domestic and international trade and tourism. Port Saint John's facilities are linked to major railroads and highways.

The Port has several berths capable of supporting a wide variety of vessels and there are several expansive laydown areas within the Port's land holdings. There is also a wide range of facilities to handle all types of cargo and is essential to some of New Brunswick's major industries. The Port's diversified operations cross six business sectors: liquid bulk; dry bulk; break bulk; containers; cruise; and indirect marine-related activities [PSJ, 2020].

In 2020, the Port processed 25.9 million metric tonnes of cargo and 79 179 twenty-foot equivalent unit containers [PSJ, 2020]. Liquid bulk represents the largest cargo and is typically > 95 % of the annual cargo. Cargo levels peaked in 2017, fell in 2018 and have continued to rise since. Container numbers and number of vessel calls increased in 2017 when DP World Saint John took over operations at the cargo terminal. Cruise ship traffic was suspended in Canadian waters by Transport Canada in 2020 due to the global COVID-19 pandemic. As a result, Port Saint John has experienced no cruise visits since 1988. In 2019, 79 cruise ships with a total of 196 032 guests called on the Port.

In partnership with the Government of Canada and the Province of New Brunswick, Port Saint John is undergoing a seven year, \$200 million+ West Side Modernization Project. The project will see much needed infrastructure upgrades at the Port's west side terminal. When complete in 2023, the longer, stronger pier, a 4.9 m deeper berth, and a 40 m wider channel will ensure Port prosperity and regional growth for years to come by having the ability to accommodate the New Panamax container vessel size). Annual throughput capacity is anticipated to double as a result and proper handling capabilities will be in place to service modern shipping fleets.

The Canadian National (CN) railway, which is the sole Class 1 Railroad in Atlantic Canada, and New Brunswick Southern Railway (NBSR) both serve Saint John. The NBSR has long line connections to CN, Canadian Pacific, Pan Am, and Maine, Montreal, Atlantic into the Maritimes, Central Canada, the US East Coast and the Midwest. Transit times for most locations are about a week or less.

The Mill is serviced with rail by NBSR, which is also a division of JDI. Direct rail connections to other Atlantic Provinces and the US northeast are made via the NBSR. There are several spur lines into the Mill site (Figure 78). One of the spur lines is dedicated

to woodchip unloading from rail cars while other spurs are used for delivering pulping chemicals and other process input materials and for exporting Kraft pulp.



Figure 78. Map showing truck, railway, and port connections to the Reversing Falls Mill in Saint John, New Brunswick.

The Saint John Airport, YSJ, is located in east Saint John about 15 km northeast of the City's centre. The airport has two asphalt runways; runway 05 / 23 is 2 195 m long and runway 14 / 32 is 1 554 m long.

As a gateway to Canadian and trans-border destinations, YSJ is serviced by six airlines: Air Canada; Porter; Sunwing; Flair; Atlantic Charters; and PAL airlines. In 2018, the passenger count through YSJ was about 282 000. Medevac flights, cargo, and private carriers also use the airport daily. Although not a major cargo handling facility, Air Canada Cargo does process, store, and ship cargo at YSJ.

3.3.8 *Municipal Services and Infrastructure*

The City of Saint John provides many municipal services, including water and sanitary sewer, police and fire, transit, recreation, and many others. The core municipal services provided by the City of Saint John are described in more detail below.

Saint John Water (SJW), a department of the City of Saint John, is responsible for the delivery of water and sewer services within the City. SJW provides quality potable water and industrial water to all connected users within the City. Potable water conforms to the Water Quality Regulation [82-126] of the New Brunswick *Clean Environment Act* [R.S.N.B. 1973, c. C-6] and the Potable Water Regulation [93-203] of the New Brunswick *Clean Water Act* [S.N.B. 1989, c. C-6.1]. In Saint John, potable water receives treatment; coarse screening, chemical treatment and filtration, disinfection, and fluoridation. Industrial water is water that has not been treated.

The City of Saint John has an extensive water network with over 510 km of distribution and transmission water pipes [EY, 2020] (Figure 79). Potable water is primarily sourced from the Loch Lomond surface water system in the east and the Southbay groundwater system in the west (*n.b.*, there is also a small wellfield in Red Head for residents of the Harbourview Subdivision). Industrial water is sourced from Spruce Lake in the west and Loch Lomond in the east.

Wastewater is collected from residential, commercial, and industrial clients within the City and transported to treatment plants through an extensive network of sewer lines and pumping stations. SJW operates seven wastewater treatment facilities, 38 wastewater pumping stations, and 510 km of sanitary and storm sewers in the City (Figure 79). Through the implementation of *Harbour Cleanup*, the City of Saint John has treated all of the sanitary waste collected within the City since 2006 before discharge to a receiving water body, such as the Bay of Fundy.

Potable water, industrial water (*i.e.*, process water), and fire water at the Mill are all supplied by the City of Saint John. Sanitary waste generated at the Mill is sent to the municipal collection system.

The City of Saint John has a residential solid waste management program only. Garbage, compost, and recyclables are collected and transported by truck to the Crane Mountain Landfill operated by the Fundy Region Solid Waste Commission. Multi-unit residences (*i.e.*, five or more units), commercial properties, and industry are responsible for their own solid waste management, which is generally contracted through one of several waste management haulers (*e.g.*, GFL Saint John, Fero Waste & Recycling, *etc.*). The Mill has contracts in place whereby solid waste is transported to the Crane Mountain Landfill and

compostable materials that are not burned in the biomass boiler are sent to facilities such as Envirem Organics Inc.

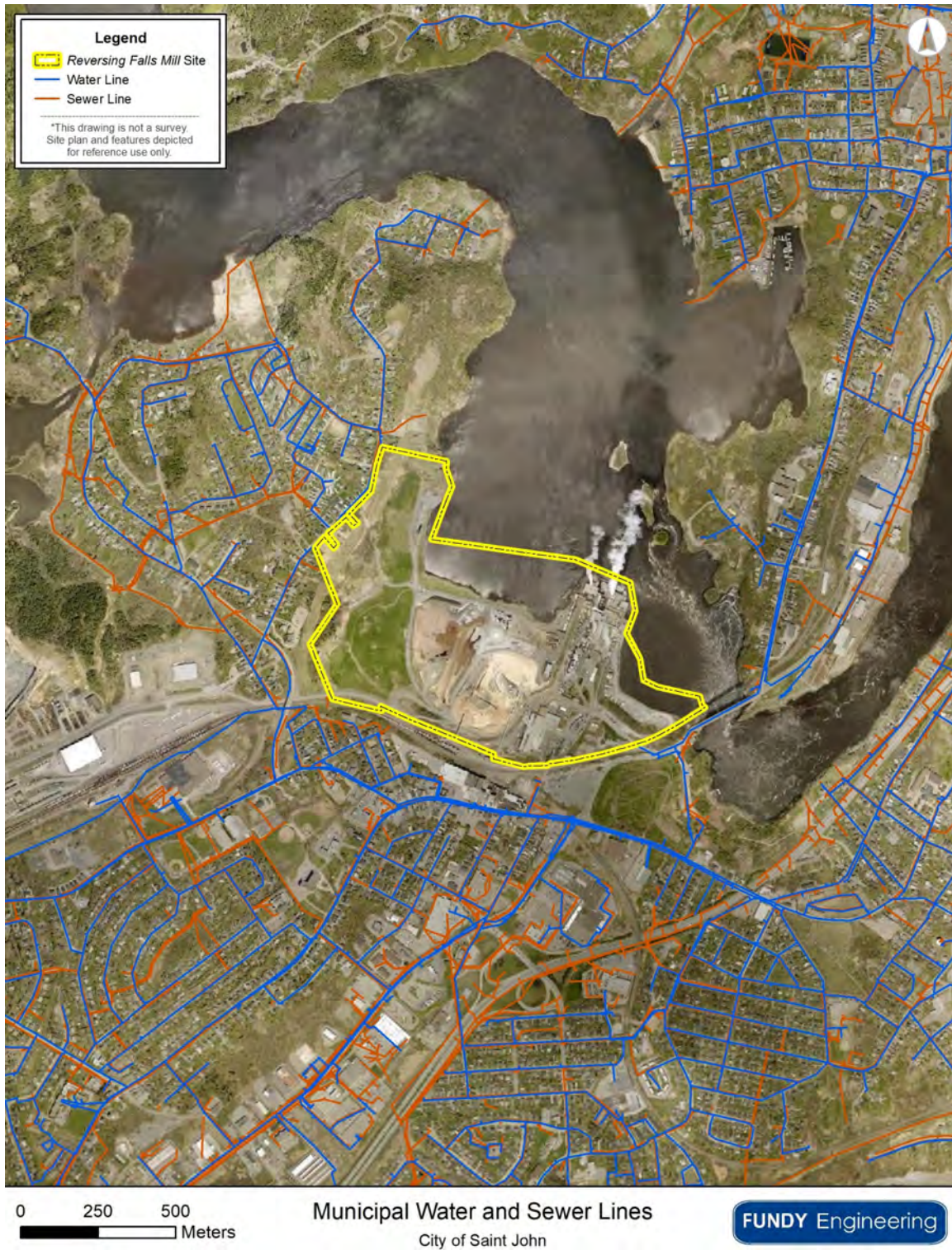

Figure 79. Aerial photograph showing the major municipal waterlines and sewer lines in the vicinity of the Reversing Falls Mill in Saint John, New Brunswick.

The Saint John Transit Commission (SJTC) was established in 1979 to provide scheduled transit service throughout the City. The SJTC also has scheduled service to some outlying communities through the COMmunity EXpress (COMEX) service. As the largest public transit system in New Brunswick, the SJTC has a ridership of about 2.1 million passengers annually. On average, ridership is 50 % higher for the SJTC when compared to other Canadian cities with a population between 50 000 and 150 000.

3.3.9 Aesthetics

As Canada's first incorporated city, Saint John has a rich collection of historic buildings. It is a city that has largely built out, not up; in 2011, the population across the 316 km² City was only 70 063 [*StatsCan*, 2013]. Only a few tall office buildings (e.g., Bell, Brunswick House, City Hall, Irving Oil Home Office, JDI, etc.) and churches (e.g., Saint John's Anglican Stone Church, Trinity Church, St. Andrew and St. David, etc.) dominate Uptown Saint John's skyline (Figure 80). Saint John's east-side and west-side skylines are dominated by long-lived industries that are major employers of residents. To the east are industries such as Bayside Power, the Saint John Refinery, and Irving Paper while to the west are industries such as Moosehead Breweries and the Mill.



Figure 80. Panoramic photographs showing the skyline of east Saint John, Uptown Saint John, and west Saint John, New Brunswick.

3.3.10 Recreation and Tourism

The Mill site is a private and secure facility. It is not part of any International, National, Provincial, or Municipal park. It does not comprise a migratory bird sanctuary, ecological reserve, wildlife management area, wildlife refuge, or game sanctuary. The site is not protected environmentally in any manner (*i.e.*, protected watershed, wellfield protection zone, and / or protected natural area). This was confirmed through information reviewed within the ACCDC databases and mapping available from the NBDNRED, the NBDELG, and the City of Saint John.

Hundreds of thousands of people are drawn to the region each year for the rich urban architecture, the region's natural beauty, and the unique maritime culture. A cruise ship business began in 1989 when a ship was forced into port during a hurricane. Since then, more than two million passengers have called on Saint John. There are many attractions that tourists are encouraged to visit as shown in Figure 81. According to *Discover Saint John*, the top attractions are the Reversing Falls / Rapids, the Saint John City Market, and the New Brunswick Museum. In addition to visiting Reversing Falls to view the natural beauty, people also kayak and fish for striped bass.



Figure 81. Several tourist attractions in the vicinity of the Reversing Falls Mill in Saint John, New Brunswick.

Saint John has several National Historic sites that lure tourists. Those sites include:

- Carleton Martello Tower;
- Fort Howe;
- Fort La Tour;
- Loyalist House;
- Saint John City Market; and
- St. John's Anglican Stone Church.

4.0 POTENTIAL ENVIRONMENTAL IMPACTS AND MITIGATION

4.1 ENVIRONMENTAL IMPACT ASSESSMENT PURPOSE

The concept of Environmental Impact Assessment was first developed in the United States as a result of the *National Environmental Policy Act* of 1969 (*NEPA*) [Wood, 1995], which was enacted on 1 January 1970. Today, *NEPA* is considered the environmental *Magna Carta* [CEQ, 2021]. Several celebrated cases in the United States, such as the Tocks Island Dam and the Cross-Florida Barge Canal [ELI, 2010], clarified the significance of the *NEPA* and focused international attention on EIAs. The United Nations Conference on the Human Environment held in Stockholm from 5 to 16 June 1972, also known as the 1972 Stockholm Conference, introduced a framework for environmental action [UNEP, 1973].

EIA was introduced in Canada with the passing of a federal cabinet directive in 1973 for the Environmental Assessment Review Process (EARP) [Wood, 1995]. In 1975, New Brunswick became the first Atlantic province to adopt the formal Cabinet EARP policy [NBDELG, 2018]. That policy covered all major development proposals that the Government and / or its various agencies have significant financial involvement. During the late 1970s and early to mid-1980s, the Province reviewed, amended, and revised their EIA statutory framework.

On 13 July 1997, the Environmental Impact Assessment Regulation [87-83] was enacted under New Brunswick's *Clean Environment Act* [R.S.N.B. 1973, c. C-6], which is administered by the NBDELG. Under [87-83], any individual, private firm, or government agency that proposes a project listed under "Schedule A" that may impact the environment must formally register the project for EIA review with the NBDELG. The proponent is responsible for generating and subsequently submitting an EIA registration document that satisfies the requirements of the NBDELG [2018] guide to EIAs.

The EIA process is used as a planning tool under which the environmental impact potentially resulting from a proposed project is identified and assessed early in the planning process. EIA is an anticipatory and participatory process that involves identifying measures that can be taken to avoid negative environmental impacts or reduce them to acceptable levels well in advance of their occurrence. EIAs need to be of sufficient length and breadth to ensure that the underlying decision about whether or not a project can move forward and can be adequately evaluated by regulatory authorities, stakeholders, and the general public.

In New Brunswick, the EIA process is considered a proactive and preventative approach to environmental management and protection. The NBDELG realizes that the proponent has likely only completed preliminary project design at the time of EIA review. Detailed design can occur following EIA approval and so long as any modifications made yield the same or reduced potential environmental impacts, they are acceptable. Any modifications that have the potential to yield additional environmental impacts may require additional review and approval.

Although not unique, New Brunswick has its own distinctive EIA process. Under that process, there are two types of EIA review: a Determination Review; and a Comprehensive Review. All Projects registered under the EIA Regulation are required to

undergo a Determination Review. Less than 0.1 % of previously registered projects with the NBDELG have triggered a Comprehensive Review. It is presumed that this Project will be evaluated under a Determination Review. The step-wise systematic review process of the Determination Review is shown in Figure 82.

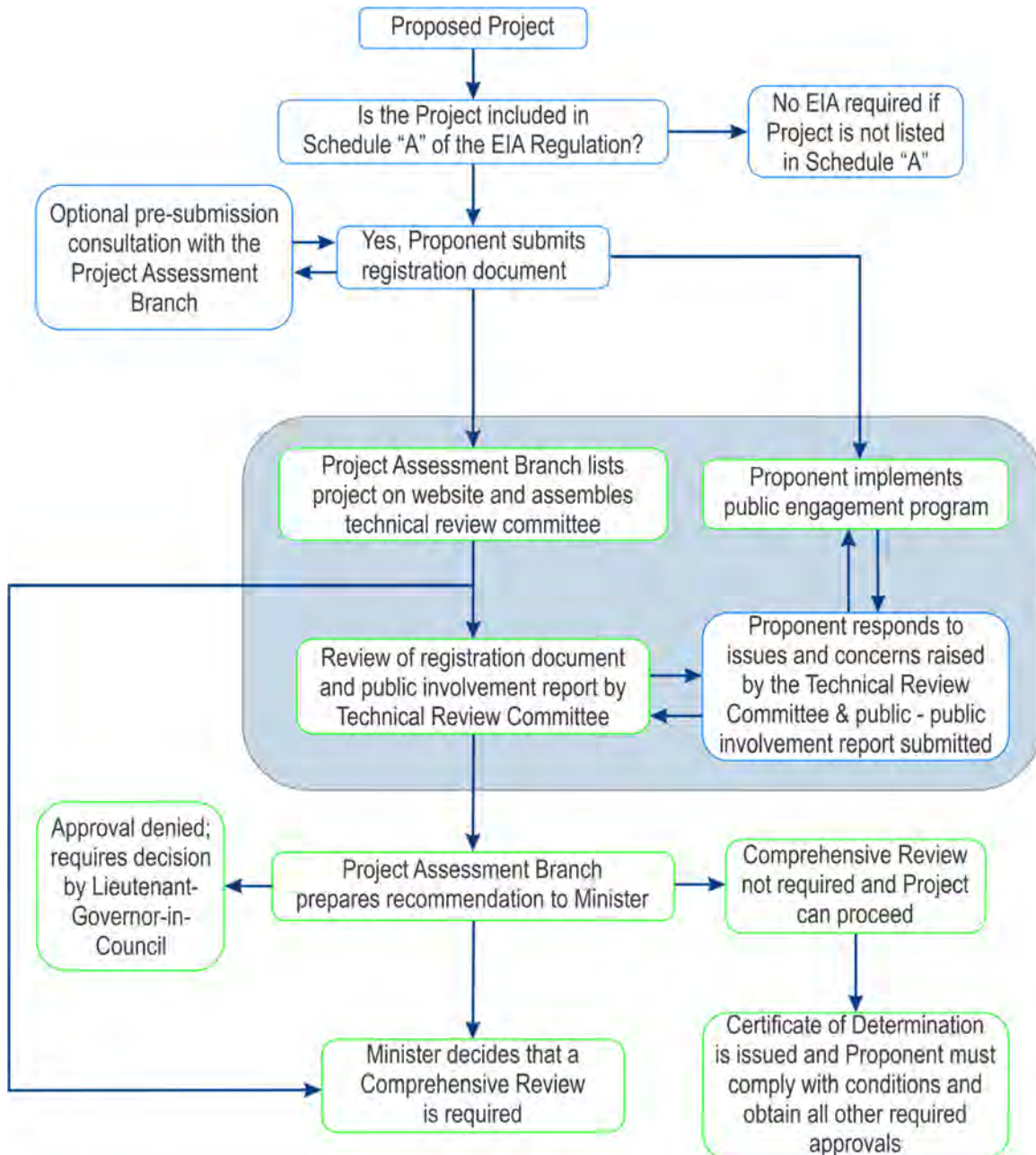

Figure 82. The New Brunswick Department of the Environment and Local Government's Environmental Impact Assessment (EIA) step-wise determination review process highlighting the public consultation component of the process (*i.e.*, the blue box). Source NBDELG [2018].

4.1.1 Guiding Principles

The guiding principles of EIA good practice are presented in Table 37. Within this EIA, the principles are considered together while recognizing their varying interrelationships.

Table 37. The guiding principles of environmental impact assessment. After Sadler [1996] and IAIA & IEMA [1999].

Principle	Application
Purposive	Achieves the goal of informing decision makers and ensures an appropriate level of environmental protection and human health
Focused	Concentrates on the significant environmental impacts and accounts for issues that matter
Adaptive	Adjusts to the realities, issues, and circumstances of the project under review
Participative	Provides appropriate opportunities to inform and involve rightsholders, stakeholders, and the public while accepting their input and addressing their issues and concerns
Transparent	Is clear, easily understood, and in an open process with early notification procedures, access to documentation, and a public record of decisions taken and reasons for them
Rigorous	Applies best practicable methodologies to address the impacts and issues being assessed
Practical	Identifies measures for impact mitigation that work and can be implemented
Credible	Is carried out with professionalism, rigor, fairness, objectivity, impartiality, and balance
Efficient	Imposes minimum cost burden on proponents consistent with meeting process requirements and objectives

4.2 ENVIRONMENTAL IMPACT AVOIDANCE

Sustainable development is an evolving concept that first gained traction with the release of the *Brundtland* [1987] report. In that, sustainable development was defined as development that meets the needs of today's generation without compromising those of future generations. Much of EIA today is concerned with preventing, mitigating, and offsetting significant adverse effects in order to accommodate the needs of the environment for subsequent generations.

Reducing the burden of environmental impacts is necessary if development is to become sustainable. Therefore, a preference hierarchy (Figure 83) is typically applied to environmental impacts. Although not always possible, impact avoidance is the preferred choice for project development. Avoidance can sometimes be achieved by choosing an alternate project, selecting an alternative project design, implementing environmentally sustainable technologies, or picking an alternate development site.

Mitigation must occur when avoidance is not possible and is the reduction of adverse effects of development at all project stages to the smallest degree possible and must always be undertaken when impacts are present. Proposed mitigation, which includes preventing pollution, minimizing physical disturbances, good-housekeeping, creative land management, technological fixes, *etc.*, must be realistic and effective, and where possible, based on best-practices.

Compensation should only be considered after all other options have been duly addressed. It attempts to 'make up' for or 'offset' unavoidable impacts, which is required in some instances. For example, the *Fisheries Act* [R.S.C., 1985, c. F-14] requires a "no-

net-loss” of fish habitat whereby altered, disturbed, or destroyed habitat must be offset by reclaiming, enhancing, or creating habitat elsewhere.

Mitigation and compensation play an important role in the EIA process. Through the planning process, measures can be developed to:

- enable better protection of environmental features and components;
- encourage the prudent use of natural resources; and
- avoid costly environmental damage.

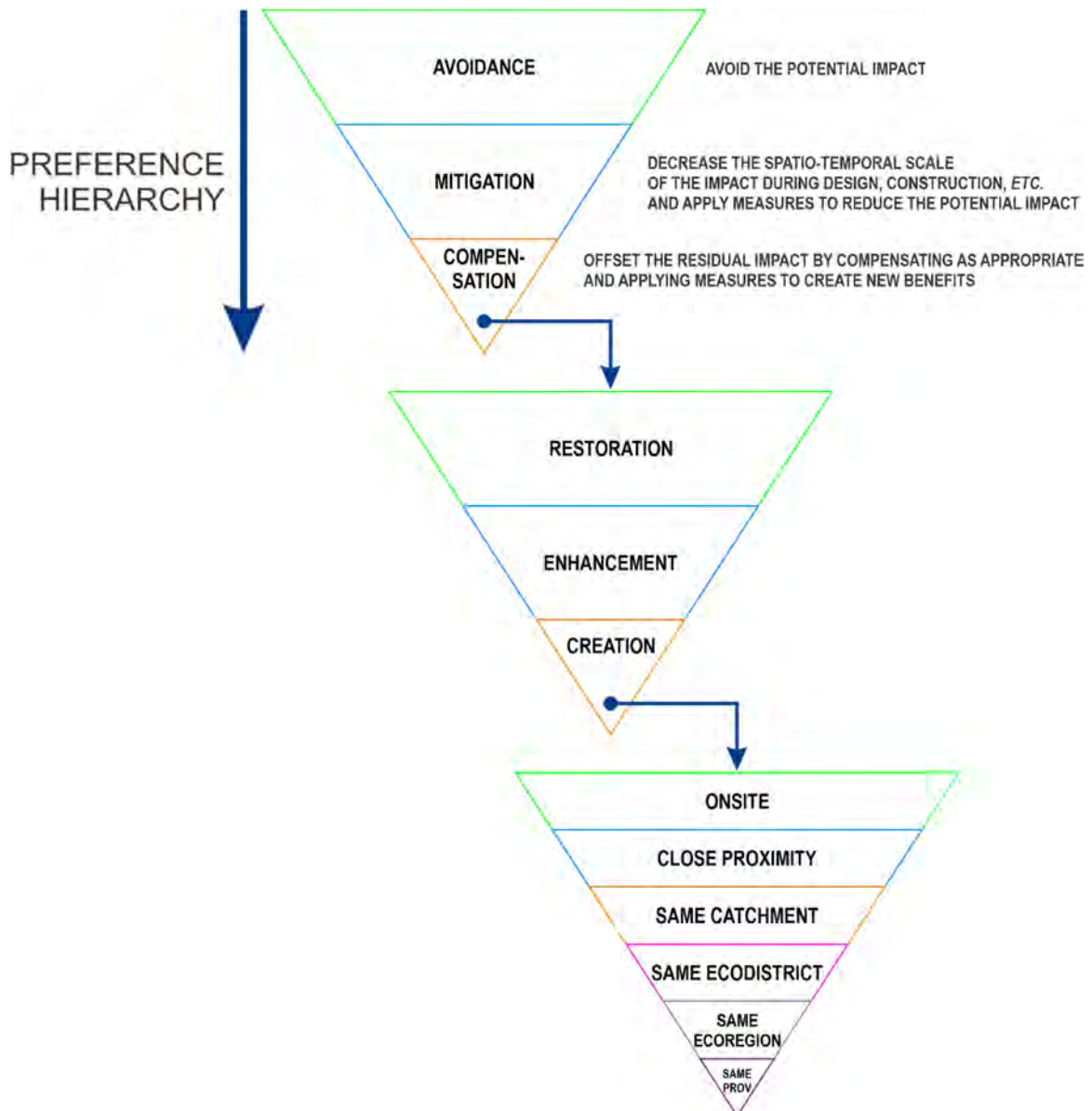

Figure 83. Preference hierarchy associated with impacts under environmental assessment review.

4.3 OVERVIEW OF VALUED ENVIRONMENTAL COMPONENT ANALYSIS

A critical component of the EIA process is identifying and assessing the impact on Valued (socially, economically, culturally and / or scientifically) Environmental Components (VECs). Impacts can be positive or negative. When negative impacts to VECs are identified, it is critical to determine what mitigation measures can be implemented to reduce that impact. In some instances, it may even be necessary to mitigate a positive impact.

Residual effects are also considered in the assessment of potential project environmental impacts. A residual effect is any measurable or demonstrable environmental impact that remains following the implementation of mitigation measures. Each Project activity, component, and associated mitigation measure is assessed on different attributes of the potential for environmental impact (*i.e.*, probability, magnitude, extent, duration, frequency, and reversibility). The potential for residual effects is described for each VEC below. In the instance where a residual effect is expected to occur, the potential impact is further assessed to determine whether any cumulative effects may arise through the interaction between the Project-specific impacts and similar effects from past, present, and / or reasonably foreseeable activities.

4.3.1 *Project Interactions / Scoping*

As noted in Section 2.8, there are five Project stages. Different activities are associated with each stage and not all stages interact with the environment. For this EIA, environmental interactions are strictly limited to the spatial and temporal boundaries of this Project. For example, interactions are not considered in the transportation of wood chips to the Mill as that is already a pre-existing activity; however, the processing of effluent through a new environmental treatment facility 24 hours per day, 7 days a week, and 365 days per year is considered. Similarly, the operation of the lime kiln at the Mill is not considered as it is not part of this Project, but operation of the new water use reduction system is considered.

Decommissioning was not considered part of the impact assessment because the nature of that Project phase is not predictable. Decommissioning is not expected to occur until at least 2070, presumably when the regulatory setting will be somewhat different. Therefore, decommissioning will be assessed just prior to the end of Project operation in order to assess the potential environmental impacts pursuant to the applicable regulatory regime.

A high-level assessment of the Project stages and potential environmental interaction is summarized in Table 38. Accordingly, only Stages II, III, and V require further assessment here as they are the only stages that have potential interactions with the environment that can be identified.

Table 38. Project stages of the proposed environmental treatment facility and water use reduction project at the Reversing Falls Mill in Saint John, New Brunswick. Included are the activities associated with each stage and whether or not there is an interaction with the environment.

Project Stage	Activities	Environmental Interaction
I – Environmental permitting, monitoring, and compliance	<ul style="list-style-type: none"> ➤ Desktop reviews ➤ Non-intrusive field investigations ➤ Permit applications ➤ Site reviews and inspections ➤ Development and review of best management practices 	No
II – Construction	<ul style="list-style-type: none"> ➤ Erecting temporary site facilities for contractors ➤ Excavating and hammering rock ➤ Installing foundations and services ➤ Constructing tanks, pipelines, and buildings ➤ Installing infrastructure ➤ Commissioning infrastructure ➤ Dismantling temporary site facilities for contractors 	Yes
III – Operation and maintenance	<ul style="list-style-type: none"> ➤ Treating effluent ➤ Incinerating and / or composting recovered fibre and solids ➤ Re-stocking and storing chemicals required for treating effluent ➤ Cooling process water 	Yes
IV – Decommissioning	<ul style="list-style-type: none"> ➤ Dismantling, removing, and recycling equipment and infrastructure ➤ Removing contaminated materials ➤ Grading and leveling the site ➤ Reclaiming the site 	Yes, but will be defined at a later date
V – Mishaps, errors, and / or unforeseen events	<ul style="list-style-type: none"> ➤ Potential for spills, contaminant releases, fires, and / or explosions ➤ Operational failures 	Yes

4.3.1.1 VEC Matrix

Collectively, there are three broad VEC categories that are typically reviewed through an EIA process. Based on the activities described in Section 2.0, potential interactions with the environment were identified. Fundy Engineering's Project Team, based on previous environmental impact assessment experience and professional judgment, assessed potential interactions between Stages II, III, and V (*i.e.*, those with an environmental interaction as identified in Table 38) and all of the environmental components described in Section 3.0.

Through this VEC interaction matrix exercise, it was determined that there are 12 environmental components that require detailed assessment with respect to the environmental treatment facility and water use reduction project (*i.e.*, those with a potential Project interaction as noted in Table 39). Those environmental components are identified below as VECs.

Table 39. Assessment of potential interactions of various stages of the proposed environmental treatment facility and water use reduction project at the Reversing Falls Mill

in Saint John, New Brunswick and the environment. Check marks indicate that there is potential for interaction and requires further assessment.

Valued Environmental Component	Project Stage and Environmental Interaction		
	II: Construction	III: Operation and Maintenance	V: Mishaps, Errors and Unforeseen Events
<u>PHYSIO-CHEMICAL ENVIRONMENT</u>			
Climate	NA	NA	NA
Air quality	✓	✓	✓
Sound emissions	✓	✓	✓
Topography	NA	NA	NA
Hydrology	✓	✓	✓
Geology	NA	NA	NA
Hydrogeology	✓	✓	✓
<u>BIOLOGICAL ENVIRONMENT</u>			
Terrestrial flora and fauna	✓	✓	✓
Aquatic flora and fauna	✓	✓	✓
<u>SOCIO-ECONOMIC ENVIRONMENT</u>			
Labour and economy	✓	✓	✓
Archaeological and cultural resources	✓	✓	✓
Land-use	NA	NA	NA
Transportation network	✓	✓	✓
Aesthetics	✓	✓	✓
Protected areas	NA	NA	NA
Recreation and tourism	✓	✓	✓
Health and safety	✓	✓	✓

4.3.2 Impact Assessment Methodology

The impact assessment methodology used for this Project is summarized in Figure 84. Described in the sections that follow are the various steps used in assessing the Project's impact on the environment.

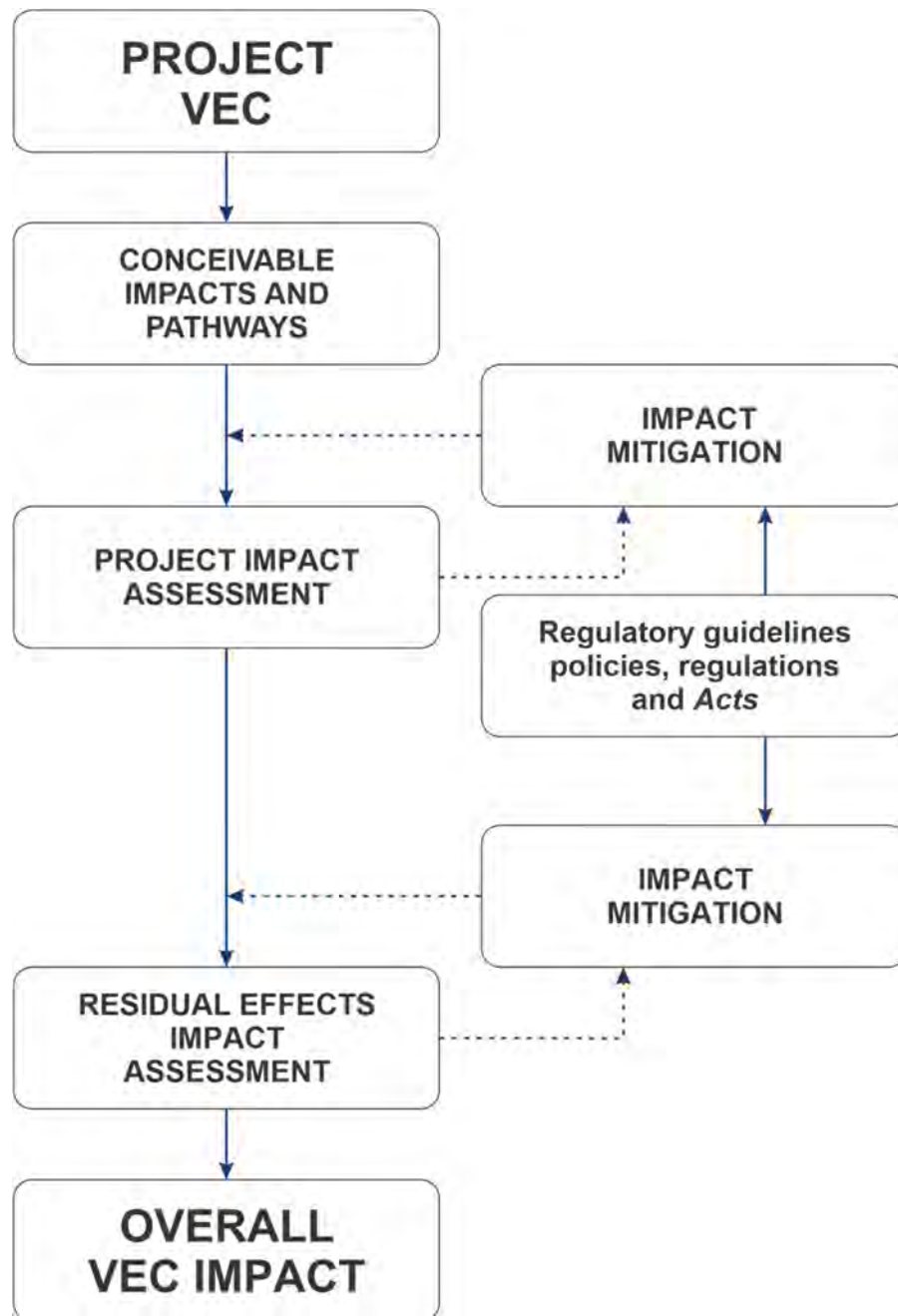

Figure 84. Visual representation of the process used in assessing the Project's impact on the environment.

4.3.2.1 Conceivable Impacts and Pathways

Conceivable impacts and pathways are identified for each VEC, for each of the Project Stages, in order to describe:

- the Project activities that are involved;
- the type of cause-effect relationships that could possibly exist; and
- the mechanisms by which stressors could ultimately lead to effects on the VEC.





Each conceivable impact and pathway represent an area where mitigation measures could be applied to reduce or eliminate a potential effect. It is critical to identify those pathways in order to develop appropriate mitigation strategies.

4.3.2.2 Project Impact Assessment

EIA documents are reviewed by rightsholders, stakeholders, the general public, and industry and regulatory professionals. As such, the methods used to assess the impact of a project on the environment, and vice versa, have to be clear and easy to follow. They must also be robust enough to ensure that all interested parties can understand the conclusions. There are several methodologies used in the EIA process, such as the Leopold Matrix [*Leopold et al.*, 1971], the Battelle Environmental Evaluation System [*Dee et al.*, 1973], and Environmental Risk Assessment [*Wood*, 1995]. None of the methodologies appear to be ideal for all situations [*Goyal and Deshpande*, 2001] and there is no single best set of criteria that can be used to classify all environmental impacts. Generally, there are trade-offs between the amount of effort necessary to acquire and assess the various VECs and the overall results that can be drawn from the various methodologies.

Fundy Engineering employs a visual impact significance symbol summary method for the assessment of VECs, which is analogous to a traffic light (Table 40). The traffic light assessment method has been successfully used by others, such as *Koeller et al.* [2000] and *ODPM* [2002]. Our method, which has proven valuable in many other EIAs, is a way for reviewers to quickly and easily examine the impacts without having to understand a complex environmental assessment process.

Table 40. Fundy Engineering's Valued Environment Component Assessment visual coding method, which is analogous to a traffic light.

Assessment Symbol	Description
	<u>Favourable or little to no impact:</u> criteria receiving this impact level have no significant problems associated with them; they are green lights for the Project.
	<u>Potential impacts that may require some degree of mitigation:</u> criteria receiving this impact level do not appear to have significant problems associated with them; they are yellow lights for the Project and should be approached with caution.
	<u>Not favorable or a major impact:</u> criteria receiving this impact level rating would be difficult to implement; they are red lights for the Project.
	<u>No change in existing impact:</u> criteria receiving this impact level have no additional potential impact from the Project than already currently exists.

Project impact green lights are considered those activities that may yield short-term impacts. Those impacts would be experienced for a brief period of the Project (*i.e.*, a day or week during a Project Stage). For example, a green light may be applied to sound emissions if a pile driver were to be used for a one week period over a year-long construction period where the only loud activity anticipated is the driving of piles. Green lights are also applied to activities that have a positive outcome. Creating long-term employment through the development of a recreational facility, for example, would be a

positive impact that would be assigned a green light in our analysis. If the impact is not entirely positive, then mitigation measures are likely required for green lights.

Project yellow lights are considered to be those activities that extend between the short-term and long-term. Impacts considered long-term are those that may be experienced for a prolonged period of time, such as during the entire duration of the Project. With yellow lights, long-term impacts are not permanent (*i.e.*, they are reversible and as environmental protection methods are improved, the impact may be further reduced). An example of a yellow light would be increased erosion along a linear corridor resulting from the clearing and grubbing of a forest. The impact is reversible (*i.e.*, replanting of vegetation to return to pre-impact conditions) or can be mitigated (*i.e.*, through the implementation of best-management practices, such as silt fences and sedimentation basins). Mitigation measures are required for yellow lights.

Red lights are applied when long-term impacts are considered to be permanent. That is they may cause irreversible change in the environment. An example would be a large and persistent oil spill to a major drinking water aquifer. After halting the spill, considerable effort may be required to remediate the contamination. During remediation, which would likely be prolonged, a new source of drinking water would be required. Red lights require that mitigation measures be developed.

When there is no anticipated change to the component as a result of the project, a blue light is applied. Blue lights do not require mitigation because there is no change.

4.3.2.2.1 Impact Assessment Scoring Matrices

Fundy Engineering's traffic-light assessment method of Table 40 summarizes a more rigorous process; impact assessment scoring matrices were completed for each VEC in order to produce the traffic light summaries. Those matrices, which were completed via expert opinion, are provided in Appendix IX. The detailed matrices characterize the impacts of each VEC sub-component for the three Project Stages where interactions are expected (*i.e.*, Table 38 and Table 39). The impact characterization used in the impact assessment scoring matrices is summarized in Table 41.

Numerical values were used to represent the importance assigned to each impact category within the matrices; the higher the number, the more important the impact and vice versa. The impact categories, the ranks, and the assigned importance scores are summarized in Table 42. As summarized in Table 43, the sum of the importance scores was used to determine the overall score for the impact and in turn the impact significance.







Table 41. Environmental impact characterization used in the assessment of the Valued Environmental Components and their sub-components.

Impact Category	Rank	Description
Direction	Positive	Improvement over baseline conditions
	Neutral	No change from baseline conditions
	Negative	Deterioration from baseline conditions
Probability	Low	Previous research, knowledge, experience, and / or traditional knowledge indicates that there is a small likelihood that the environmental component has experienced the same impact from activities of similar project types; < 25 % chance of occurring
	Moderate	Previous research, knowledge, experience, and / or traditional knowledge indicates that the environmental sub-component may have experienced the same impact from activities of similar project types; 25 % to 75 % chance of occurring
	High	Previous research, knowledge, experience, and / or traditional knowledge indicates that the environmental sub-component has experienced the same impact from activities of similar project types; > 75 % chance of occurring
Magnitude	Low	Imperceptible change from baseline conditions
	Moderate	Observable increase over baseline conditions, but not substantial
	High	Substantially above baseline conditions
Extent	Local	Confined to the Project boundaries
	Regional	Extending beyond the Project boundaries, but confined to the Saint John region
	Provincial	Extending beyond the Saint John region
Duration	Short-term	< 25 % of the time during the Project phase
	Medium-term	25 % to 75 % of the time during the Project phase
	Long-term	> 75 % of the time during the Project phase
Frequency	Temporary	Occurs for a limited period during the Project phase
	Intermittent / irregular	Occurs more than once, but does not occur all the time during the Project phase
	Permanent / continuous	Occurs throughout the entire Project phase
Reversibility	Reversible	Impacts that are not permanent and can be changed back to the original condition
	Irreversible	Impacts that are permanent and there is no chance to change back to the original condition

Table 42. Impact categories, ranks, and assigned importance scores used in the assessment of significant environmental impacts.

Importance Score	Impact Category and Rank					
	Probability	Magnitude	Extent	Duration	Frequency	Reversibility
0	Not applicable / negligible					
1	Low	Low	Local	Short-term	Temporary	Reversible
2	Moderate	Moderate	Regional	Medium-term	Intermittent / irregular	
3	High	High	National	Long-term	Permanent / continuous	Irreversible

Table 43. Assessment scores, impact significance, and symbols used in the assessment of significant environmental impacts.

Overall Score	Impact Significance	Symbol
<i>Negative Impacts</i>		
≤ 8	Favourable or little to no impact	
9 to 14	Potential impacts that may require some degree of mitigation	
≥ 15	Not favorable or a major impact	
<i>Positive Impacts</i>		
≥ 11	Favourable or little to no impact	
7 to 10	Potential impacts that may require some degree of mitigation	
≤ 6	Not favorable or a major impact	

4.3.2.3 Impact Mitigation

The identification and development of mitigation measures was an iterative process undertaken during the VEC impact assessment and the residual and cumulative impact assessment. Regulatory guidelines, policies, regulations, and Acts applicable to the protection of the VEC were considered in the development of the mitigation measures. Development of impact mitigation was critical to reducing the overall impact of the Project on the environment. Ranking within the impact assessment scoring matrices considered the implementation of the mitigation measures identified.

It is expected that the mitigation measures identified will become part of the Project-specific EPP. Roman numerals in curly brackets follow each of the listed mitigation measures and refer to the applicable Project Stage(s).

4.3.2.4 Residual Impact Assessment

Residual impacts were considered in the assessment of potential project environmental impacts. A residual impact is one where any measurable or demonstrable environmental impact remains following the implementation of mitigation measures. Each Project activity, component, and associated mitigation measure was assessed on different attributes of the potential for environmental impact. The potential for residual effects is described for each VEC below.

4.4 POTENTIAL PROJECT IMPACTS ON THE ENVIRONMENT

4.4.1 Valued Environmental Components Assessed

The following VECs were assessed for the environmental treatment facility and water use reduction project at the Reversing Falls Mill in Saint John, New Brunswick:

- physio-chemical environment:
 - air quality;
 - sound emissions;
 - surface water quantity and quality; and
 - groundwater quantity and quality;
- biological environment:
 - terrestrial flora and fauna;
 - aquatic flora and fauna; and
- socio-economic environment:
 - labour and economy;
 - archaeological and cultural resources;
 - transportation network;
 - aesthetics;
 - recreation and tourism; and
 - health and safety.

The identified VECs were assessed with consideration given to risks associated with construction (*i.e.*, Stage II), operation and maintenance (*i.e.*, Stage III), and any mishaps, errors, and / or unforeseen events (*i.e.*, malfunctions or accidents) that may occur as a result of the proposed Project (*i.e.*, Stage V). The assessment of the VECs listed above is described in detail in the sections that follow.

4.4.2 Physio-Chemical Environment

4.4.2.1 Air Quality

As Canadians, we have very good air quality compared to other industrialized nations, and this is especially true in New Brunswick. Air quality is an important VEC to consider as emissions from large industrial projects can have both localized effects (*e.g.*, from odours, particulate matter, Volatile Organic Compounds (VOCs), *etc.*) as well as global effects (*i.e.*, emission of greenhouse gases).

Canada is a signatory to various international agreements, conventions, and protocols. Some, including *The Paris Agreement* of the United Nations Framework Convention on Climate Change, involve commitments requiring action relating to climate change and GHG emissions [UNFCCC, 2021]. *The Paris Agreement* affects all Canadian Provinces and Territories. In December 2016, the federal government released the *Pan-Canadian Framework on Clean Growth and Climate Change*. *The Paris Agreement* goal is to limit global warming to well below 2 °C, preferably 1.5 °C, compared to pre-industrial levels.

In 2016, the Province of New Brunswick issued *Transitioning to a Low-Carbon Economy* action plan, which represents the provincial Climate Change Action Plan [PNB, 2016]. The goal of the action plan is to reduce emissions and build resilience by adapting to a changing climate. As such, the action plan focuses on seven key areas:

- provincial government leadership;
- collaboration with First Nations;
- GHG emission reductions;
- adaptation to the impacts of climate change;
- economic opportunities;
- accountability and reporting; and
- funding for climate change.

All projects constructed in New Brunswick must adhere to the Province's air emission guideline and climate change action plan.

4.4.2.1.1 Conceivable Impacts and Pathways

There are several sources of air emissions associated with the Project. Air emissions will be both intermittent (e.g., heavy equipment used during construction, back-up emergency diesel generators used during power outages, etc.) and continuous (i.e., generated electricity purchased from NB Power).

Activities and physical works that may occur during the Project and their associated potential impacts are summarized in Table 44. In the section that follows, the potential impacts are assessed in concert with the development of mitigation measures.

Table 44. The type of cause-effect relationships that are possible and the mechanisms by which stressors could ultimately lead to impacts on air quality during various activities associated with the proposed environmental treatment facility and water use reduction project at the Reversing Falls Mill in Saint John, New Brunswick.

Activity	Conceivable Impacts and Pathways
Construction and operational traffic	➤ An increase in personal, construction, and delivery vehicles could impact the local air quality
Vegetation clearing, grubbing, stripping, grading, and landscaping	<ul style="list-style-type: none"> ➤ Fugitive dusts could be created when tree clearing and topsoil removal is occurring or when materials are stockpiled ➤ Planting vegetation can increase the air quality of the Project site
Operation and maintenance of heavy equipment	<ul style="list-style-type: none"> ➤ Construction equipment is a major source of combustion emissions which will potentially have an effect on the local microclimate and local and regional air quality ➤ Fugitive dusts will be created when construction equipment travel over unpaved

Activity	Conceivable Impacts and Pathways
	roadways
Rock excavating with pneumatic hammers	<ul style="list-style-type: none"> ➤ Pneumatic rock breaking activities can affect local air quality, primarily with respect to dust generation
Treatment of effluent	<ul style="list-style-type: none"> ➤ Generation of electricity can generate GHG emissions ➤ Establishment of conditions suitable for the formation of bacteria ➤ Heating of ambient air during the cooling process

There is always a potential for mishaps, errors, and / or unforeseen events to occur regardless of how stringent the implemented mitigation measures are. The primary emitter under such a scenario for the air quality VEC would be operation of back-up diesel generators. If such an event were to occur, then it is likely that it would be of short duration (hours) while the problem is resolved.

Air quality was selected as a VEC because it has the potential to be affected during all aspects of the Project (e.g., construction and commissioning, operation and maintenance, and mishaps, errors, and / or unforeseen events). The following potential impacts associated with air quality were assessed:

- micro-climate (*i.e.*, temperature and precipitation) of the local area;
- emissions of CO;
- emissions of NO_x;
- emissions of SO₂;
- emissions of VOCs;
- emissions of PM (*i.e.*, from exhausts and dusts); and
- airborne bacteria.

4.4.2.1.2 Potential Impacts

The complete assessment of potential impacts of the potential Project on air quality is provided in Table 49. Overall, the assessment yielded two green lights, 16 yellow lights, and three no change lights.

It is important to note that since 2010, Total Reduced Sulfur (TRS) from IPP's air quality monitoring station (*i.e.*, Milford Road Air Quality Monitoring Station) adjacent to the Project footprint in the vicinity of the MBBRs (Figure 85) has been published annually by the NBDELG. That station may have to be moved to facilitate Project construction and subsequent operation. If it requires moving (*n.b.*, this will be determined during detailed engineering), it will be done in consultation with representatives with the NBDELG's Air and Water Sciences Branch.

Emissions by heavy equipment will be the greatest during site preparations and construction. For example, the majority of construction equipment used will likely have diesel or gasoline combustion engines, which will increase atmospheric emissions (*i.e.*, CO, NO_x, SO₂, VOCs, and PM). It is anticipated that heavy equipment used during Project construction and vehicle use related to workers travelling to and from the site will produce about 6 900 tonnes of GHG emissions (*i.e.*, CO_{2eq}) during Stage II (*i.e.*, ~ 27 months). Project-related GHG emission estimates are provided in Appendix X.



Figure 85. Location of the total reduced sulphur air quality monitoring station at the Reversing Falls Mill in Saint John, New Brunswick in relation to the proposed environmental treatment facility.

The micro-climate is expected to be minimally affected during Stage III (Table 49). When in operation, the indirect air coolers will exhaust warm air that is sometimes humid. This may result in air temperatures and sometimes humidity levels to be higher in a zone around the indirect air coolers. The zone of impact is expected to be small as the volume of air going through the systems is comparatively small compared to the local airshed.

It is estimated that the Mill will require an additional 4 MW of electricity to operate the Project. It is anticipated that the electricity will be purchased from NB Power, which has a mixture of electricity generation sources, including about 30 % from fossil fuels. During operations (*i.e.*, Stage III), there will also be emissions associated with travel for the five operators and the solids / fibre trucking to the compost facility. It is estimated that annual Project operation emissions will be about 450 tonnes of CO_{2eq}.

There may be an opportunity to co-combust recovered fibre and / or dewatered solids from the ETF with hog fuel (*i.e.*, wood byproduct or waste that can be burned for fuel) within the Mill's power boiler. That would reduce CO_{2eq} emissions by displacing the burning of other fuels within NB Power's facilities. Regardless, combustion emissions will be generated during Project operation and maintenance, which is the reason yellow lights were applied to the majority of impacts during that Stage (Table 49).

The probability that the Project will disperse bacteria into the airshed when exhausting air through the indirect air coolers is negligible. As detailed in Section 2.7.1.4.3, the indirect air coolers are being custom designed to include fin coolers that allow any additional water

droplets contained in the air stream to condense and fall out before reaching the exhaust fans. Furthermore, an oxidant injected into the spray water will inhibit bacterial growth.

Should a mishap, error, and / or unforeseen event occur, there is a potential that impacts could be realized to air quality. Therefore, yellow lights were applied to most potential impacts during that Stage (Table 49).

Overall, the potential impacts identified for air quality related to this Project can be reduced or eliminated using the mitigation measures described below.

4.4.2.1.3 Proposed Mitigation

At a minimum, the mitigation measures outlined below should be undertaken by Project personnel to ensure that potential impacts to air quality are minimized.

- A Project-specific environmental protection plan will be developed to provide best-management practices that all Project personnel should follow in order to limit the potential for impacts to air quality to occur. {Applicable to Stages II, III, and V}
- All Project personnel should be briefed on the potential impacts that equipment emissions can have on the quality of the local airshed and briefing information should range from describing emissions that are released from equipment during operation to how those emissions can be reduced. {II, III, and V}
- Mitigation measures developed and included in the Project-specific environmental protection plan should be adhered to in order to adequately address potential impacts. {II, III, and V}
- Construction, operation, and maintenance equipment should only be operated at optimum loading rates. {II and III}
- Heavy equipment should be turned off when not in use and / or when practical (*i.e.*, anti-idling policy). {II and III}
- The number of vehicle kilometers travelled should be kept to a minimum (*i.e.*, there should be no unnecessary operation of equipment in and around the site). {II and III}
- Heavy equipment should be operated using clean fuels (*i.e.*, ultra-low sulphur diesels), where available and practical. {II and III}
- Heavy equipment exhaust emission systems should meet the recommended standards. {II and III}
- Equipment should be maintained according to manufacturer recommended servicing periods. {II and III}
- Heavy equipment should be refueled using a protocol designed to mitigate environmental risks. {II and III}
- No solid waste should be burned onsite. {II and III}
- Construction, operation, and maintenance vehicles should comply with the posted / recommended speed limits and, as appropriate, reduce speed when travelling on surfaces where dusts are generated (*i.e.*, gravel or dirt roadways). {II and III}
- If the application of water as a dust suppressant is deemed necessary on local gravel roadways (*n.b.*, this is the preferred method of dust suppression), it should be applied using suitable equipment (*e.g.*, a tanker truck equipped with spray bars

- and methods of controlling water flow, etc.). {II and III}
- Material stock piles (e.g., soil, sand, aggregate, etc.) and spoils piles should be sited in locations that minimize the impact from prevailing winds. {II and III}
 - Allowing vegetation to re-establish itself should reduce impacts to air quality, especially those associated with fugitive dusts generated from wind blowing over bare soils. {II and III}
 - The indirect air coolers, which are an indirect cooling technology, should be operated as per the manufacturer's recommendations to ensure they operate efficiently. {III}
 - Planting vegetation or allowing vegetation, including grasses, shrubs, and trees, to regenerate / grow, can moderate the micro-climate changes at the Project site. This could include planting additional trees and bushes along the landscaped berm. {III}
 - If possible, recovered fibre and / or dewatered solids should be incinerated in the onsite power boiler to generate electricity and offset that required for purchase from NB Power. {III}
 - The indirect air coolers should be registered with the City of Saint John when applying for the Project's building permit. {III and V}
 - The plume abatement systems of the indirect air coolers should be in operation and, where possible, the indirect air coolers should be operated in dry mode during winter months. {III and V}
 - ASHRAE Standard 188-2018 should be followed. {III and V}
 - Regular monitoring of microorganisms should be undertaken when the indirect air coolers are operational. {III and V}
 - Emergency response and contingency plans should be designed to prevent any major and / or sustained environmental damage during any errors, mishaps, and / or unforeseen events. {III and V}
 - A contingency response plan should be developed to monitor, control, and eliminate bacteria growth. {V}

4.4.2.1.4 Potential Post-Mitigation Residual Impacts

Overall, this Project is expected to result in moderate impacts to local air quality as summarized in Table 49. There are no residual impacts anticipated to air quality as a result of this Project.

The Mill currently operates under an ATO as per the Air Quality Regulation [97-133] of the New Brunswick *Clean Air Act* [S.N.B. 1997, c C-5.2] (i.e., ATO I-9509). That approval process will remain in place once the Project is in operation and may be modified to include any emissions related to the Project.

4.4.2.2 Sound Emissions

Although the Mill is located in a traditional heavy industrial area of west Saint John, some residential properties do exist in the area (Refer to Section 3.3.5). Sound will be emitted by most construction equipment and some of the Project equipment (Figure 86). Those sounds may be above ambient sound levels. If they become too high, those sound levels may be an annoyance or health concern to nearby residents and may cause a disturbance

to local wildlife. Additionally, sound levels could be a hazard to all Project personnel if appropriate precautions are not taken. Because of this, sound was selected as a VEC.

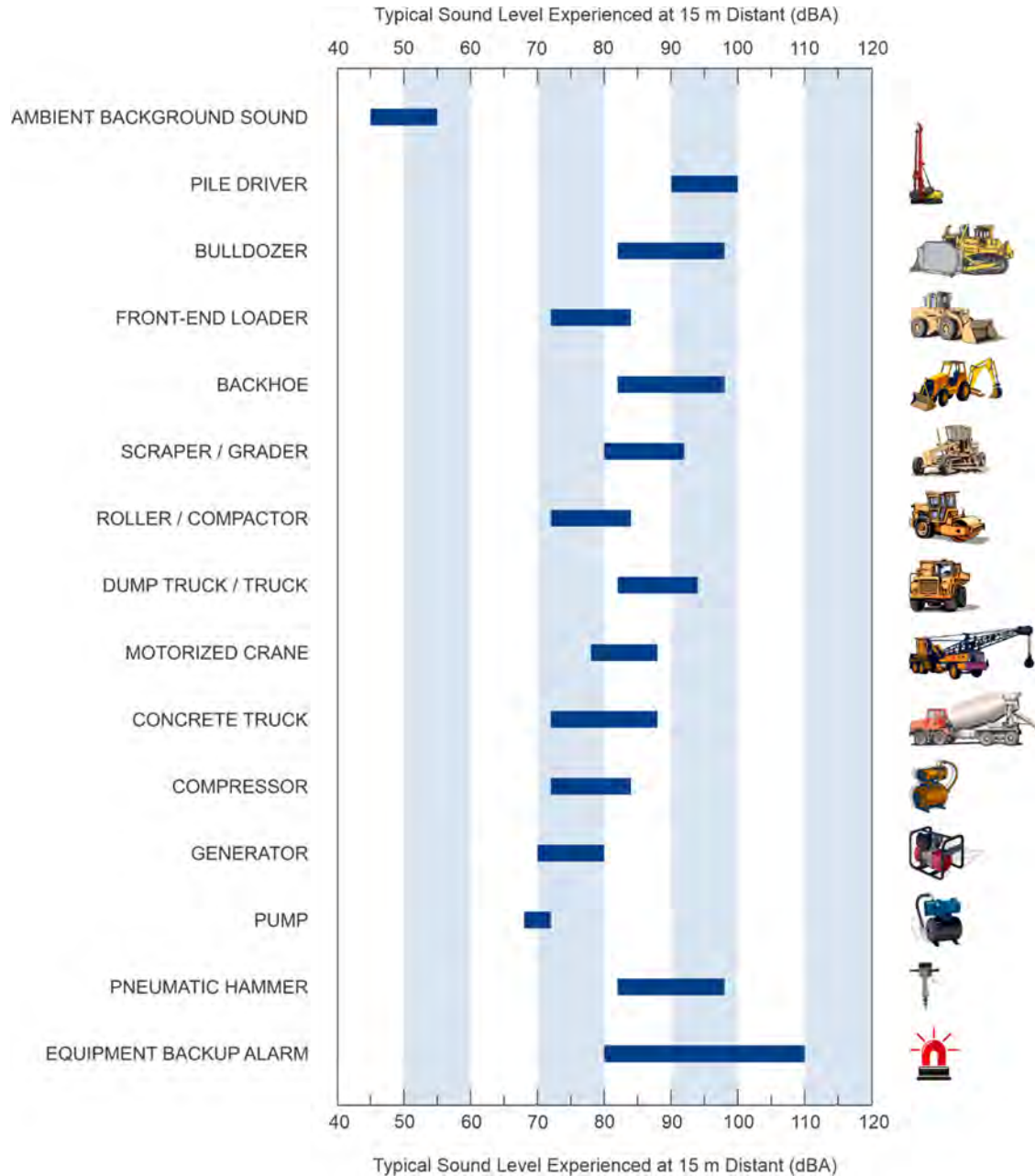

Figure 86. Typical sound levels from construction equipment experienced by a receptor at 15 m distant. After USEPA [1971].

Construction process equipment and activities that produce sound waves will also generate ground vibration. Therefore, ground vibrations are assessed within the sound VEC. When vibration levels exceed the thresholds of human perception, they often become an annoyance. Construction activities, such as pile driving, the dynamic compaction of loose soils, rock breaking, and the operation of heavy construction equipment induce ground and structure vibrations. During operation, the pumps, fans, and air blowers will be the main source of potential vibration at the site.

Loud sounds are generally associated with construction activities and industrial operations. Sounds and vibrations during construction and operation will be emitted by both mobile sources (*e.g.*, heavy equipment, rock hammering, *etc.*) and stationary sources (*e.g.*, generators, pumps, fans, blowers, *etc.*). The intensity and frequency of those emitted sounds will vary. Sound pressure levels, which are measured in decibels, describe intensity. Every 10 dB increase in sound pressure level corresponds to a tenfold increase in intensity, which is perceived by humans as being twice as loud [*Health Canada*, 1998]. Typically, sounds with a frequency / pitch in the range of 20 Hz to 20 000 Hz are heard by people and the maximum sensitivity to sound occurs in the 1 000 Hz to 3 000 Hz range. Therefore, sounds with very low or very high frequencies seem less disturbing to humans than those in the middle frequencies, even at equal intensities.

4.4.2.2.1 Conceivable Impacts and Pathways

Activities and physical works that may occur during the Project that may cause sounds and vibrations are listed in Table 45. The potential impacts on the sound environment and their associated pathways are also included for reference. In the section that follows, the potential impacts are assessed in concert with the development of mitigation measures.

Table 45. The type of cause-effect relationships that are possible and the mechanisms by which stressors could ultimately lead to impacts on the sound environment during various activities associated with the proposed environmental treatment facility and water use reduction project at the Reversing Falls Mill in Saint John, New Brunswick.

Activity	Conceivable Impacts and Pathways
Construction traffic	<ul style="list-style-type: none"> ➤ Vehicles and equipment travelling across road surfaces emit sounds, which may be heard at nearby residences ➤ Vehicles and equipment travelling across road surfaces may cause ground vibrations that could extend to nearby residences
Vegetation clearing, grubbing, stripping, grading, and landscaping	<ul style="list-style-type: none"> ➤ Loss of vegetation may affect the attenuation of sound from the Project site (<i>i.e.</i>, reduction in sound absorption) ➤ Loss of ground cover may affect sounds emitted from the Project site (<i>i.e.</i>, reduction in ground friction and the replacement of soft surfaces for hard surfaces)
Operation and maintenance of heavy equipment	<ul style="list-style-type: none"> ➤ Worker exposure to loud sounds and / or continuous sounds can affect hearing temporarily and / or permanently ➤ Worker exposure to sounds can cause fatigue ➤ Worker exposure to sounds can cause annoyance and stress ➤ Sound emissions can affect the sleep quality of nearby residents (<i>e.g.</i>, affect them falling asleep, awakening them during sleep, <i>etc.</i>) ➤ Loud sounds (<i>e.g.</i>, back-up alarms) and / or continuous sounds (<i>e.g.</i>, traffic) can be an annoyance to nearby residents, which could become stressful ➤ Loud sounds may be reflected off the waters of the Saint John River and travel greater distances than they would across land
Pneumatic rock breaking activities and pile driving	<ul style="list-style-type: none"> ➤ Worker exposure can cause fatigue ➤ High-energy impulsive sounds (<i>i.e.</i>, breaking) coupled with ground vibrations can be an annoyance to nearby residents, which can cause stress ➤ Highly impulsive sounds (<i>e.g.</i>, pneumatic hammering and pile driving) coupled with ground vibrations can be an annoyance to nearby residents, which can cause stress ➤ Vibrations may propagate outwards from the Project site

Activity	Conceivable Impacts and Pathways
Development of rock faces	➤ Excavation of rock during site preparation will create large rock faces, which may act as barriers to sound emitted from the Project site
Landscaping	➤ Planting vegetation and development of berms can help attenuate sounds emitted from the Project site

There is always a potential for mishaps, errors, and / or unforeseen events to occur regardless of how stringent the implemented mitigation measures are.

The following specific potential impacts were assessed for the Project:

- sound pressure levels (*i.e.*, intensity);
- sound duration;
- sound repetition; and
- ground vibration.

4.4.2.2.2 Potential Impacts

Table 50 is the complete assessment of potential impacts conducted for sound emissions associated with the Project. Of the 12 potential impacts, four were assigned yellow lights. Sound emission levels, sound duration, sound repetition, and ground vibrations during Stage II yielded yellow lights.

During operation of the Project, there is expected to be no change in operational sound emissions emitted and / or ground vibrations emanating from the Mill site. All loud equipment (*i.e.*, pumps and blowers) will be contained in enclosures that will dampen sound emissions. Any exposed equipment is expected to emit sounds < 80 dBA. For these reasons, no change lights were applied to all potential impacts during Stage III (Table 50).

Equipment brought to the site to deal with any mishaps, errors, and / or unforeseen events may not have appropriate noise dampening measures or vibration reduction devices in place. Their operation would be expected to be of short duration and only long enough to rectify the situation. Green lights were applied to all potential impacts during Stage IV (Table 50).

4.4.2.2.3 Proposed Mitigation

For this Project, the mitigation of environmental sounds is best achieved through the use of sound source controls and sound receptor controls. The following mitigation measures will be implemented by Project personnel as source controls to minimize the potential impact of sound emissions to nearby receptors (*i.e.*, residents and the general public), particularly during Phases II and IV.

- Project personnel should ensure that all equipment is equipped with the appropriate manufacturer designed sound level abatement equipment (*i.e.*, mufflers and shrouds). {Applicable to Stages II and V}
- The exhaust systems of all Project equipment should be inspected regularly (*i.e.*, daily or weekly) to ensure that sound level abatement equipment is operating

- properly. {II and V}
- Equipment should be maintained according to manufacturer's recommended servicing periods. {II and V}
 - The idling of all heavy equipment should be kept to a minimum and excessive engine throttling should be avoided. {II and V}
 - Engineered controls should be implemented to reduce sound levels emitted from equipment (*i.e.*, shrouds and barriers) and at the source to reduce vibrations that can be transferred to the ground surface and propagate outwards (*i.e.*, cushions and dampening pads). {II}
 - Loud construction activity (*e.g.*, pile driving and rock breaking, *etc.*) should be scheduled / planned to occur during normal workday / daylight hours (*i.e.*, 7 AM through 7 PM Monday through Saturday), where possible, to limit any potential annoyance to residential receptors. Loud activities should be scheduled to occur concurrently and all loud activity should conform to the City of Saint John's By-Law Respecting the Prevention of Excessive Noise in the City of Saint John [M-22]. {II}
 - The pile driver should be equipped with the appropriate manufacturer designed sound emission abatement equipment and, where practical, shrouds should be used to help minimize sounds emitted from pile driving activity. {II}
 - Where possible, hydraulic impact pile drivers should be used instead of conventional diesel drop hammers in order to reduce sounds emitted from pile driving activity. {II}

The following mitigation measures will be implemented by Project personnel as sound receptor controls.

- Nearby residents and businesses should be notified one week prior to the start of pile driving activities. {II}
- A protocol should be developed for receiving, investigating, managing, and tracking residential complaints in a timely manner regarding sound and vibrations emitted from the Project site. {II}

The general mitigation measures provided below will also be implemented for the Project.

- A Project-specific environmental protection plan will be developed to provide best-management practices that all Project personnel should follow in order to limit the potential for impacts to the sound environment to occur. {II and V}
- All Project personnel should be briefed on the potential impacts the Project may have on sound and sound levels; this could range from explaining that daily inspections and regular maintenance should be done on all heavy equipment to ensure they running as designed and are not unnecessarily contributing to construction noise. {II and V}
- Mitigation measures developed and included in the Project-specific environmental protection plan should be adhered to in order to adequately address potential impacts. {II and V}
- In the event of an emergency, equipment with proper sound abatement technologies may not be readily available. What will be more important at this stage is correcting the error, mishap, and / or unforeseen event to limit any and all permanent environmental impact(s). {II and V}

4.4.2.2.4 Potential Post-Mitigation Residual Impacts

Project construction may result in some short-term sounds greater than are currently emitted from the Mill site. These potential impacts can be mitigated as noted above. During operation, it is anticipated that there will be no change in sound emissions.

The Project design includes a landscaped berm between the ETF and properties along Milford Road as described in Section 2.7.1.9. If there is public concern regarding the possibility of additional sounds being emitted from the Project, additional vegetation could be planted within the landscaped berm. In addition to serving as a visual barrier, the berm will serve as a sound barrier between the ETF and nearby residential properties.

4.4.2.3 Surface Water Quality and Quantity

The Saint John River Watershed is a rich and important ecosystem biologically, socially, economically, and culturally. A perennial connection has existed between humans and the Saint John River. The River provides habitat for numerous species and is a source of water for many purposes, such as drinking water and irrigation. The River is also used for navigation, recreation, energy production, and industrial purposes.

The majority of New Brunswick's population growth has occurred adjacent to the Saint John River. As industries developed, so too did the residential population required to support them. The Mill sits on the Saint John River bank at the confluence with Saint John Harbour on the Bay of Fundy near the centre of Saint John.

Studies in the 1960s revealed that water quality along specific stretches of the Saint John River was poor [CRI, 2011]. As a result of those findings, significant improvements to water quality of the River were made between 1972 and 1984 when municipalities and industries installed systems for treating effluent prior to discharge. Since then, there has been continuous water quality improvements as treatment systems are upgraded and flows are reduced.

4.4.2.3.1 Conceivable Impacts and Pathways

Project activities and physical works that may cause surface water quality and quantity impacts are listed in Table 46. The potential impacts on the surface water environment and their associated pathways are also included for reference. In the section that follows, the potential impacts are assessed in concert with the development of mitigation measures.

Table 46. The type of cause-effect relationships that are possible and the mechanisms by which stressors could ultimately lead to impacts on the surface water environment during various activities associated with the proposed environmental treatment facility and water use reduction project at the Reversing Falls Mill in Saint John, New Brunswick.

Activity	Conceivable Impacts and Pathways
Vegetation clearing, grubbing, stripping, grading, and landscaping	<ul style="list-style-type: none"> ➤ Increased erosion potential whereby exposed sediments may be entrained in overland flow and subsequently transported to the Saint John River ➤ Altered overland flow conditions (<i>i.e.</i>, timing, duration, and frequency) due to changes in slope, removal of vegetation, ditching, <i>etc.</i> may cause water to be quickly transported to the River resulting in flashy conditions

Activity	Conceivable Impacts and Pathways
	<ul style="list-style-type: none"> ➤ Runoff from stockpiled spoils may contain increased sediment loads that are subsequently transported to the Saint John River ➤ Loss of vegetation may result in a change in the nutrients and chemical species being introduced to the River
Rock breaking and excavating with pneumatic hammers	<ul style="list-style-type: none"> ➤ Creation and exposure of large rock faces at the edge of excavations may be new sources of groundwater discharge (<i>i.e.</i>, seepage faces) that generate more surface water runoff that has to be managed ➤ Runoff from stockpiled shot rock and excavated rock may contain increased sediment loads that are subsequently transported to the River
Operation and maintenance of heavy equipment	<ul style="list-style-type: none"> ➤ Ground spills of hydrocarbons during refueling operations (<i>i.e.</i>, gasoline and diesel) may be washed in to the Saint John River ➤ Leaks of hydraulic fluids, oils, <i>etc.</i> during normal operations may spill on to the ground and be washed in to the River
Temporary construction personnel sanitary facilities	<ul style="list-style-type: none"> ➤ Leaks or spills on the ground during use or maintenance may cause untreated sanitary waste to be introduced to the Saint John River
Storage and handling of various hazardous chemicals	<ul style="list-style-type: none"> ➤ Leaks or spills on the ground during the handling and storage of hazardous chemicals (<i>e.g.</i>, paint, epoxies, concrete additives, cleaners, solvents, <i>etc.</i>) may be washed in to the River
Foundation construction and roadway paving	<ul style="list-style-type: none"> ➤ Dewatering activities may cause sediment to be entrained in discharged water that could be subsequently transported to the Saint John River ➤ Foundations and asphalt roadways / parking areas are impermeable surfaces, which may change in quantity of water directed to the aquifer and increase the amount directed to the Saint John River
Dust suppression and winter roadway clearing	<ul style="list-style-type: none"> ➤ If chemical dust suppressants are used on roadways, they may be entrained in overland flow and subsequently transported to the Saint John River ➤ If salt is used for winter roadway maintenance, it may be entrained in overland flow and subsequently transported to the River
Temporary storage of construction and hazardous waste	<ul style="list-style-type: none"> ➤ Precipitation may come in contact with construction and hazardous waste that is temporarily stored onsite prior to safe disposal, which may cause water to become contaminated and subsequently be introduced to the Saint John River
Warm water discharge	<ul style="list-style-type: none"> ➤ Thermally different discharges from ambient conditions could alter the thermal regime of the Saint John River at Mill Cove
Treated effluent discharge	<ul style="list-style-type: none"> ➤ Chemically different discharges from ambient conditions could alter the chemical composition of the Saint John River at Mill Cove

Because various Project activities have the potential to impact the surface water environment, it was identified as a VEC that required assessment. Based on the conceivable impacts and pathways identified in Table 46, the following specific potential impacts were assessed:

- surface water physical quality (*i.e.*, turbidity, suspended sediment, and temperature);
- surface water biological quality (*i.e.*, microbiology);
- surface water chemical quality (*i.e.*, general chemistry and trace metals);
- surface water quantity (*i.e.*, runoff volume, drainage patterns, and discharges); and
- contamination by hydrocarbons / hazardous chemicals.

4.4.2.3.2 Potential Impacts

During construction, there is an increased potential for impacts to the surface water environment. That is why yellow lights were applied to three of the five potential impacts during that Project Stage (Table 51); however, BMPs outlined in the Project-specific EPP document should mitigate those impacts.

The Project is being constructed to improve the quality of the treated effluent discharged to the Saint John River. The Mill's effluent will continue to comply with the limits outlined in the Water Quality ATO. As a result, the ETF was assessed as a positive environmental impact during operation and maintenance.

Once the ETF is in operation, BOD₅, TSS, and COD_{TOTAL} are predicted to decrease from existing conditions (*i.e.*, refer to Table 8):

- BOD₅ daily maximum:
 - existing: 10.6 kg · t⁻¹; and
 - after Project: 2.0 kg · t⁻¹;
- TSS daily maximum:
 - existing: 10 kg · t⁻¹; and
 - after Project: 1.5 kg · t⁻¹; and
- COD_{TOTAL} daily maximum:
 - existing: 39.7 kg · t⁻¹; and
 - after Project: 22.3 kg · t⁻¹;

The above are marked favourable improvements, which should enhance the physical quality of the surface water at the MMO.

A temperature monitoring program was completed in July and August 2020 within Mill Cove where the cooling water intake will be located. Data were collected at 3 m intervals at low tide, mid tide, 2.5 hours before high tide, and at high tide. Results (*i.e.*, refer to Appendix XI) suggest waters of Mill Cove to be extremely well-mixed (*i.e.*, there was no thermal stratification present), which is likely related to its location immediately downstream of Reversing Falls. Large discharge volumes from the River combined with the strong diurnal tides produce the robust mixing within Mill Cove. Based on this information, it is not believed that the discharge of warmed brackish water will have any impact on the thermal regime of the Saint John River within Mill Cove.

Results for the complete mixing of the two volumes of water (*i.e.*, Saint John River with the warm water discharge), for summer and winter conditions are provided in Table 47 below. It is estimated that this cooling process will yield insignificant changes (*i.e.*, 0.03°C) to the thermal regime of the Saint John River at Mill Cove; however, there will be an overall reduction in warm water discharged to the Saint John River because of the overall reduced effluent flow.

Table 47. Estimated summer and winter mixed temperature of the Saint John River at the point of the warm water discharge from the Reversing Falls Mill in Saint John, New Brunswick.

Parameter	Summer*		Winter*	
	Saint John River	Warm Water Discharge	Saint John River	Warm Water Discharge
Flow (m ³ · min ⁻¹) [†]	59 400	95	59 400	95
Volume (m ³)	59 305	95	59 305	95
Temperature (°C)	18	35	4	25
Density (kg · m ⁻³) [‡]	998.595	994.029	998.595	997.044
Mass (kg)	59 221 676.5	94 432.755	59 221 676	94 719.18
Specific heat (kJ · kg ⁻¹ · C ⁻¹)	4.2	4.2	4.2	4.2
Mixed temperature (°C)[§]	18.03		4.03	

NOTES:

*Assumes source waters are thermally homogenous and mixing is complete and instantaneous

[†]Average flow conditions for the Saint John River and warm water discharge

[‡]Assumed all water is 100 % freshwater

[§] $t_m = (m_1 \times c_1 \times t_1 + m_2 \times c_2 \times t_2) \div (m_1 \times c_1 + m_2 \times c_2)$, where t_m = mixing temperature, m = mass of the water, c = specific heat of the water, and t = temperature of the water, $_1$ = Saint John River, $_2$ = Warm Water Discharge

Thus, green lights were applied to potential impacts to surface water physical quality and surface water biological quality during Project operation and maintenance (Table 51).

IPP contracted the Ocean, Coastal, and River Engineering Research Centre of the National Research Council (NRC) to conduct modelling and assessment of effluent discharge from the Mill on the Saint John River Estuary. A three-dimensional, numerical hydrodynamic model was developed in TELEMAC-3D to provided the basis for numerical simulations of effluent trajectories and dilution. The model extended about 60 km upriver to Evandale and 15 km downriver to the outer boundaries of Saint John Harbour. To better resolve the effluent plumes and the complex bathymetric features affecting local hydrodynamics in the area, the model was highly refined at Reversing Falls.

The numerical hydrodynamic model was used to evaluate far-field plume dilution characteristics from the MMO for the existing effluent discharge and the future effluent discharge when the ETF component of the Project is complete and operational. The existing conditions were modelled using an MMO discharge of 1.27 m³ · s⁻¹ at 51 °C and the future conditions (*i.e.*, after Project) were modelled using an MMO discharge of 0.8 m³ · s⁻¹ at 36 °C. The duration of each model simulation was 41 days to span two full spring-neap tidal cycles (*i.e.*, 30 days) and up to 11 days of model spin-up. The model was calibrated by adjusting model input variables and comparing the predicted water levels, velocities, and temperature / salinity profiles to measured values during Summer 2001. Additional details of the model setup, calibration, and validation can be found within Appendix XII.

The 1 067 mm diameter concrete MMO is located in an alcove adjacent to Reversing Falls (Figure 87 and Figure 88), which is a highly dynamic environment with high ambient flow speeds (*i.e.*, upwards of 8 m · s⁻¹) and is intensely turbulent with jet-like flow. The model demonstrates that highly turbulent regions and recirculating eddies form above and below Reversing Falls. Direction of the eddies reverse based on dominant flow direction (*i.e.*, ebb tide or flood tide as shown in Figure 89). It also suggests relatively quiescent areas within Lee Cove and Mill Cove where those eddies form.



Figure 87. Google Earth photograph showing the general location of the Main Mill Outfall at the Reversing Falls Mill in Saint John, New Brunswick.



Figure 88. Oblique Google Earth photograph showing the location of the Main Mill Outfall at the Reversing Falls Mill in Saint John, New Brunswick. Also shown are drone photographs showing the Main Mill Outfall.

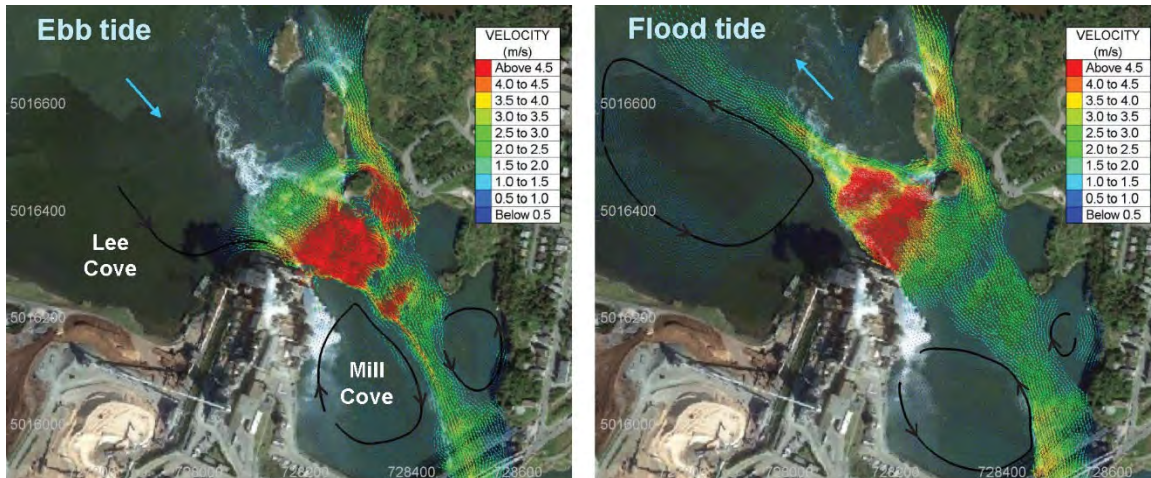

Figure 89. Water velocity profiles in the vicinity of the Reversing Falls Mill in Saint John, New Brunswick during an ebb tide and flood tide produced using the three-dimensional hydrodynamic model TELEMAC-3D.

The USEPA's plume modelling software CORMIX was used for delineating the steady-state effluent concentration snapshots from the MMO. Results indicate that mixing processes, which are driven by highly turbulent ambient flow conditions at Reversing Falls, dominate the behaviour and dilution of the MMO effluent. Modelling by the NRC suggests that under most conditions, the near-field region of the plume (*i.e.*, where the effluent plume behaviour and trajectory are predominantly governed by the momentum and buoyancy of the discharge relative to ambient conditions) terminates within 2.1 m of the MMO, except during slack tide when ambient flows are $< 0.2 \text{ m} \cdot \text{s}^{-1}$. During those instances, the near-field region of the plume extends about 40 m from the outfall. Results for the far-field region of the plume (*i.e.*, where the effluent plume behaviour and trajectory are predominantly governed by ambient advective processes and dispersive processes, such as tides, river discharges, and baroclinic effects) are discussed below.

Modelled results of the surface effluent plume dilution under existing and future conditions (*i.e.*, after Project) are shown in Figure 90. The results are presented for two slack tides (*i.e.*, 0 hrs and 7 hrs), during ebb tide (*i.e.*, 0.25 hrs, 1.0 hrs, and 3.25 hrs), and during flood tide (*i.e.*, 7.25 hrs, 7.5 hrs, and 12.25 hrs).

In both modelled scenarios, the plume has the greatest extent about 0.25 hrs in to an ebb tide when it extends about 300 m downstream of the MMO (Figure 90). Beyond that distance, the modelled effluent plume completely mixes with the River flow and concentrations are $< 1 \%$. As expected, under existing conditions, the modelled effluent plume extends slightly further from the MMO compared to when the Project is in operation (*i.e.*, when modelled flows are 38 % less).

Modelling also demonstrates that flows through Reversing Falls are so great that the plume hugs the Mill's shoreline regardless of the tidal conditions (*i.e.*, ebb or flood; Figure 90). The modelled plume does extend slightly further from the MMO during an ebb tide compared to a flood tide and suggests that the River's flow exerts a greater influence on plume extent.

Modelled results of the near-bed effluent plume dilution under existing and future conditions are shown in Figure 91. The results are presented for three slack tides (*i.e.*, 0 hrs, 7 hrs, and 12.4 hrs), during ebb tide (*i.e.*, 0.25 hrs), and during flood tide (*i.e.*, 7.5 hrs, 8.75 hrs, 11.5 hrs, and 12.25 hrs).

The extent of the near-bed plume is much smaller than the surface plume (*c.f.*, Figure 90 and Figure 91) and is because the effluent plume from the MMO is strongly buoyant as it comprises warm freshwater. In both modelled scenarios, the plume has the greatest extent at 12.4 hrs or slack tide when it extends about 200 m. Beyond that distance, the modelled effluent plume completely mixes with the River flow and concentrations are < 1 %. As expected, under existing conditions, the extent of the modelled effluent plume is slightly greater compared to when the Project is in operation (*i.e.*, when modelled flows are 38 % less).

Unlike the surface plume modelling results, the near-bed effluent plume extends further during a flood tide than during an ebb tide (*c.f.*, Figure 90 and Figure 91). Like the results observed for the surface plume modelling, the near-bed plume hugs the Mill's shoreline regardless of tidal conditions.

Similar overall patterns of surface and near-bed plume behaviour were predicted for the many different river flow and tidal range conditions simulated. Insignificant changes in plume concentrations were observed depending on the relative strength of river and tidal flows. A green light was applied to the impact on surface water chemical quality during Stage III (Table 51).

Through this Project, freshwater drawn from the Spruce Lake Watershed and subsequently discharged to the brackish Saint John River will reduce by up to 50 %. This is considered a positive impact because it reduces the volume of water transferred from one watershed to another and it reduces the flow through Reversing Falls albeit low compared to the overall flow. This might yield other benefits, such as increased water levels within the Spruce Lake Watershed during periods of low flow / drought sometimes experienced in the summer (*n.b.*, this could lead to indirect benefits, such as increased water levels for recreational users of waterways within the Watershed). Therefore, a green light was also applied to the impact of the Project during operation and maintenance on surface water quantity.

As described in Section 2.7.1.4.4, a diversion tank will be incorporated within the ETF. This will allow operators to divert effluent in the event of an extreme upset event, such as a spill or an effluent surge. This, combined with the higher quality effluent produced should be beneficial with respect to potential impacts of contamination by hydrocarbons / hazardous chemicals. That is why a green light was applied during Stage III within Table 51.

Modelled Existing Surface Plume Dilution

Effluent Discharge = 1.27 m³/s

Temperature = 51°C

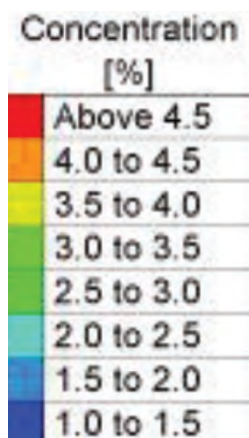
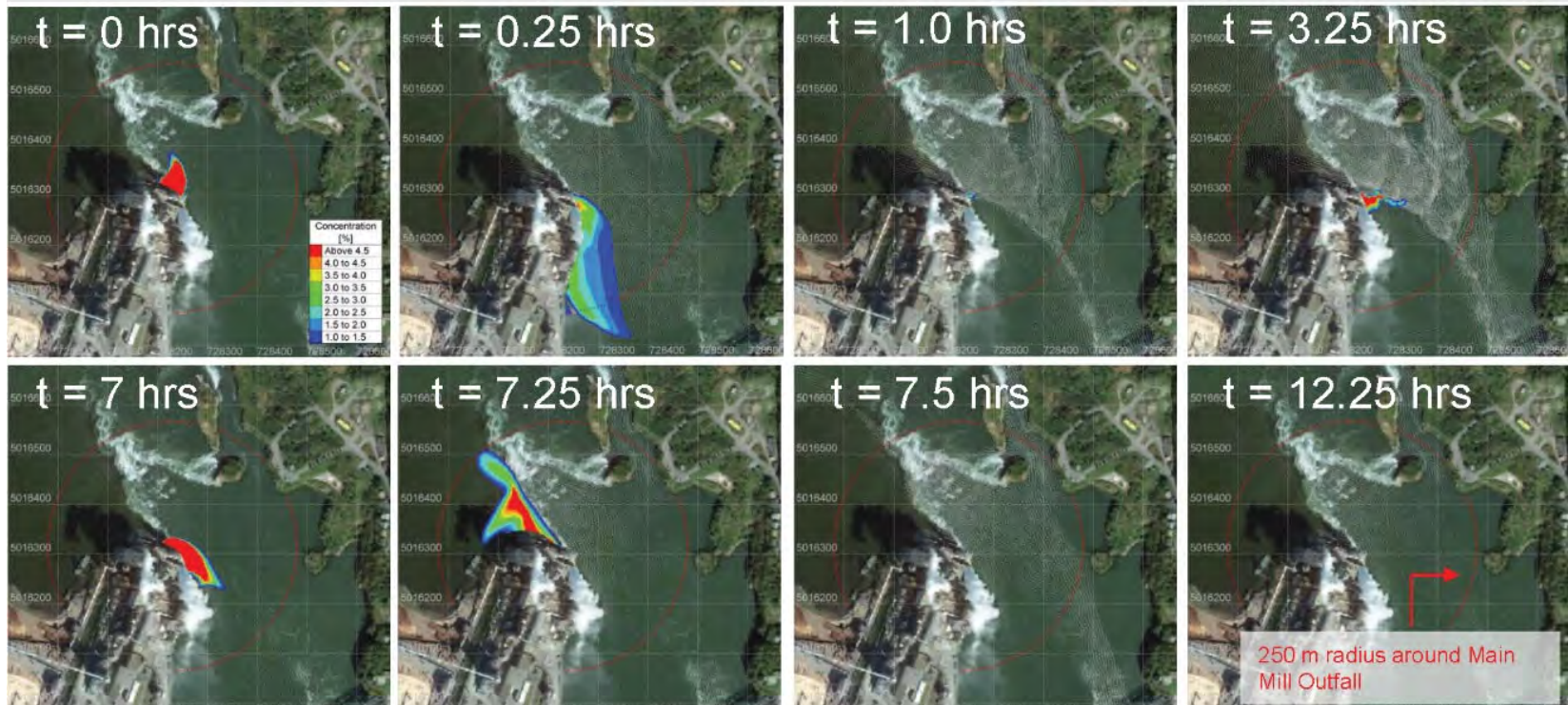
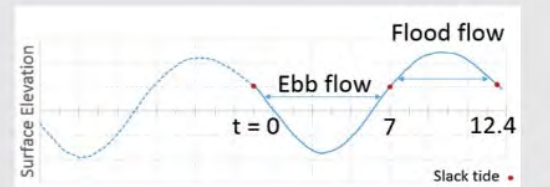

Modelled After Project Surface Plume Dilution

Effluent Discharge = 0.8 m³/s

Temperature = 36°C

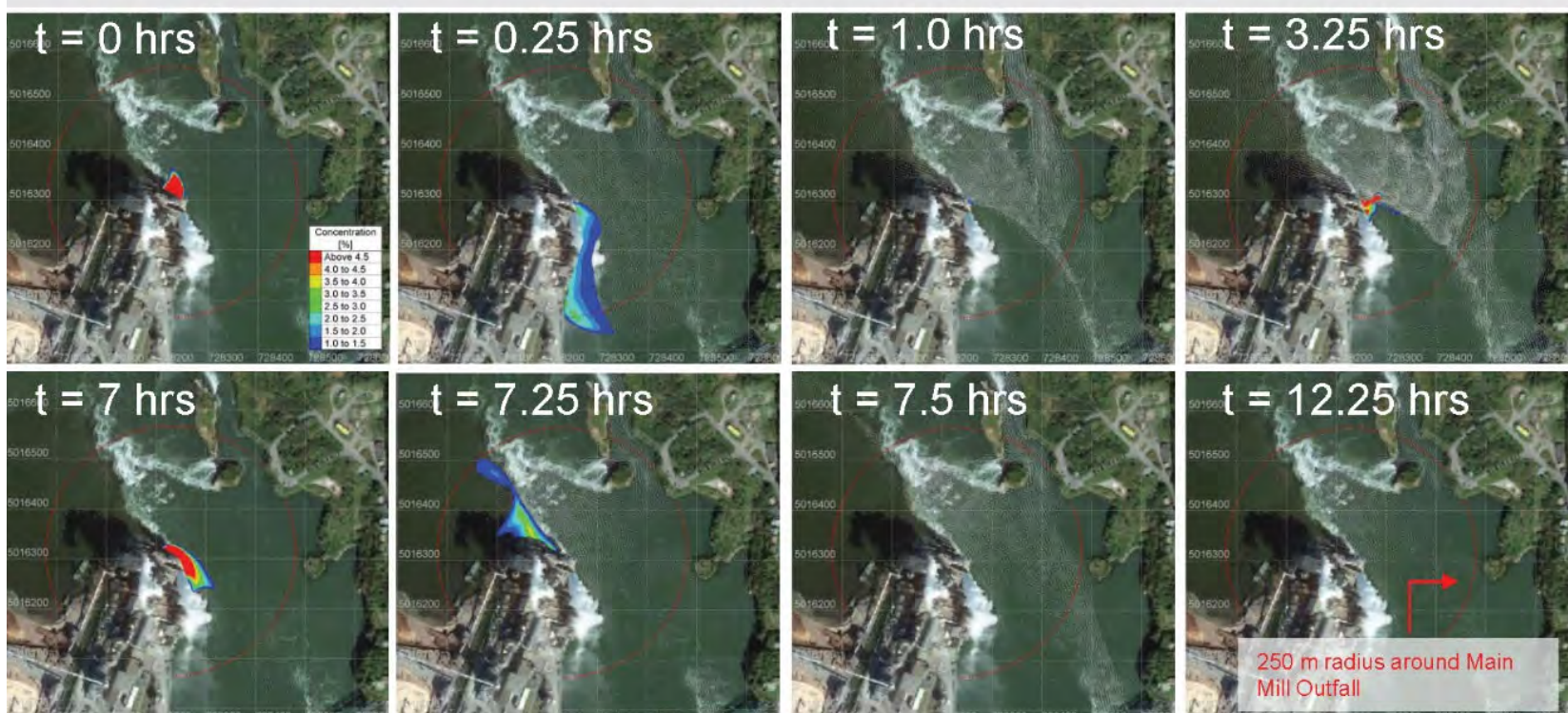
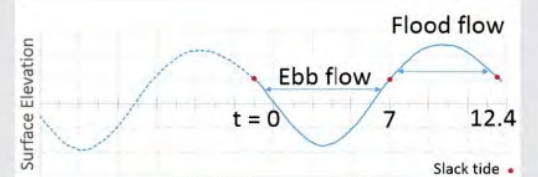
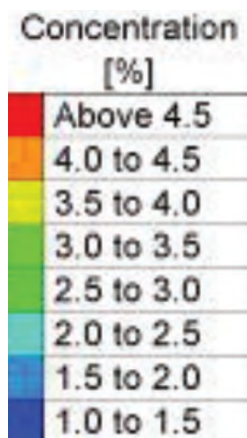
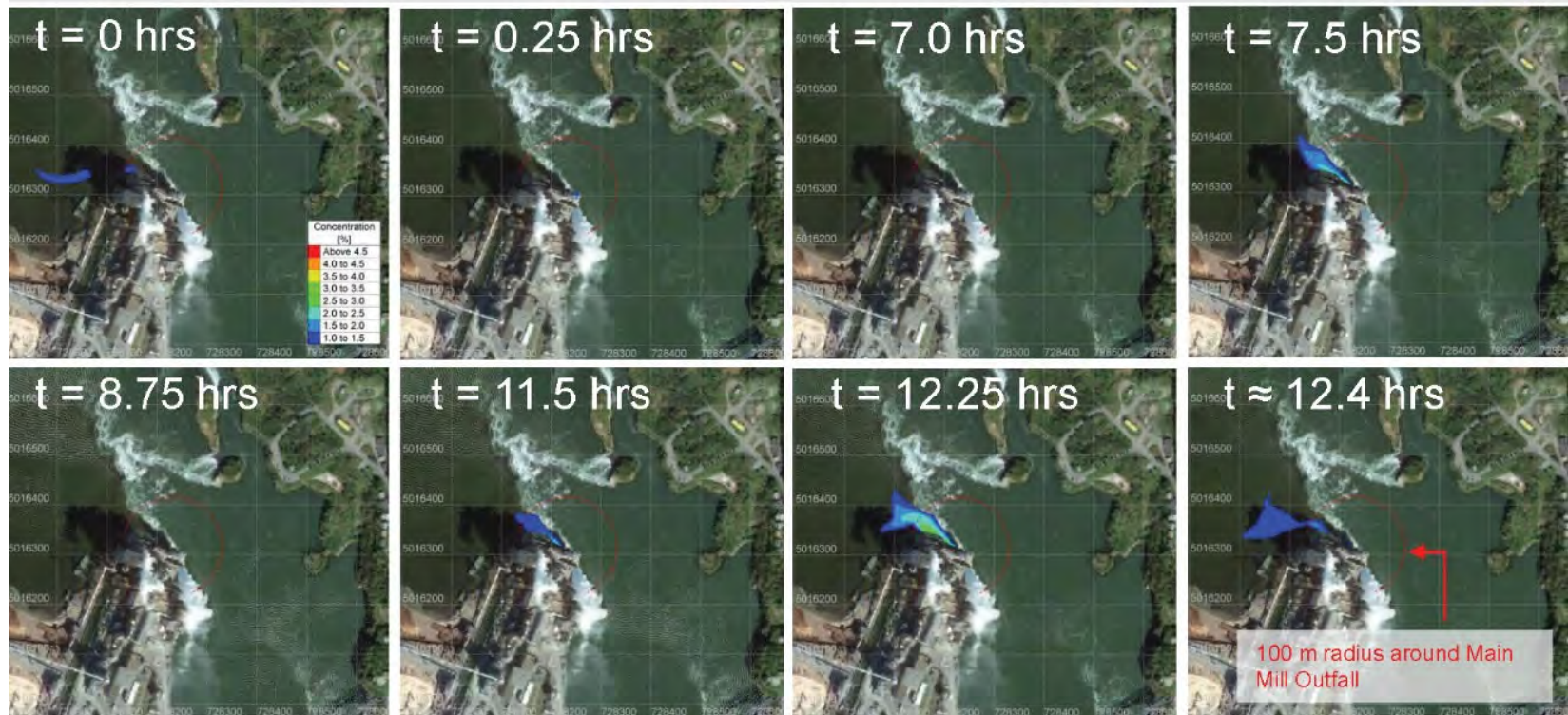
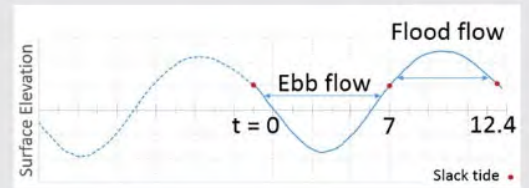

Figure 90. Steady-state surface effluent plume dilution snapshots following discharge from the Main Mill Outfall of the Reversing Falls Mill in Saint John, New Brunswick modelled under existing conditions and after the environmental treatment facility and water use reduction project is in operation.

Modelled Existing Near-Bed Plume Dilution

Effluent Discharge = 1.27 m³/s

Temperature = 51°C



Modelled After Project Near-Bed Plume Dilution

Effluent Discharge = 0.8 m³/s

Temperature = 36°C

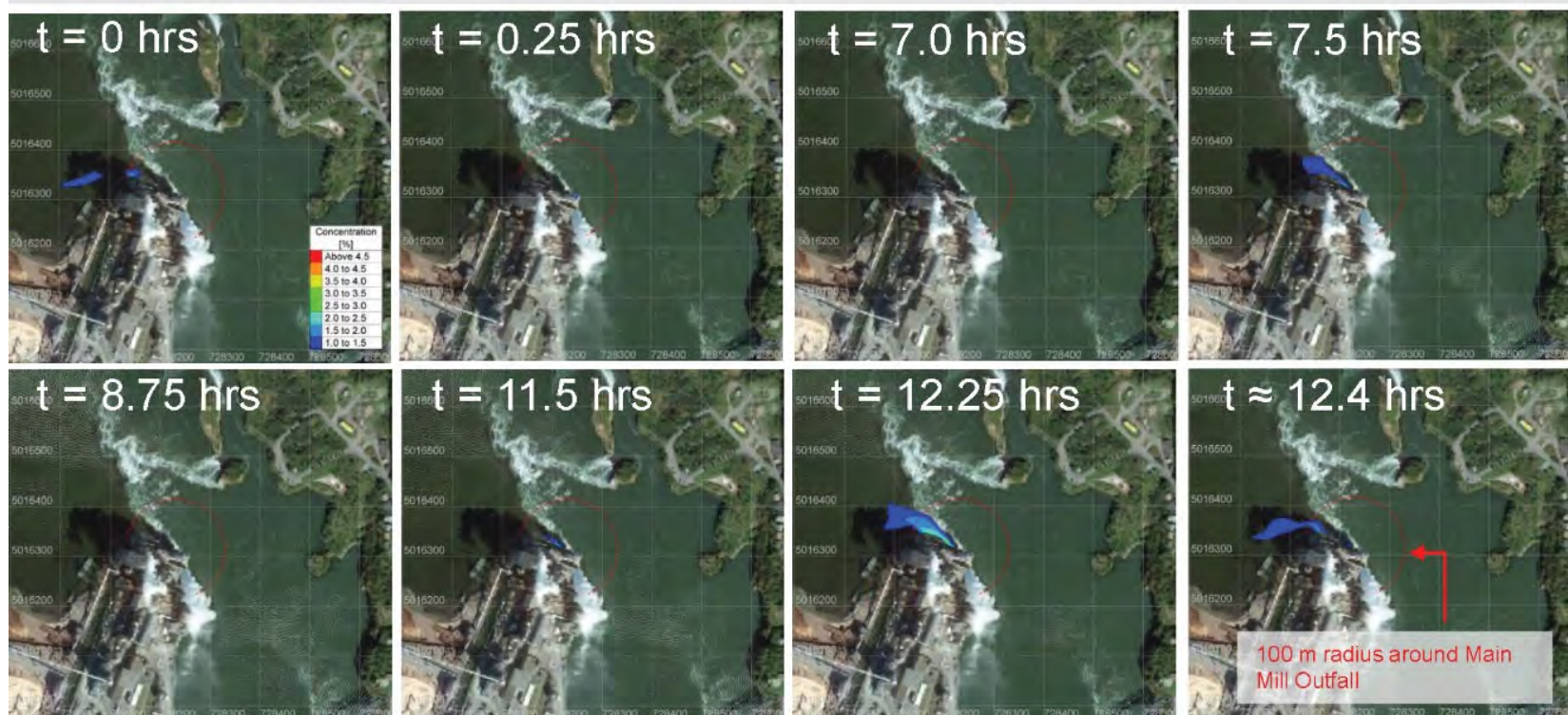
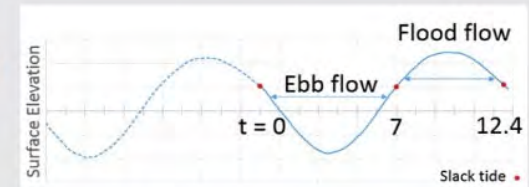

Figure 91. Steady-state near-bed effluent plume dilution snapshots following discharge from the Main Mill Outfall of the Reversing Falls Mill in Saint John, New Brunswick modelled under existing conditions and after the environmental treatment facility and water use reduction project is in operation.

All but one of the potential impacts ($n = 4$) during Project Stage V were assigned yellow lights (Table 51). Those impacts were assigned yellow lights because a short duration release of effluent outside regulatory limits could considerably affect the receiving water body. The other potential impact, surface water quantity, was assigned a green light.

4.4.2.3.3 Proposed Mitigation

The mitigation measures listed below should be employed to minimize the chance of activities related to the Project from affecting surface water environs through the introduction of hydrocarbons and hazardous chemicals and contaminants.

- A Project-specific environmental protection plan will be developed to provide best-management practices that all Project personnel should follow in order to limit the potential for impacts to the surface water environment to occur. {Applicable to Stages II, III, and V}
- All Project personnel should be briefed on the potential impacts the Project may have on surface water quality and quantity; this could range from explaining that soil erosion may increase due to vegetation removal, to possible contamination by hydrocarbons due to spills. {II, III, and V}
- Mitigation measures developed for this Project should be adhered to in order to adequately address potential impacts on surface water quantity and quality. {II, III, and V}
- An erosion and sedimentation control plan, which may form part of the Project-specific environmental protection plan, should be developed and implemented prior to completing any onsite works and may include the installation and management of structures, such as strawbale barriers, rock check dams, silt fences, *etc.*, to limit and control erosion and sedimentation. {II}
- Erosion and sediment control structures should be regularly inspected and maintained according to the Project-specific environmental protection plan to ensure they continue to protect against erosion and sedimentation. {II}
- A surface water drainage management plan, which may form part of the Project-specific environmental protection plan, should be developed and implemented prior to completing any onsite works and may include the use of ditches and settling basins to control surface water flow and to reduce sediment concentrations in water prior to discharge from the site. {II}
- Material stockpiles should be located at least 30 m from the Saint John River. {II}
- Material stockpiles should not be located in areas where there is a concentration of surface water runoff. Perimeter erosion control, such as silt fencing, should be erected around material stockpiles to protect them from surface water runoff. {II}
- During construction activities, all sanitary waste associated with those construction activities should be collected using self-contained portable washroom facilities and those wastes should be handled and disposed of by a licensed waste disposal operator. {II, III}
- Trenching and ditching may be required at the base of any large rock faces that are created in order to collect and direct any groundwater discharge from the rock faces. {II}
- All heavy equipment used onsite should be in good repair and free of excess oil and grease, the equipment should be equipped with appropriately-sized spill

- response equipment (*i.e.*, spill kits), all Project personnel will be trained in the use of such equipment, and the equipment should be regularly maintained and inspected to minimize the risk of hydrocarbon-based fluid spills that may pose a threat to the Saint John River. {II}
- Concrete slurry wastes should not be allowed to spill on to the ground and concrete equipment should only be washed up in designated areas where concrete wastes can set, be broken up, and subsequently disposed of appropriately. To do this, temporary concrete washout facilities should be constructed using an impermeable liner and designed and maintained in sufficient quantity and size to contain all liquid and concrete waste generated by onsite washout operations. {II and III}
 - Construction debris, surplus materials, and other solid waste materials should not be disposed of onsite (*n.b.*, this does not apply to excavated soils and rock) and waste receptacles / bins should be made available for containing construction debris and other solid waste materials for temporary storage before offsite disposal at an approved facility. {II and III}
 - Road sweeping units should be equipped with sediment collection hoppers to limit the spread of contaminants that could possibly be entrained in surface water runoff and be subsequently introduced to Saint John River. Should dust suppression be required, the preferred method of control is by applying water. {II}
 - Sand should be used for winter roadway maintenance instead of salt because the majority of sand can be collected through roadway sweeping whereas salt dissolves in water and can be more easily introduced to the Saint John River. {II}
 - Vehicle speeds on the site should be limited to that necessary to limit the generation of dusts. {II}
 - Designated refueling locations should be identified within the Project-specific environmental protection plan (*e.g.*, > 30 m from the edge of watercourse, *etc.*) and those locations should be equipped with appropriately stocked and maintained spill response equipment (*i.e.*, spill kits). Refueling should only be done by trained and competent personnel using a means of spill containment, such as completing the operation atop an impermeable liner or using spill collection pans. Any materials used to clean-up spills, contaminated materials, and recovered spilled material that is not suitable for reuse should be stored and disposed of appropriately. {II}
 - All potential contaminants and contaminated materials will be stored in a contained area where they cannot become mobilized or access the ground surface (*i.e.*, be placed atop and within spill containment pads). {II}
 - Regular maintenance and inspection of equipment onsite should be performed to minimize the risk of spills of oil based fluids that pose a threat to the Saint John River. {II}
 - All spills of hazardous materials should be reported immediately to the appropriate Regulator(s). {II}
 - Throughout operations, monitoring of effluent quality should be undertaken by IPP personnel and / or accredited third-party laboratories to assess quality of the treated effluent and compliance with regulations. {III}
 - Water quality sampling, which is focused on the final effluent discharge from the Main Mill Outfall, should be conducted once the Project is in operation to validate that the effluent data input to the three-dimensional hydrodynamic plume model was appropriate or needs to be adjusted. {III}

- Operators should ensure that if an upset event occurs, effluent is directed to the diversion tank until the effluent can be treated appropriately. {III}
- Emergency response / contingency plans should be designed to prevent any major and / or sustained environmental damage during any errors, mishaps, and / or unforeseen events. {V}

4.4.2.3.4 Potential Post-Mitigation Residual and Cumulative Impacts

No residual and cumulative effects are likely to occur to the surface water so long as the mitigation measures provided here are followed.

4.4.2.4 Groundwater Quality and Quantity

Groundwater is a resource used for supplying some potable water in the local area. Many of the residential, commercial, institutional, and industrial properties in west Saint John are supplied potable water that is obtained from the South Bay Wellfield, which is located about 3 km distant from the Mill. Although the City of Saint John's municipal water distribution system extends to most areas of Milford, there are some areas that are not connected (*i.e.*, refer to Section 3.3.8). Those properties rely on individual groundwater wells to supply potable water (*i.e.*, refer to Section 3.1.7).

Groundwater discharge provides baseflow to local and regional watercourses during periods of little precipitation. Wetlands serve as areas of groundwater discharge and recharge depending on their geographical context. Together, watercourses and wetlands in communication with the groundwater environment form part of the structure and function of the natural ecosystem (*i.e.*, through the hydrological cycle and nitrogen cycle).

For the above noted reasons, groundwater was selected as a VEC requiring assessment.

4.4.2.4.1 Conceivable Impacts and Pathways

Based on Fundy Engineering's experience in the area, there is generally moderate communication between surface water and groundwater systems. Some activities that occur at the surface could impact the groundwater system in the absence of mitigation measures. Therefore, it is important to consider potential impacts and their pathways to the groundwater environment. In particular, it is important to consider aquifer sustainability in terms of water quantity and aquifer health in terms of water quality.

Activities and physical works that may occur during the Project and their potential impacts on the groundwater environment are summarized in Table 48. In the section that follows, the potential impacts are assessed in concert with the development of mitigation measures.

Table 48. The type of cause-effect relationships that are possible and the mechanisms by which stressors could ultimately lead to impacts on the groundwater environment during various activities associated with the proposed environmental treatment facility and water use reduction project at the Reversing Falls Mill in Saint John, New Brunswick.

Activity	Conceivable Impacts and Pathways
Vegetation clearing, grubbing, stripping, grading, and landscaping	<ul style="list-style-type: none"> ➤ Increased erosion potential whereby exposed sediments may be entrained in overland flow and subsequently transported to the aquifer (<i>n.b.</i>, this is more of a potential concern for fractured bedrock systems where entrained sediments may not be filtered out during infiltration) ➤ Altered overland flow conditions (<i>i.e.</i>, timing, duration, and frequency) due to changes in slope, removal of vegetation, ditching, <i>etc.</i> may cause water to be quickly dispersed such that it does not have an opportunity to infiltrate to the aquifer (<i>i.e.</i>, reduction in quantity of water directed to the aquifer) ➤ Runoff from stockpiled spoils may contain increased sediment loads that are subsequently transported to the aquifer ➤ Loss of vegetation may result in a change in the nutrients and chemical species being introduced to the subsurface
Rock breaking and excavating with pneumatic hammers	<ul style="list-style-type: none"> ➤ Sediment may be dislodged within rock fractures and may become entrained in groundwater if ground vibrations are excessive ➤ Creation and exposure of large rock faces at the edge of excavations may be new sources of groundwater discharge (<i>i.e.</i>, seepage faces) ➤ Runoff from stockpiled shot rock and excavated rock may contain increased sediment loads that are subsequently transported to the aquifer
Operation and maintenance of heavy equipment	<ul style="list-style-type: none"> ➤ Ground spills of hydrocarbons during refueling operations (<i>i.e.</i>, gasoline and diesel) may infiltrate to the aquifer ➤ Leaks of hydraulic fluids, oils, <i>etc.</i> during normal operations may spill on to the ground and infiltrate to the aquifer
Temporary construction personnel sanitary facilities	<ul style="list-style-type: none"> ➤ Leaks or spills on the ground during use or maintenance may cause untreated sanitary waste to infiltrate to the aquifer
Storage and handling of various hazardous chemicals	<ul style="list-style-type: none"> ➤ Leaks or spills on the ground during the handling and storage of hazardous chemicals (<i>e.g.</i>, paint, epoxies, concrete additives, cleaners, solvents, <i>etc.</i>) may infiltrate to the aquifer
Foundation construction and roadway paving	<ul style="list-style-type: none"> ➤ Dewatering activities may cause sediment to be entrained in discharged water that could be subsequently transported to the aquifer ➤ Foundations and asphalt roadways / parking areas are impermeable surfaces, which may be placed in areas that were formerly groundwater recharge or discharge areas (<i>i.e.</i>, change in quantity of water directed to the aquifer)
Dust suppression and winter roadway clearing	<ul style="list-style-type: none"> ➤ If chemical dust suppressants are used on roadways, they may be entrained in overland flow and subsequently transported to the aquifer ➤ If salt is used for winter roadway maintenance, it may be entrained in overland flow and subsequently transported to the aquifer
Temporary storage of construction and hazardous waste	<ul style="list-style-type: none"> ➤ Precipitation may come in contact with construction and hazardous waste that is temporarily stored onsite prior to safe disposal, which may cause water to become contaminated and subsequently infiltrate to the aquifer

Regardless of how stringent the implemented mitigation measures are, there is always a potential for mishaps, errors, and / or unforeseen events to occur. The primary concern for groundwater is contamination by hydrocarbons and / or hazardous materials.

Because various Project activities have the potential to impact the groundwater environment, it was identified as a VEC that required assessment. Based on the conceivable impacts and pathways identified in Table 48, the following specific potential impacts were assessed:

- groundwater quality;
- groundwater quantity;
- hydrocarbon / hazardous chemical contamination;
- groundwater recharge areas; and
- groundwater discharge areas.

Impacts to hydrogeology may have secondary effects that induce changes in other VECs. Those secondary effects are dealt with in the assessment of the other VECs. For example, changes in groundwater discharge or recharge may affect fish and fish habitat, which are assessed under the Aquatic Flora and Fauna VEC.

4.4.2.4.2 Potential Impacts

Results of the groundwater quantity and quality impact assessment are provided in Table 52. Six yellow lights were applied to the potential impacts and are largely related to groundwater quality and potential spills of hydrocarbons and hazardous chemicals. It is realized that contamination may occur to the groundwater system and potential impacts could be long-lasting depending on the degree of the spill and the initial clean-up efforts. All other potential impacts were either assigned green lights ($n = 3$) or no change lights ($n = 6$).

4.4.2.4.3 Proposed Mitigation

The mitigation measures listed below should be employed to minimize the chance of Project activities from impacting the groundwater regime (*n.b.*, many of the mitigation measures are nearly identical to those provided for surface water protection and is because the two systems are often interconnected).

- A Project-specific environmental protection plan will be developed to provide best-management practices that all Project personnel should follow in order to limit the potential for impacts to the groundwater environment to occur. {Applicable to Stages II, III, and V}
- All Project personnel should be briefed on the potential impacts that the Project could have on ground water quality. {II, III, and V}
- Mitigation measures developed for this Project should be adhered to in order to adequately address potential impacts on groundwater quantity and quality. {II, III, and V}
- An erosion and sediment control plan, which may form part of the Project-specific environmental protection plan, will be developed and implemented prior to completing any onsite works and may include the installation and management of structures, such as strawbale barriers, rock check dams, silt fences, *etc.*, to limit and control erosion and sedimentation. {II}
- Erosion and sediment control structures will be regularly inspected and maintained according to the Project-specific environmental protection plan to ensure they

- continue to protect against erosion and sedimentation. {II}
- A surface water drainage management plan, which may form part of the Project-specific environmental protection plan, will be developed and implemented prior to completing any onsite works and may include the use of ditches and settling basins to control surface water flow and reduce sediment concentrations in water prior to discharge from the site. {II}
 - All heavy equipment used on site should be in good repair and free of excess oil and grease, the equipment should be equipped with appropriately-sized spill response equipment (*i.e.*, spill kits) and all Project personnel will be trained in the use of such equipment, and the equipment should be regularly maintained and inspected to minimize the risk of hydrocarbon-based fluid spills that may pose a threat to groundwater systems. {II, III, and V}
 - Concrete slurry wastes should not be allowed to spill on to the ground and concrete equipment should only be washed up in designated areas where concrete wastes can set, be broken up, and subsequently disposed of appropriately. To do this, temporary concrete washout facilities should be constructed using an impermeable liner and designed and maintained in sufficient quantity and size to contain all liquid and concrete waste generated by onsite washout operations. {II}
 - Construction debris, surplus materials, and other solid waste materials should not be disposed of onsite (*n.b.*, this does not apply to excavated soils and rock) and waste receptacles / bins should be made available for containing construction debris and other solid waste materials for temporary storage before offsite disposal at an approved facility. {III}
 - Material stockpiles should not be located in areas where there is a concentration of surface water runoff and perimeter erosion control, such as silt fencing, should be erected around material stockpiles to protect them from surface water runoff. {II}
 - Road sweeping units should be equipped with sediment collection hoppers to limit the spread of contaminants that could possibly be entrained in surface water runoff and be subsequently introduced to groundwater systems. Should dust suppression be required, the preferred method of control is by applying water. {II, III, and V}
 - Sand should be used for winter roadway maintenance instead of salt because the majority of sand can be collected through roadway sweeping whereas salt dissolves in water and can be more easily introduced to groundwater systems. {II, III, and V}
 - Vehicle speeds on the site should be limited to that necessary to limit the generation of dusts. {II, III, and V}
 - Connection to alternative water supplies, such as a municipal distribution system, is most often required when an aquifer is contaminated. {II, III, and V}
 - During construction activities, all sanitary waste associated with those construction activities should be collected using self-contained portable washroom facilities and those wastes should be handled and disposed of by a licensed waste disposal operator. {II}
 - Designated refueling locations should be identified within the Project-specific environmental protection plan (*e.g.*, > 30 m from the edge of watercourse, *etc.*) and those locations should be equipped with appropriately stocked and maintained spill response equipment (*i.e.*, spill kits); refueling should only be done by trained and competent personnel using a means of spill containment, such as completing

the operation atop an impermeable liner or using spill collection pans. Any materials used to clean-up spills, contaminated materials, and recovered spilled material that is not suitable for reuse should be stored and disposed of appropriately. {II}

- All potential contaminants and contaminated materials will be stored in a contained area where they cannot become mobilized or access the ground surface (*i.e.*, be placed atop and within spill containment pads). {II, III, and V}
- Regular maintenance and inspection of equipment on site should be performed to minimize the risk of spills of oil based fluids that pose a threat to groundwater systems. {II, III, and V}
- All spills of hazardous materials should be reported immediately to the appropriate Regulator(s). {II, III, and V}

4.4.2.4.4 *Potential Post-Mitigation Residual Impacts*

If a spill migrates to the groundwater system, the potential impacts could be long lasting because groundwater environments are complex and often difficult to remediate. This is an extremely remote possibility because of the stringent environmental protection measures used onsite under IPP's existing EMS and through the environmental protection measures that will be set forth in the Project-specific EPP.

Table 49. Assessment of potential impacts on air quality of the proposed environmental treatment facility and water use reduction project at the Reversing Falls Mill in Saint John, New Brunswick.

Potential Impact	Stage II: Construction			Stage III: Operation and Maintenance			Stage V: Mishaps, Errors, and / or Unforeseen Events		
	Degree of Impact	Pathways	Mitigation	Degree of Impact	Pathways	Mitigation	Degree of Impact	Pathways	Mitigation
Micro-climate (<i>i.e.</i> , temperature and humidity)	⊖			⚠	4	P, Q	⊖		
CO emissions	⚠	1, 2	A to K	⚠	5, 6, 7	A to K, R	⚠	10	A, B, C, W
NO _x emissions	⚠	1, 2	A to K	⚠	5, 6, 7	A to K, R	⚠	10	A, B, C, W
SO ₂ emissions	⚠	1, 2	A to K	⚠	5, 6, 7	A to K, R	⚠	10	A, B, C, W
VOC emissions	⚠	1, 2	A to K	⚠	5, 6, 7	A to K, R	⚠	10	A, B, C, W
PM emissions (<i>e.g.</i> , exhausts and dusts)	⚠	1, 2, 3	A to O	⚠	5, 6, 7	A to N	⚠	10	A, B, C, W
Airborne bacteria	⊖			⊖	8, 9	S to V	⊖	8, 9	S to X













PATHWAYS

- 1 – An increase in personal and construction vehicles could impact the local air quality through the emission of combustion gases.
- 2 – Construction equipment is a major source of combustion emissions which potentially will have an effect on local air quality. During the 27 month construction period, it is estimated that about 6 900 tonnes CO_{2eq} of greenhouse gases will be emitted.
- 3 – Fugitive dusts may be generated while clearing trees, moving materials, and operating vehicles on dirt and gravel roadways / surfaces.
- 4 – The microclimate in the immediate vicinity of the indirect air coolers will be affected by the evaporative cooling process (*i.e.*, air temperatures will be higher and humidity levels may sometimes be higher in a zone around the indirect air coolers). The zone of impact is expected to be small as the volume of air going through the systems is small compared to the size of the local airshed.
- 5 – About five full-time permanent employees will be required to operate and maintain the environmental treatment facility (*i.e.*, one operator per shift), which will not perceptibly change the greenhouse gas emissions in the local area.
- 6 – Deliveries of product (*e.g.*, polymers, acids, *etc.*) for operating the environmental treatment facility will be minimal, which will not perceptibly change the GHG emissions in the local area.
- 7 – To operate the Project, it is estimated that an additional 4 MW of electricity per day will have to be purchased from NB Power. Purchasing 4 MW of electricity per day from NB Power, travel by the Project operators, and transporting the solids / fibre to the compost facility will result in the emission of about 450 tonnes per year CO_{2eq} of greenhouse gases.
- 8 – In New Brunswick, some airborne bacteria disease outbreaks have been linked to industrial direct cooling towers.
- 9 – Direct cooling towers can release aerosolized water to the atmosphere and if bacteria are present, the aerosolized water can spread the bacteria over several kilometers.
- 10 – In the event of an emergency, equipment with pollutant reduction technologies may not be readily available; however, it will be more important to correct the mishap, error, and / or unforeseen event.

MITIGATION

- A – A Project-specific environmental protection plan will be developed to provide best-management practices that all Project personnel should follow in order to limit the potential for impacts to air quality to occur.
- B – All Project personnel should be briefed on the potential impacts that equipment emissions can have on the quality of the local airshed and briefing information should range from describing emissions that are released from equipment during operation to how those emissions can be reduced.
- C – Mitigation measures developed and included in the Project-specific environmental protection plan should be adhered to in order to adequately address potential impacts.
- D – Construction, operation, and maintenance equipment should only be operated at optimum loading rates.
- E – Heavy equipment should be turned off when not in use and / or when practical (*i.e.*, anti-idling policy).
- F – The number of vehicle kilometers travelled should be kept to a minimum (*i.e.*, there should be no unnecessary operation of equipment in and around the site).
- G – Heavy equipment should be operated using clean fuels (*i.e.*, ultra-low sulphur diesels), where available and practical.
- H – Heavy equipment exhaust emission systems should meet the recommended standards.
- I – Equipment should be maintained according to manufacturer recommended servicing periods.
- J – Heavy equipment should be refueled using a protocol designed to mitigate environmental risks.
- K – No solid waste should be burned onsite.
- L – Construction, operation, and maintenance vehicles should comply with the posted / recommended speed limits and, as appropriate, reduce speed when travelling on surfaces where dusts are generated (*i.e.*, gravel or dirt roadways).
- M – If the application of water as a dust suppressant is deemed necessary on local gravel roadways (*n.b.*, this is the preferred method of dust suppression), it should be applied using suitable equipment (*e.g.*, a tanker truck equipped with spray bars and methods of controlling water flow, *etc.*).
- N – Material stock piles (*e.g.*, soil, sand, aggregate, *etc.*) and spoils piles should be sited in locations that minimize the impact from prevailing winds.
- O – Allowing vegetation to re-establish itself should reduce impacts to air quality, especially those associated with fugitive dusts generated from wind blowing over bare soils.
- P – The indirect air coolers, which are an indirect cooling technology, should be operated as per the manufacturer's recommendations to ensure they operate efficiently.
- Q – Planting vegetation or allowing vegetation, including grasses, shrubs, and trees, to regenerate / grow, can moderate the micro-climate changes at the Project site. This could include planting additional trees and bushes along the landscaped berm.
- R – If possible, recovered fibre and / or dewatered solids should be incinerated in the onsite power boiler to generate electricity and offset that required for purchase from NB Power.
- S – The indirect air coolers should be registered with the City of Saint John when applying for the Project's building permit.
- T – The plume abatement systems of the indirect air coolers should be in operation and, where possible, the indirect air coolers should be operated in a dry mode during winter months.
- U – ASHRAE Standard 188-2018 should be followed.
- V – Regular monitoring of microorganisms should be undertaken when the indirect air coolers are operational.
- W – Emergency response and contingency plans should be designed to prevent any major and / or sustained environmental damage during any errors, mishaps, and / or unforeseen events.
- X – A contingency response plan should be developed to monitor, control, and eliminate bacteria growth.

Table 50. Assessment of potential impacts on sound emissions of the proposed environmental treatment facility and water use reduction project at the Reversing Falls Mill in Saint John, New Brunswick.

Potential Impact	Stage II: Construction			Stage III: Operation and Maintenance			Stage V: Mishaps, Errors, and / or Unforeseen Events		
	Degree of Impact	Pathways	Mitigation	Degree of Impact	Pathways	Mitigation	Degree of Impact	Pathways	Mitigation
Sound pressure levels (<i>i.e.</i> , intensity)		1 to 5	A to M					1, 8	A to G, N
Sound duration		6	A to M					1, 8	A to G, N
Sound repetition		1, 2, 4, 5	A to M					1, 8	A to G, N
Ground vibration		1, 7	A to M					1, 8	A to G, N

PATHWAYS

- 1 – The heavy equipment planned for constructing the Project may emit sound at levels less than or greater than those currently emitted during normal Mill operations. That heavy construction equipment may also cause ground vibrations.
- 2 – Back-up alarms on heavy equipment used during Project construction will emit sounds around 120 dBA. The use of those alarms will be intermittent and similar to the alarms on loaders, bulldozers, and other heavy equipment currently used at the Mill site for normal operations.
- 3 – Although the site is almost devoid of vegetation, removal of remaining vegetation and grading within the Project footprint may affect the attenuation of sounds from the Project site.
- 4 – About 150 steel piles will be driven into the subsurface as part of the structural foundations for this Project. Pile driving emits loud and repetitive sounds, which can be annoying for nearby human receptors.
- 5 – Pneumatic hammers may be required to break up bedrock during excavation of the Project site for erecting the environmental treatment facility. Instantaneous impulse sounds from pneumatic hammers are generally < 100 dBA. Rock breaking with pneumatic hammers typically emits repetitive sounds that can be annoying to nearby human receptors.
- 6 – Sound levels as a result of the Project will be intermittent during construction; regular work hours will normally occur from 7 AM to 7 PM Monday through Friday.
- 7 – Ground vibrations are generated by heavy equipment travelling across the ground surface, pile driving causes ground vibration as the hammer forces the steel pile into the subsurface and rock breaking with pneumatic hammers causes ground vibrations as the hammer repeatedly comes into contact with the rock.
- 8 – Equipment brought in to mitigate any mishaps, errors, and / or unforeseen events may not have appropriate noise dampening measures or vibration reduction devices, but their operation would be expected to be of short duration.

MITIGATION

- A – A Project-specific environmental protection plan will be developed to provide best-management practices that all Project personnel should follow in order to limit the potential for impacts to the sound environment to occur.
- B – All Project personnel should be briefed on the potential impacts the Project may have on sound and sound levels; this could range from explaining that daily inspections and regular maintenance should be done on all heavy equipment to ensure they running as designed and are not unnecessarily contributing to construction noise.
- C – Mitigation measures developed and included in the Project-specific environmental protection plan should be adhered to in order to adequately address potential impacts.
- D – Project personnel should ensure that all equipment is equipped with the appropriate manufacturer designed sound level abatement equipment (*i.e.*, mufflers and shrouds).
- E – The exhaust systems of all Project equipment should be inspected regularly (*i.e.*, daily or weekly) to ensure that sound level abatement equipment is operating properly.
- F – Equipment should be maintained according to manufacturer's recommended servicing periods.
- G – The idling of all heavy equipment should be kept to a minimum and excessive engine throttling should be avoided.
- H – Engineered controls should be implemented to reduce sound levels emitted from equipment (*i.e.*, shrouds and barriers) and at the source to reduce vibrations that can be transferred to the ground surface and propagate outwards (*i.e.*, cushions and dampening pads).
- I – Loud construction activity (*e.g.*, pile driving and rock breaking, *etc.*) should be scheduled / planned to occur during normal workday / daylight hours (*i.e.*, 7 AM through 7 PM Monday through Saturday), where possible, to limit any potential annoyance to residential receptors. Loud activities should be scheduled to occur concurrently and all loud activity should conform to the City of Saint John's By-Law Respecting the Prevention of Excessive Noise in the City of Saint John [M-22].
- J – Nearby residents and businesses should be notified one week prior to the start of pile driving activities.
- K – The pile driver should be equipped with the appropriate manufacturer designed sound emission abatement equipment and, where practical, shrouds should be used to help minimize sounds emitted from pile driving activity.
- L – Where possible, hydraulic impact pile drivers should be used instead of conventional diesel drop hammers in order to reduce sounds emitted from pile driving activity.
- M – A protocol should be developed for receiving, investigating, managing, and tracking residential complaints in a timely manner regarding sound and vibrations emitted from the Project site.
- N – In the event of an emergency, equipment with proper sound abatement technologies may not be readily available. What will be more important at this stage is correcting the error, mishap, and / or unforeseen event to limit any and all permanent environmental impact(s).

Table 51. Assessment of potential impacts on surface water quantity and quality of the proposed environmental treatment facility and water use reduction project at the Reversing Falls Mill in Saint John, New Brunswick.

Potential Impact	Stage II: Construction			Stage III: Operation and Maintenance			Stage V: Mishaps, Errors, and / or Unforeseen Events		
	Degree of Impact	Pathways	Mitigation	Degree of Impact	Pathways	Mitigation	Degree of Impact	Pathways	Mitigation
Surface water physical quality (<i>i.e.</i> , turbidity, suspended sediment and temperature)		1, 2, 3	A to H		11, 12	A, B, C, U		19	A, B, C, X
Surface water biological quality (<i>i.e.</i> , microbiology)		4, 5	A, B, C, I		11	A, B, C, U		19	A, B, C, X
Surface water chemical quality (<i>i.e.</i> , general chemistry and trace metals)		5, 6	A, B, C, I		13 to 15	A, B, U, V		19	A, B, C, X
Surface water quantity (<i>i.e.</i> , runoff volume, drainage patterns, and discharges)		7, 8	A to F, J		16, 17	A, B, C		19	A, B, C, X
Contamination by hydrocarbons / hazardous chemicals		9, 10	A, B, C, K to T		18	A, B, C, I, L, M, W		19	A, B, C, X

PATHWAYS

- 1 – Construction activities, especially those activities that occur in the presence of exposed soils and / or within 30 m of the Saint John River, have the potential to increase the amount of sediment entering the River, which can increase turbidity / suspended sediment concentrations.
- 2 – Clearing and levelling the site may alter overland flow conditions across the Project site (*i.e.*, timing, duration, frequency, and volume) due to changes in slope, removal of vegetation, ditching, *etc.*, may cause water to be quickly dispersed from the site, and conditions may become “flashy”.
- 3 – Runoff from stockpiles may contain increased sediment loads that are subsequently transported to the Saint John River.
- 4 – Vegetation clearing and landscaping will lead to altered surface conditions that may affect the pathogens / bacteria (*i.e.*, total coliforms and *Escherichia coli*) that are introduced to the Saint John River from the Project site.
- 5 – Leaks or spills on the ground during use or maintenance of temporary construction personnel sanitary facilities may cause untreated sanitary waste to be introduced to the Saint John River.
- 6 – Clearing vegetation may affect the quality of water being introduced to the Saint John River from the Project site, such as nutrient levels, dissolved oxygen levels, temperature, woody debris, and sediment concentrations.
- 7 – Exposure of rock and sediment during Project construction may alter the quality of surface water flowing from the Project site.
- 8 – Foundations and asphalt roadways / parking areas create impermeable surfaces, which may alter overland flow conditions across the Project site (*i.e.*, timing, duration, frequency, and volume).
- 9 – There is a potential that hydrocarbons, through their storage and use onsite, could be introduced to the Saint John River.
- 10 – There is a potential that hazardous chemicals, through their storage and use onsite, could be introduced to the Saint John River.
- 11 – The environmental treatment facility will yield significant decreases of BOD₅, TSS, and COD_{TOTAL} in the effluent discharged to the Saint John River.
- 12 – Extracting brackish water from the Saint John River, using it to cool process water through a non-contact loop within the Mill, and returning it warmer to the Saint John River is expected to have little impact on the thermal regime of Mill Cove (*i.e.*, ~ 0.03 °C). There will be an overall reduction in warm water discharged to the Saint John River because of the overall reduced effluent flow.
- 13 – Three-dimensional hydrodynamic plume modelling completed by the Ocean, Coastal, and River Engineering Research Centre of the National Research Council indicate that mixing processes, which are driven by the highly turbulent ambient flow conditions at Reversing Falls, dominate the behaviour and dilution of the effluent from the Main Mill Outfall.
- 14 – Surface and near-bed modelling suggest that the effluent plume from the Main Mill Outfall extends further under existing conditions compared to when the environmental treatment facility and water use reduction project is in operation and is largely a result of a decrease in effluent discharge.
- 15 – Modelling suggests that effluent concentrations reduce to < 1 % within 300 m and 200 m from the Main Mill Outfall at the surface and near the bed of the Saint John River.
- 16 – Once the Project is in operation, raw industrial freshwater drawn from the Spruce Lake Watershed and subsequently discharged to the brackish Saint John River will reduce by up to 50 %, which reduces the volume of water transferred from one watershed to another.
- 17 – Reducing the raw industrial freshwater drawn from the Spruce Lake Watershed may yield other benefits, such as increased water levels within the Spruce Lake Watershed during periods of low flow / drought sometimes experienced during the summer. This may yield indirect benefits, such as improved water levels for recreational users of the various waterways within the Watershed.
- 18 – Not only will the Project provide additional treatment yielding a higher quality effluent, but a diversion basin will be incorporated to allow operators to divert effluent in the event of an extreme upset event (*i.e.*, the tank will provide for spill diversion and surge protection).
- 19 – If a major mishap, error and / or unforeseen event were to occur at the site (*e.g.*, a treatment tank ruptures, a valve fails during the transfer of effluent to the diversion tank during an upset event, *etc.*), there is a possibility that the Saint John River could be impacted.

MITIGATION

- A – A Project-specific environmental protection plan will be developed to provide best-management practices that all Project personnel should follow in order to limit the potential for impacts to the surface water environment.
- B – All Project personnel should be briefed on the potential impacts the Project may have on surface water quality and quantity; this could range from explaining that soil erosion may increase due to vegetation removal, to possible contamination by hydrocarbons due to spills.
- C – Mitigation measures developed for this Project should be adhered to in order to adequately address potential impacts on surface water quantity and quality.
- D – An erosion and sedimentation control plan, which may form part of the Project-specific environmental protection plan, should be developed and implemented prior to completing any onsite works and may include the installation and management of structures, such as strawbale barriers, rock check dams, silt fences, *etc.*, to limit and control erosion and sedimentation.
- E – Erosion and sediment control structures should be regularly inspected and maintained according to the Project-specific environmental protection plan to ensure they continue to protect against erosion and sedimentation.
- F – A surface water drainage management plan, which may form part of the Project-specific environmental protection plan, should be developed and implemented prior to completing any onsite works and may include the use of ditches and settling basins to control surface water flow and to reduce sediment concentrations in water prior to discharge from the site.
- G – Material stockpiles should be located at least 30 m from the Saint John River.
- H – Material stockpiles should not be located in areas where there is a concentration of surface water runoff. Perimeter erosion control, such as silt fencing, should be erected around material stockpiles to protect them from surface water runoff.
- I – During construction activities, all sanitary waste associated with those construction activities should be collected using self-contained portable washroom

facilities and those wastes should be handled and disposed of by a licensed waste disposal operator.

J – Trenching and ditching may be required at the base of any large rock faces that are created in order to collect and direct any groundwater discharge from the rock faces.

K – All heavy equipment used onsite should be in good repair and free of excess oil and grease, the equipment should be equipped with appropriately-sized spill response equipment (*i.e.*, spill kits), all Project personnel will be trained in the use of such equipment, and the equipment should be regularly maintained and inspected to minimize the risk of hydrocarbon-based fluid spills that may pose a threat to the Saint John River.

L – Concrete slurry wastes should not be allowed to spill on to the ground and concrete equipment should only be washed up in designated areas where concrete wastes can set, be broken up, and subsequently disposed of appropriately. To do this, temporary concrete washout facilities should be constructed using an impermeable liner and designed and maintained in sufficient quantity and size to contain all liquid and concrete waste generated by onsite washout operations.

M – Construction debris, surplus materials, and other solid waste materials should not be disposed of onsite (*n.b.*, this does not apply to excavated soils and rock) and waste receptacles / bins should be made available for containing construction debris and other solid waste materials for temporary storage before offsite disposal at an approved facility.

N – Road sweeping units should be equipped with sediment collection hoppers to limit the spread of contaminants that could possibly be entrained in surface water runoff and be subsequently introduced to the Saint John River. Should dust suppression be required, the preferred method of control is by applying water.

O – Sand should be used for winter roadway maintenance instead of salt because the majority of sand can be collected through roadway sweeping whereas salt dissolves in water and can be more easily introduced to the Saint John River.

P – Vehicle speeds on the site should be limited to that necessary to limit the generation of dusts.

Q – Designated refueling locations should be identified within the Project-specific environmental protection plan (*e.g.*, > 30 m from the edge of watercourse, *etc.*) and those locations should be equipped with appropriately stocked and maintained spill response equipment (*i.e.*, spill kits). Refueling should only be done by trained and competent personnel using a means of spill containment, such as completing the operation atop an impermeable liner or using spill collection pans. Any materials used to clean-up spills, contaminated materials, and recovered spilled material that is not suitable for reuse should be stored and disposed of appropriately.

R – All potential contaminants and contaminated materials will be stored in a contained area where they cannot become mobilized or access the ground surface (*i.e.*, be placed atop and within spill containment pads).

S – Regular maintenance and inspection of equipment onsite should be performed to minimize the risk of spills of oil based fluids that pose a threat to the Saint John River.

T – All spills of hazardous materials should be reported immediately to the appropriate Regulator(s).

U – Throughout operations, monitoring of effluent quality should be undertaken by IPP personnel and / or accredited third-party laboratories to assess quality of the treated effluent and compliance with regulations.

V – Water quality sampling, which is focused on the final effluent discharge from the Main Mill Outfall, should be conducted once the Project is in operation to validate that the effluent data input to the three-dimensional hydrodynamic plume model was appropriate or needs to be adjusted.

W – Operators should ensure that if an upset event occurs, effluent is directed to the diversion tank until the effluent can be treated appropriately.

X – Emergency response / contingency plans should be designed to prevent any major and / or sustained environmental damage during any errors, mishaps, and / or unforeseen events.

Table 52. Assessment of potential impacts on groundwater quantity and quality of the proposed environmental treatment facility and water use reduction project at the Reversing Falls Mill in Saint John, New Brunswick.

Potential Impact	Stage II: Construction			Stage III: Operation and Maintenance			Stage V: Mishaps, Errors, and / or Unforeseen Events		
	Degree of Impact	Pathways	Mitigation	Degree of Impact	Pathways	Mitigation	Degree of Impact	Pathways	Mitigation
Groundwater quality		1	A to F		8	A, B, C		10	A, B, C, G
Groundwater quantity		1	A to F		8	A, B, C			
Hydrocarbon / hazardous chemical contamination		1, 2, 3	A, B, C, G to S		1, 4, 5, 9	A, B, C, G, K to N, Q to S		10	A, B, C, G, K to N, Q to S
Groundwater recharge areas		4	A, C						
Groundwater discharge areas									

PATHWAYS

- 1 – Surrounding properties served by individual onsite groundwater wells for potable water are located upgradient. Therefore, no impact is anticipated.
- 2 – Spills can occur during refueling operations, while operating and maintaining heavy equipment, or during the storage of such products. The potential impacts from a hydrocarbon / hazardous chemical spill would be dictated by the size, duration and location of the spill.
- 3 – Some properties in the surrounding area are served by individual onsite groundwater wells for potable water. If a hydrocarbon or hazardous chemical spill migrates to the groundwater system, the potential impacts could be long lasting because groundwater systems are complex and often difficult to remediate once contaminated.
- 4 – Further developing the lands and installing impermeable surfaces, such as concrete and asphalt, will reduce the amount of greenspace available for groundwater recharge.
- 5 – Once the Project is operational there will be little additional impact to the groundwater environment.
- 6 – During operation and maintenance, there will be minimal use of hydrocarbon / hazardous chemicals on the site; however, there is a potential for spills, including effluent, to occur.
- 7 – If the mishap, error, and / or unforeseen event is significant, there is a potential for the damage to be severe and / or irreversible.

MITIGATION

- A – A Project-specific environmental protection plan will be developed to provide best-management practices that all Project personnel should follow in order to limit the potential for impacts to the groundwater environment to occur.
- B – All Project personnel should be briefed on the potential impacts that the Project could have on ground water quality.
- C – Mitigation measures developed for this Project should be adhered to in order to adequately address potential impacts on groundwater quantity and quality.
- D – An erosion and sedimentation control plan, which may form part of the Project-specific environmental protection plan, will be developed and implemented prior to completing any onsite works and may include the installation and management of structures, such as strawbale barriers, rock check dams, silt fences, *etc.*, to limit and control erosion and sedimentation.
- E – Erosion and sediment control structures will be regularly inspected and maintained according to the Project-specific environmental protection plan to ensure they continue to protect against erosion and sedimentation.
- F – A surface water drainage management plan, which may form part of the Project-specific environmental protection plan, will be developed and implemented prior to completing any onsite works and may include the use of ditches and settling basins to control surface water flow and to reduce sediment concentrations in water prior to discharge from the site.
- G – All heavy equipment used onsite should be in good repair and free of excess oil and grease, the equipment should be equipped with appropriately-sized spill response equipment (*i.e.*, spill kits) and all Project personnel will be trained in the use of such equipment, and the equipment should be regularly maintained and inspected to minimize the risk of hydrocarbon-based fluid spills that may pose a threat to groundwater systems.
- H – Concrete slurry wastes should not be allowed to spill on to the ground and concrete equipment should only be washed up in designated areas where concrete wastes can set, be broken up, and subsequently disposed of appropriately. To do this, temporary concrete washout facilities should be constructed using an impermeable liner and designed and maintained in sufficient quantity and size to contain all liquid and concrete waste generated by onsite washout operations.
- I – Construction debris, surplus materials, and other solid waste materials should not be disposed of onsite (*n.b.*, this does not apply to excavated soils and rock) and waste receptacles / bins should be made available for containing construction debris and other solid waste materials for temporary storage before offsite disposal at an approved facility.
- J – Material stockpiles should not be located in areas where there is a concentration of surface water runoff and perimeter erosion control, such as silt fencing, should be erected around material stockpiles to protect them from surface water runoff.
- K – Road sweeping units should be equipped with sediment collection hoppers to limit the spread of contaminants that could possibly be entrained in surface water runoff and be subsequently introduced to groundwater systems. Should dust suppression be required, the preferred method of control is by applying water.
- L – Sand should be used for winter roadway maintenance instead of salt because the majority of sand can be collected through roadway sweeping whereas salt dissolves in water and can be more easily introduced to groundwater systems.
- M – Vehicle speeds on the site should be limited to that necessary to limit the generation of dusts.
- N – Connection to alternative water supplies, such as a municipal distribution system, is most often required when an aquifer is contaminated.
- O – During construction activities, all sanitary waste associated with those construction activities should be collected using self-contained portable washroom facilities and those wastes should be handled and disposed of by a licensed waste disposal operator.
- P – Designated refueling locations should be identified within the Project-specific environmental protection plan (*e.g.*, > 30 m from the edge of watercourse, *etc.*) and those locations should be equipped with appropriately stocked and maintained spill response equipment (*i.e.*, spill kits). Refueling should only be done by trained and competent personnel using a means of spill containment, such as completing the operation atop an impermeable liner or using spill collection pans. Any materials used to clean-up spills, contaminated materials, and recovered spilled material that is not suitable for reuse should be stored and disposed of appropriately.
- Q – All potential contaminants and contaminated materials will be stored in a contained area where they cannot become mobilized or access the ground surface (*i.e.*, be placed atop and within spill containment pads).
- R – Regular maintenance and inspection of equipment onsite should be performed to minimize the risk of spills of oil based fluids that pose a threat to groundwater systems.
- S – All spills of hazardous materials should be reported immediately to the appropriate Regulator(s).

4.4.3 Biological Environment

4.4.3.1 Terrestrial Flora and Fauna

Human's lives are maintained and enhanced by interactions between flora and fauna. To demonstrate this, three national surveys (*i.e.*, 1981, 1987, and 1991) were conducted to probe Canadians on the socioeconomic importance of wildlife. Through those surveys [Gray *et al.*, 1993], it was determined that wildlife plays an important role in the lives of about 90 % of Canadians whether it be feeding, observing, photographing, hunting, trapping, *etc.* [Filion *et al.*, 1987].

As detailed in Section 3.2.4, the Project site is almost devoid of vegetation and there are no virgin lands involved as detailed in Section 3.3.5. Fauna living in adjacent areas may migrate through the area on occasion.

4.4.3.1.1 Conceivable Impacts and Pathways

The potential impacts on terrestrial flora and fauna and their associated pathways during the Project are summarized in Table 53. In the section that follows, the potential impacts are assessed in concert with the development of mitigation measures.

Table 53. The type of cause-effect relationships that are possible and the mechanisms by which stressors could ultimately lead to impacts on terrestrial flora and fauna during various activities associated with the proposed environmental treatment facility and water use reduction project at the Reversing Falls Mill in Saint John, New Brunswick.

Activity	Conceivable Impacts and Pathways
Vegetation clearing, grubbing, stripping, grading, and site development	<ul style="list-style-type: none"> ➤ Topsoil removal could result in the loss of the native plant seed bank, nutrients, organic matter, and microorganisms that are essential for plant growth ➤ Loss of vegetation may result in a loss of habitat for wildlife ➤ Loss of vegetation could result in the loss of a species of special concern ➤ Loss of vegetation could lead to habitat fragmentation ➤ Loss of vegetation may eliminate wildlife corridors and / or alter wildlife movements (<i>i.e.</i>, habitat connectivity) ➤ Loss of vegetation and replacement with an industrial facility may affect local biodiversity ➤ Altered overland flow conditions (<i>i.e.</i>, timing, duration, frequency, and volume) may affect water available for use by vegetation (<i>i.e.</i>, reduced infiltration) ➤ Increased overland flow may reduce the amount of water available, captured, and stored for vegetation ➤ Injury or death of invertebrates, amphibians, reptiles, small mammals, and vegetation ➤ Potential to introduce or spread invasive species
Rock breaking and excavating with pneumatic hammers	<ul style="list-style-type: none"> ➤ Loud intermittent sounds and vibrations may scare away wildlife ➤ Loud intermittent sounds and vibrations could cause stress to wildlife
Operation and maintenance of heavy equipment	<ul style="list-style-type: none"> ➤ Sound emitted from heavy equipment could scare away / displace wildlife ➤ Sounds emitted from heavy equipment could make the hunting process by predators more difficult (<i>i.e.</i>, prey may be more easily startled) ➤ Sounds emitted from heavy equipment could interfere with the audible communication of wildlife (<i>e.g.</i>, bird mating calls, <i>etc.</i>)

Activity	Conceivable Impacts and Pathways
	<ul style="list-style-type: none"> ➤ Ground spills of hydrocarbons during refueling operations (<i>i.e.</i>, gasoline and diesel) may contaminate food and water sources for wildlife ➤ Leaks of hydraulic fluids, oils, <i>etc.</i> during normal operations may spill on to the ground and contaminate food and water sources for wildlife ➤ Exhaust from heavy equipment can lead to the surface contamination of vegetation (<i>i.e.</i>, via particulate matter), which can be absorbed by plants that are later consumed by wildlife ➤ Emission particulates, and specifically those containing heavy metals, can be ingested by wildlife that can then bioaccumulate and biomagnify up the food chain ➤ Emission particulates can lead to the acidification of soils and cause death or injury to vegetation ➤ Sound emitted from equipment could disturb wildlife interactions, feeding, and breeding ➤ Potential for wildlife collisions ➤ Tall equipment (<i>i.e.</i>, cranes) could lead to collisions with birds particularly during low-visibility conditions
Temporary construction personnel sanitary facilities	<ul style="list-style-type: none"> ➤ Leaks or spills on the ground during use or maintenance may contaminate food and water sources for wildlife
Storage and handling of various hazardous chemicals	<ul style="list-style-type: none"> ➤ Leaks or spills on the ground during the handling and storage of hazardous chemicals (<i>e.g.</i>, hydrocarbons, paints, solvents, polymers, acids, <i>etc.</i>) may contaminate food and water sources for wildlife
Dust suppression and winter roadway clearing	<ul style="list-style-type: none"> ➤ Dusts emitted from the Project site (<i>e.g.</i>, vehicle traffic on roadways, wind erosion of aggregate stockpiles, <i>etc.</i>) may land on vegetation and affect primary production (<i>i.e.</i>, by impacting photosynthesis, respiration, and transpiration and allowing the penetration of phytotoxic gaseous pollutants) ➤ If chemical dust suppressants are used on roadways, they may be entrained in overland flow and subsequently transported to surface water sources used by wildlife ➤ If salt is used for winter roadway maintenance, it may be entrained in overland flow and be subsequently transported to and contaminate surface water sources used by wildlife
Temporary storage of hazardous waste	<ul style="list-style-type: none"> ➤ If construction and hazardous waste that is temporarily stored onsite prior to safe disposal is not properly stored, wildlife may get in to it and be injured and / or poisoned
Temporary storage of food wastes	<ul style="list-style-type: none"> ➤ If refuse from Project personnel is not properly stored, it may be an attraction for wildlife, which could result in unwanted interactions between humans and wildlife
Safety lighting	<ul style="list-style-type: none"> ➤ Light emitted from operational employee safety lights may attract birds, which could lead to collisions with onsite infrastructure resulting in injury or mortality

Based on information obtained from the ACCDC, some COSEWIC and SARA ranked species of terrestrial fauna do exist within a 5 km radial buffer surrounding the Project site (*i.e.*, refer to Section 3.2 for a description of the species, Appendix VIII for the ACCDC data report, and Table 27 for a listing and Figure 55, Figure 61, Figure 62, and Figure 63 for distribution maps). The following potential impacts were evaluated with respect to terrestrial flora and fauna:

- species of concern (*i.e.*, SARA and COSEWIC listed species);
- flora and habitat;
- flora associations and biodiversity;

- fauna (*i.e.*, birds, animals, and mammals) and habitat (direct and indirect);
- fauna and habitat fragmentation; and
- fauna migration patterns (*i.e.*, migratory birds), nesting, and food chains.

4.4.3.1.2 Potential Impacts

The Project site does not contain any substantial areas that are vegetated with terrestrial flora. Because the site is almost completely devoid of vegetation, there is little to no habitat that would be desirable for terrestrial fauna. None of those species identified in the ACCDC report are known to inhabit the property. Furthermore, the probability for any of those species being impacted by the proposed Project is extremely low given the existing and long-lived land-use as a heavy industrial site (*i.e.*, refer to Section 3.3.5).

Migratory birds are afforded special protection under the *Migratory Birds Convention Act [S.C., 1994, c. 22]*. Several species of migratory birds are known to migrate through the Saint John region (*e.g.*, Canada geese, semipalmated sandpipers, *etc.*). The lack of vegetation and cover on the site makes it an unlikely area for nesting locations. The presence and continuous movement of heavy equipment on the site (*e.g.*, transport trucks, loaders, bulldozers, *etc.*) and the lack of suitable habitat makes it unattractive for staging and stopover areas. Nearby nesting grounds and open waters used by migratory birds are also unlikely to be indirectly affected by the Project. Although several sightings of ACCDC ranked migratory birds have been observed within a 5 km radial buffer around the site, none of those species are known to inhabit or frequent the site (*n.b.*, they may be transient visitors).

The impact assessment for terrestrial flora and fauna is summarized in Table 55. Because of existing conditions as a heavy industrial site with a well-prepared and implemented EMS by IPP personnel, there is expected to be very little change between now and throughout the various Project stages. As a result, no change lights were applied to the majority of potential impacts ($n = 9$). Green lights were given to two potential impacts during operation and maintenance. Yellow lights were applied to the remaining seven potential impacts and are primarily related to species of special conservation concern (*i.e.*, should they migrate through the area), which are susceptible to environmental impacts.

4.4.3.1.3 Proposed Mitigation

The mitigation measures listed below should be employed to minimize the probability of activities related to the Project from affecting terrestrial flora and fauna surrounding the Mill site.

- A Project-specific environmental protection plan will be developed to provide best-management practices that all Project personnel should follow in order to limit the potential for impacts to terrestrial flora and fauna to occur. {Applicable to Stages II, III, and V}
- All Project personnel should be briefed on the potential impacts the Project may have on terrestrial flora and fauna. {II, III, and V}
- Mitigation measures developed and included in the Project-specific environmental protection plan should be adhered to in order to adequately address potential impacts. {II, III, and V}

- A perimeter fence should be erected at the boundary of the Project site to keep the majority of land-based wildlife from accessing the site. {II, III, and V}
- Extremely loud, intrusive, or otherwise potentially harassing activities (e.g., pile driving, etc.) should be avoided or limited during periods of the year when wildlife are under severe environmental and physiological stress, such as the spring breeding season for birds. {II, III, and V}
- Any sensitive flora should be salvaged and relocated from the Project site. {II}
- Any vegetation clearing activity should be undertaken outside of the migration and breeding season for migratory birds (i.e., 5 April through 31 August in the Greater Saint John region). {II}
- If species listed under the federal *Species At Risk Act* [S.C. 2002, c. 29] are observed on the Project site, then their sightings will be reported to Environment and Climate Change Canada's Canadian Wildlife Service branch and if a species listed under the provincial *Species At Risk Act* [R.S.N.B. 2012, c 6] are observed on the Project site, then their sightings will be reported to the New Brunswick Department of Natural Resources and Energy Development. {II, III, and V}
- Equipment should arrive at the Project site in a clean condition free of invasive and noxious weeds. {II}
- All Project personnel should report all unusual wildlife encounters to the Project supervisor during construction and to the Environmental Manager during operation. {II, III, and V}
- Project personnel should properly dispose of food scraps and garbage in the appropriate onsite receptacles, such as "predator-proof" garbage bins provided by the contractor or proponent. {II, III, and V}
- Waste stored onsite should be stowed in an appropriate manner and be transported to an appropriate disposal facility (e.g., Crane Mountain Landfill, etc.) on a regular basis. {II, III, and V}
- Project personnel should be advised, prior to working on the Project site, to not feed or harass nuisance wildlife (e.g., varmint, pigeons, sea gulls, rodents, etc.). {II, III, and V}
- Heavy equipment and other vehicles used on the Project site should yield the right-of-way to wildlife. {II, III, and V}
- No attempt should be made to chase, catch, divert, follow, or otherwise harass any wildlife by vehicle or on foot. {II, III, and V}
- If injured or deceased wildlife are encountered, then representatives with the New Brunswick Department of Natural Resources and Energy Development and Canadian Wildlife Service should be contacted to determine the appropriate course of action. {II, III, and V}
- If deceased animals are encountered, they should be removed and disposed of as soon as possible in consultation with representatives of the New Brunswick Department of Natural Resources and Energy Development and Canadian Wildlife Service. {II, III, and V}
- No Project personnel should affect wildlife populations by either hunting or trapping and firearms should be strictly prohibited on the Project site. {II, III, and V}
- If an active nest, den, etc. is encountered, a no-disturbance buffer zone of 30 m+ should be established around the area (n.b., flagging tape should not be used to mark the feature as it increases the chance of predation and representatives with

the Canadian Wildlife Service should be contacted to determine the appropriate buffer size) until a qualified biologist determines if the buffer zone shall remain, if the size should be increased, or if the buffer zone can be eliminated (*i.e.*, the animal has abandoned the feature). {II, III, and V}

- No Project personnel should deposit or permit to be deposited oil, oil wastes, or any other substance harmful to wildlife in any waters or any area frequented by wildlife. {II, III, and V}
- An oil spill prevention and response plan should be developed as part of the Project-specific environmental protection plan. {II, III, and V}
- Emergency response and contingency plans should be designed to prevent any sustained environmental damage during any mishaps, errors, and / or unforeseen events. {II, III, and V}

4.4.3.1.4 Potential Post-Mitigation Residual Impacts

No residual effects are likely to occur to terrestrial flora and fauna over the duration of the Project assuming the above mitigation measures are implemented.

4.4.3.2 Aquatic Flora and Fauna

The Mill is located adjacent to Reversing Falls on the Saint John River and there is a long history of connection between the Mill and the River. As noted in Section 3.3.5, a Mill has existed at the site since at least 1836.

The Saint John River supports many communities ecologically and socially along its route from headwaters to mouth. It provides habitat for numerous species and is a source of water for many purposes, such as hydroelectricity, potable water, process water, and irrigation water and a sink for many sources, such as agricultural and urban runoff, and municipal and industrial effluents. It is also used for many transportation and recreational purposes throughout the year. The River has and continues to be affected by anthropogenic activities.

4.4.3.2.1 Conceivable Impacts and Pathways

The potential impacts on aquatic flora and fauna and their associated pathways during the Project are summarized in Table 54. In the section that follows, the potential impacts are assessed in concert with the development of mitigation measures.

Table 54. The type of cause-effect relationships that are possible and the mechanisms by which stressors could ultimately lead to impacts on aquatic flora and fauna during various activities associated with the proposed environmental treatment facility and water use reduction project at the Reversing Falls Mill in Saint John, New Brunswick.

Activity	Conceivable Impacts and Pathways
Vegetation clearing, grubbing, stripping, grading, and site development	<ul style="list-style-type: none"> ➤ Increased erosion potential and exposed sediments may be entrained in overland flow and transported to watercourses, wetlands, and / or the Bay of Fundy where entrained sediments (<i>i.e.</i>, elevated levels of total suspended sediments) may affect the water quality ➤ Excessive amounts of sediment introduced to surface water systems can affect light penetration and could affect growth of aquatic vegetation

Activity	Conceivable Impacts and Pathways
	<ul style="list-style-type: none"> ➤ Excessive amounts of sediment introduced to surface water systems can smother and displace aquatic fauna (<i>e.g.</i>, benthic invertebrates) ➤ Altered overland flow conditions (<i>i.e.</i>, timing, duration, frequency, and volume) due to changes in slope, removal of vegetation, ditching, <i>etc.</i> may cause water to be quickly dispersed from the site; conditions may become “flashy” ➤ Amount of water directed to the subsurface may be reduced, which could cause changes to baseflow in watercourses ➤ Loss of vegetation may affect soil stability, which may lead to increased erosion potential ➤ Runoff from stockpiled spoils may contain increased sediment loads that are subsequently transported to surface water systems ➤ Loss of vegetation may affect nutrient loading (<i>e.g.</i>, nitrogen and phosphorous) and chemical species (<i>i.e.</i>, changing the water chemistry) being introduced to surface water systems ➤ Loss of vegetation, and in particular streamside vegetation, may alter aquatic habitats, such as reducing the amount of woody debris input (<i>i.e.</i>, used by fish and invertebrates as refuge from predators) ➤ Loss of vegetation can affect the thermal regime of water habitats (<i>i.e.</i>, loss of forest canopy used as stream shade and loss of forest canopy can alter the thermal regime of shallow groundwater feeding surface waters) ➤ Development of debris dams can affect movements of fauna or flood out emergent vegetation ➤ Sediment and other deleterious substances can affect the olfactory navigation used by some fish species during migration ➤ Use of fertilizers could allow contaminants to be introduced to surface water systems and / or connected groundwater systems
Rock breaking and excavating with pneumatic hammers and pile driving	<ul style="list-style-type: none"> ➤ Shock waves and vibrations could have lethal (<i>i.e.</i>, damage to the swim bladder of fishes or rupture of internal organs) or sub-lethal (<i>e.g.</i>, behavioural) effects on aquatic fauna (<i>i.e.</i>, avoidance of preferred habitat, changes to migration, reduced feeding, and / or reduced schooling that could increase predation) ➤ Sound can affect reptiles and amphibians by forcing them from their habitat or causing undue stress ➤ Surface materials may be loosened, which may lead to increased erosion potential
Operation and maintenance of heavy equipment	<ul style="list-style-type: none"> ➤ Vibrations from heavy equipment could have lethal (<i>i.e.</i>, damage to the swim bladder or rupture of internal organs) or sub-lethal (<i>e.g.</i>, behavioural) effects on fish ➤ Use of mobile industrial equipment may lead to the re-suspension and entrainment of sediments in watercourses and / or wetlands ➤ Ground spills of hydrocarbons during refueling operations (<i>i.e.</i>, gasoline and diesel) may allow hydrocarbons to be introduced to surface water systems and cause contamination with lethal or sub-lethal results ➤ Leaks of hydraulic fluids, oils, <i>etc.</i> during normal operations may spill on to the ground and be introduced to surface water systems and cause contamination with lethal or sub-lethal results ➤ Exhaust from heavy equipment can lead to the surface contamination of aquatic vegetation (<i>i.e.</i>, via particulate matter), which can be absorbed and either cause damage or death ➤ Emission particulates, and specifically those containing heavy metals, can be ingested by fauna that can bioaccumulate and biomagnify up the food chain (<i>e.g.</i>, mercury is a particular heavy metal that is often a problem in aquatic ecosystems)
Temporary construction	<ul style="list-style-type: none"> ➤ Leaks or spills on the ground during use or maintenance may cause untreated

Activity	Conceivable Impacts and Pathways
personnel sanitary facilities	sanitary waste to be introduced to surface water systems and results can be lethal or sub-lethal to aquatic flora and fauna
Storage and handling of various hazardous chemicals	<ul style="list-style-type: none"> ➤ Leaks or spills on the ground during the handling and storage of hazardous chemicals (<i>e.g.</i>, paint, epoxies, concrete additives, cleaners, solvents, <i>etc.</i>) may cause surface water and / or groundwater contamination with lethal or sub-lethal results on aquatic flora and fauna
Footing and foundation construction and roadway paving	<ul style="list-style-type: none"> ➤ Dewatering activities may cause sediment to be entrained in discharged water that could be subsequently transported to surface waters and / or groundwater
Dust suppression and winter roadway clearing	<ul style="list-style-type: none"> ➤ Dusts emitted from the Project site (<i>e.g.</i>, vehicle traffic on roadways, wind erosion of aggregate stockpiles, <i>etc.</i>) may land on aquatic vegetation and affect primary production (<i>i.e.</i>, by impacting photosynthesis, respiration, and transpiration and allowing the penetration of phytotoxic gaseous pollutants) ➤ Excessive amounts of dust introduced to surface water systems can affect light penetration and could affect growth of aquatic vegetation ➤ If chemical dust suppressants are used on roadways, they may be entrained in overland flow and subsequently transported to and contaminate surface waters and / or groundwater ➤ If salt is used for winter roadway maintenance, it may be entrained in overland flow and subsequently transported to and contaminate surface waters and / or groundwater
Temporary storage of construction and hazardous waste	<ul style="list-style-type: none"> ➤ Precipitation may come in contact with construction and hazardous waste that is temporarily stored onsite prior to safe disposal, which may cause water to become contaminated and subsequently infiltrate to the aquifer
Cooling water intake	<ul style="list-style-type: none"> ➤ Drawing water in to the system may lead to fish impingement or entrainment

The Project site is adjacent to the Saint John River. Watercourses adjacent to the Project site, and the flora and fauna occupying them, may be negatively impacted by the Project in several ways: 1) via the release of contaminants, such as hydrocarbons from refueling activities and heavy equipment breakdown / malfunction; 2) the release of sediments during surface water runoff; and 3) the intake of brackish water for cooling water. Therefore, there is potential for the Project to have a negative impact on the aquatic flora and fauna contained within the Saint John River, which the ACCDC identifies as containing some aquatic fauna that are protected under the pSARA or the COSEWIC (*e.g.*, the American eel and striped bass; refer to Appendix VIII for the ACCDC report). The discharge of warmed brackish water and the discharge of treated effluent to the Saint John River were assessed under the surface water quantity and quality VEC (*i.e.*, refer to Section 4.4.2.3). Because the assessment under that VEC showed little impact, it is not believed they will have any considerable impact on the wider aquatic flora and fauna communities.

Based on the conceivable impacts and pathways identified in Table 54, the following specific potential impacts were assessed for aquatic flora and fauna:

- species of concern (*i.e.*, SARA and COSEWIC listed);
- flora and habitat;
- flora associations and biodiversity;
- fauna (*e.g.*, fishes, mammals, *etc.*) and habitat (*i.e.*, direct and indirect);

- fauna habitat fragmentation;
- fauna migration patterns (*i.e.*, anadromous fishes) / food chains; and
- fish impingement and entrainment.

4.4.3.2.2 Potential Impacts

The impact assessment for aquatic flora and fauna is summarized in Table 56. There is not likely to be any significant change between now, through Project construction, and when the Project is in operation. Therefore, the majority of the potential impacts assessed were given no change lights ($n = 10$) or green lights ($n = 6$). Five yellow lights were applied to potential fish impingement and entrainment related to the cooling water intake and potential unforeseen mishaps, errors, and / or unforeseen events.

As per Section 30 of the *Fisheries Act* [R.S.C., 1985, c. F-14], fish screening must be provided on water intake structures within any waters frequented by fish. To protect fish from impingement or entrainment, the approach velocity (*i.e.*, the water velocity into, or perpendicular to, the face of a water intake screen) should not exceed certain values based on the swimming mode (*i.e.*, subcarangiform or anguilliform) of the fish present in the watercourse. The Saint John River contains subcarangiform (*e.g.*, salmonids, sturgeon, striped bass, *etc.*) and anguilliform (*e.g.*, eels, lamprey, *etc.*) swimming species.

The Department of Fisheries and Oceans (DFO) has prepared guidelines for fish screening on the end of freshwater intake pipes [DFO, 1995]. Those guidelines provide protection of freshwater fish with a minimum fork length of 25 mm. The guidelines are for small-scale water intakes (*e.g.*, irrigation, construction, municipal and private water supplies, mining exploration, *etc.*) where flow rates are $\leq 0.15 \text{ m}^3 \cdot \text{s}^{-1}$. Under the guidelines, the maximum intake velocity for small freshwater intakes should be $\leq 0.15 \text{ m} \cdot \text{s}^{-1}$. Fedorenko [1991], developed guidelines for the siting and design of large-scale water intakes within marine waters of British Columbia. Maximum intake velocity for those structures was pegged at $\leq 0.12 \text{ m} \cdot \text{s}^{-1}$. There are no Canadian guidelines relevant to water intakes located within estuarial waters, such as that proposed for the Project.

As shown through modelling by the NRC, the waters of Mill Cove have a strong circulation pattern. A rotational eddy in the cove flows clockwise during ebb tide and counter-clockwise during flood tide. The majority of the time (*i.e.*, outside of slack tides), current speeds within Mill Cove exceed $0.4 \text{ m} \cdot \text{s}^{-1}$. The currents are driven by the dynamic exchange of freshwater from upstream and seawater from the Bay of Fundy.

The dimensions of the Project's cooling water passive intakes (*i.e.*, refer to Section 2.7.2.1) will be determined during detailed engineering design; however, the vendor (*i.e.*, Johnson Screens) designs their passive intake screens based on their clients' requirements. For this Project, the maximum intake velocity will be $0.15 \text{ m} \cdot \text{s}^{-1}$ and the maximum screen size will be 2.54 mm. Data collected by the USEPA shows that 96 % of studied fish can avoid an intake structure when the intake velocity is $\leq 0.15 \text{ m} \cdot \text{s}^{-1}$ [USEPA, 2014]. The intake screen vendor has considerable experience using these design criteria as they are compliant with the USEPA's *Clean Water Act* [33 U.S.C. § 1251 et seq. 1972] Section 316(b) with respect to fish and shellfish impingement and entrainment (*n.b.*, refer to Appendix V for additional information on the high-capacity, low velocity intake screens). The air-backwash-system included with the intakes will mitigate any impinged material on the screen. For this reason, it is expected that the cooling water intake of the Project will

have negligible impact of fish impingement and entrainment; however, the assessment yielded yellow lights (Table 56).

Coutant [2021] assessed the type of high-capacity, low-velocity passive intake screen proposed for this Project and fish entrainment within the Columbia River near Richland, Washington. Although the screens have not yet been designed for IPP, they will be somewhat similar in overall dimensions to that described by *Coutant* [2021] as the volume extractions between the two systems are similar (*n.b.*, the Columbia River intake studied is at the Columbia Generating Station, an electricity generating station). For the Columbia River screen, the maximum through-screen velocity is $\sim 0.2 \text{ m} \cdot \text{s}^{-1}$, which yields an approach velocity of $0.03 \text{ m} \cdot \text{s}^{-1}$. For this Project, the through-screen velocity be $< 0.15 \text{ m} \cdot \text{s}^{-1}$, which should yield an even lower approach velocity (*n.b.*, the velocities are modelled based on the screen dimensions so the approach velocity for IPP will not be known until detailed design).

The Swim Performance Online Tools program (<http://fishprotectiontools.ca/>) was used to estimate the maximum approach velocity for species potentially present within Mill Cove. Those values range from as low as $0.035 \text{ m} \cdot \text{s}^{-1}$ for anguilliform swimming species such as the American eel to as high as $0.11 \text{ m} \cdot \text{s}^{-1}$ for subcarangiform species such as the smallmouth bass. These data suggest that an approach velocity of $0.035 \text{ m} \cdot \text{s}^{-1}$ should be sufficient to protect against impingement for all species potentially present.

4.4.3.2.3 Proposed Mitigation

The environmental protection measures provided below should be implemented by all Project personnel to minimize the potential impact on aquatic flora and fauna.

- A Project-specific environmental protection plan will be developed to provide best-management practices that all Project personnel should follow in order to limit the potential for impacts to aquatic flora and fauna to occur. {Applicable to Stages II, III, and V}
- All Project personnel should be briefed on the potential impacts the Project may have on aquatic flora and fauna. {II, III, and V}
- Mitigation measures developed and included in the Project-specific environmental protection plan should be adhered to in order to adequately address potential impacts. {II, III, and V}
- An erosion and sedimentation control plan, which may form part of the Project-specific environmental protection plan, should be developed and implemented prior to completing any onsite works and may include the installation and management of structures, such as strawbale barriers, rock check dams, silt fences, *etc.*, to limit and control erosion and sedimentation. {II, III, and V}
- Erosion and sediment control structures should be regularly inspected and maintained according to the Project-specific environmental protection plan to ensure they continue to protect against erosion and sedimentation. {II, III, and V}
- A surface water drainage management plan, which may form part of the Project-specific environmental protection plan, should be developed and implemented prior to completing any onsite works and may include the use of ditches and settling basins to control surface water flow and to reduce sediment concentrations in water prior to discharge from the site. {II, III, and V}

- Refueling and maintenance of equipment should occur in designated areas, on level terrain, a minimum of 30 m from any watercourse and / or wetland. {II, III, and V}
- Appropriately stocked and maintained spill response equipment (*i.e.*, spill kits) should be located at all fuel storage and fueling / lubricating / servicing locations. {II, III, and V}
- Heavy equipment working in or within 30 m of watercourses and / or wetlands should use eco-friendly biodegradable and non-toxic hydraulic fluids as opposed to petroleum-based hydraulic fluids. {II, III, and V}
- When pile driving within Mill Cove, contractors should position their vessels and water-borne equipment associated with pile driving in a manner that will prevent damage to fish habitat and the work should be done during periods of reduced sensitivity, such as between 1 June and 30 September. {II}
- Vibratory hammers should be used whenever possible to drive piles underwater instead of high-energy drop hammers. {II}
- Underwater peak pressures associated with pile driving should not exceed 30 kPa, which are levels likely to adversely affect fish. The use of netting and silt curtains should be used to prevent fish from entering the work area where underwater pile driving shock waves might exceed 30 kPa and the use of a bubble curtain should be used to attenuate shock waves radiating out from the pile where underwater shock waves might exceed 30 kPa. {II}
- The design of the high capacity, low-velocity passive intake screens will be included in the *Fisheries Act* authorization application. {III and V}
- The high-capacity, low-velocity passive intake screens should be located in areas and depths of water with low concentrations of fish throughout the year. {III and V}
- The high-capacity, low-velocity passive intake screens should be located away from natural and anthropogenic structures that may attract fish that are migrating, spawning, or in rearing habitat. {III and V}
- The high-capacity, low-velocity passive intake screens should be oriented parallel to the Saint John River's flow. {III and V}
- The high-capacity, low-velocity passive intake screens should be located a minimum of 300 mm above the bed of the Saint John River to prevent entrainment of sediment and benthic organisms. {III and V}
- The high-capacity, low-velocity passive intake screens should be cleaned regularly and maintained in good condition to protect against fish impingement and entrainment. {III and V}
- Emergency response and contingency plans should be designed to prevent any sustained environmental damage during any errors, mishaps, and / or unforeseen events. {V}

4.4.3.2.4 Potential Post-Mitigation Residual and Cumulative Impacts

No residual and cumulative effects are likely to occur to aquatic flora and fauna over the duration of the construction and operation of the Project assuming the above mitigation measures are implemented.

Table 55. Assessment of potential impacts on terrestrial flora and fauna of the proposed environmental treatment facility and water use reduction project at the Reversing Falls Mill in Saint John, New Brunswick.

Potential Impact	Stage II: Construction			Stage III: Operation and Maintenance			Stage V: Mishaps, Errors, and / or Unforeseen Events		
	Degree of Impact	Pathways	Mitigation	Degree of Impact	Pathways	Mitigation	Degree of Impact	Pathways	Mitigation
Species of concern (<i>i.e.</i> , SARA and COSWEIC listed)		1 to 4	A to E		1 to 4	A to E		1 to 4, 14	A to E, V
Flora and habitat		1, 2, 5 to 8	A, B, C, F		1, 2, 7	A, B, C		1, 2, 7, 14	A, B, C, V
Flora associations and biodiversity									
Fauna (<i>i.e.</i> , birds, animals, and mammals) and habitat (<i>i.e.</i> , direct and indirect)									
Fauna and habitat fragmentation									
Fauna migration patterns (<i>i.e.</i> , migratory birds), nesting and food chains		9, 10, 11	A to U		12, 13	A to E, H, J to U		14	A to E, H, J to V

PATHWAYS

- 1 – The Project site is almost devoid of any terrestrial flora and fauna (*n.b.*, transients / vagrants / migrants can make their way through the site).
- 2 – No *Species At Risk Act* listed species (*i.e.*, provincial and federal) or Committee On the Status of Endangered Wildlife In Canada listed species were observed during the various field assessments completed at the Project site; however, Atlantic Canada Conservation Data Centre records suggest that some transient / vagrant / migrant species of special conservation concern or rare species do exist within a 5 km radius of the site, such as the barn swallow, Drummond's rockcress, and the monarch butterfly. Therefore, there is a possibility that they could pass through the site on occasion.
- 3 – Sound and light emitted from heavy equipment and / or construction / operation activity may scare away / displace wildlife from the Project site and / or adjacent areas.
- 4 – The New Brunswick Department of Natural Resources and Energy Development lists the wood turtle, bald eagle, and peregrine falcon as location-sensitive species for the area, but the various assessments completed at the Project site did not yield their presence. Regardless, there is a possibility that they could exist or pass through the site on occasion.
- 5 – Although none are known to be present at the site, loss of vegetation could result in the loss of a species of special concern.
- 6 – Topsoil removal could result in the loss of the native plant seed bank, nutrients, organic matter, and microorganisms that are essential for plant growth.
- 7 – Dusts emitted from the Project site (*e.g.*, vehicle traffic on roadways, wind erosion of aggregate stockpiles, *etc.*) may land on vegetation and affect primary production (*i.e.*, by impacting photosynthesis, respiration, and transpiration and allowing the penetration of phytotoxic gaseous pollutants).
- 8 – Increased overland flow due to vegetation clearing and grubbing may reduce the amount of water available, captured, and stored for vegetation.
- 9 – Ground spills of hydrocarbons during refueling operations (*i.e.*, gasoline and diesel) may contaminate food and water sources for wildlife.
- 10 – If refuse from Project personnel is not stored properly, it may be an attraction for wildlife, which could result in unwanted interactions between humans and wildlife.
- 11 – During vegetation clearing, injury or death of invertebrates, amphibians, reptiles, birds, and / or small mammals may occur.
- 12 – Once the Project is in operation, there should be little impact to natural wildlife migration, nesting, and food chains.
- 13 – Hydrocarbon (*e.g.*, lubricating oils, gasoline, diesel, *etc.*) and chemical leaks (*e.g.*, polymers, acids, *etc.*) from the various processing equipment may spill on to the ground and could contaminate food and water sources for wildlife.
- 14 – Depending on the mishap, error, and / or unforeseen event, there is a possibility the impact could be long-lasting and could extend offsite to affect a species of special conservation concern.

MITIGATION

- A – A Project-specific environmental protection plan will be developed to provide best-management practices that all Project personnel should follow in order to limit the potential for impacts to terrestrial flora and fauna to occur.
- B – All Project personnel should be briefed on the potential impacts the Project may have on terrestrial flora and fauna.
- C – Mitigation measures developed and included in the Project-specific environmental protection plan should be adhered to in order to adequately address potential impacts.
- D – A perimeter fence should be erected at the boundary of the Project site to keep the majority of land-based wildlife from accessing the site.
- E – Extremely loud, intrusive, or otherwise potentially harassing activities (*e.g.*, pile driving, *etc.*) should be avoided or limited during periods of the year when wildlife are under severe environmental and physiological stress, such as the spring breeding season for birds.
- F – Any sensitive flora should be salvaged and relocated from the Project site.
- G – Any vegetation clearing activity should be undertaken outside of the migration and breeding season for migratory birds (*i.e.*, 5 April through 31 August in the Greater Saint John region).
- H – If species listed under the federal *Species At Risk Act* [S.C. 2002, c. 29] are observed on the Project site, then their sightings will be reported to Environment and Climate Change Canada's Canadian Wildlife Service branch and if a species listed under the provincial *Species At Risk Act* [R.S.N.B. 2012, c 6] are observed on the Project site, then their sightings will be reported to the New Brunswick Department of Natural Resources and Energy Development.
- I – Equipment should arrive at the Project site in a clean condition free of invasive and noxious weeds.
- J – All Project personnel should report all unusual wildlife encounters to the Project supervisor during construction and to the Environmental Manager during operation.
- K – Project personnel should properly dispose of food scraps and garbage in the appropriate onsite receptacles, such as "predator-proof" garbage bins provided by the contractor or proponent.
- L – Waste stored onsite should be stowed in an appropriate manner and be transported to an appropriate disposal facility (*e.g.*, Crane Mountain Landfill, *etc.*) on a regular basis.
- M – Project personnel should be advised, prior to working on the Project site, to not feed or harass nuisance wildlife (*e.g.*, varmint, pigeons, sea gulls, rodents, *etc.*).
- N – Heavy equipment and other vehicles used on the Project site should yield the right-of-way to wildlife.
- O – No attempt should be made to chase, catch, divert, follow, or otherwise harass any wildlife by vehicle or on foot.
- P – If injured or deceased wildlife are encountered, then representatives with the New Brunswick Department of Natural Resources and Energy Development and Canadian Wildlife Service should be contacted to determine the appropriate course of action.

Q – If deceased animals are encountered, they should be removed and disposed of as soon as possible in consultation with representatives of the New Brunswick Department of Natural Resources and Energy Development and Canadian Wildlife Service.

R – No Project personnel should affect wildlife populations by either hunting or trapping and firearms should be strictly prohibited on the Project site.

S – If an active nest, den, *etc.* is encountered, a no-disturbance buffer zone of 30 m+ should be established around the area (*n.b.*, flagging tape should not be used to mark the feature as it increases the chance of predation and representatives with the Canadian Wildlife Service should be contacted to determine the appropriate buffer size) until a qualified biologist determines if the buffer zone shall remain, if the size should be increased, or if the buffer zone can be eliminated (*i.e.*, the animal has abandoned the feature).

T – No Project personnel should deposit or permit to be deposited oil, oil wastes, or any other substance harmful to wildlife in any waters or any area frequented by wildlife.

U – An oil spill prevention and response plan should be developed as part of the Project-specific environmental protection plan.

V - Emergency response and contingency plans should be designed to prevent any sustained environmental damage during any mishaps, errors, and / or unforeseen events.

Table 56. Assessment of potential impacts on aquatic flora and fauna of the proposed environmental treatment facility and water use reduction project at the Reversing Falls Mill in Saint John, New Brunswick.

Potential Impact	Stage II: Construction			Stage III: Operation and Maintenance			Stage V: Mishaps, Errors, and / or Unforeseen Events		
	Degree of Impact	Pathways	Mitigation	Degree of Impact	Pathways	Mitigation	Degree of Impact	Pathways	Mitigation
Species of concern (<i>i.e.</i> , SARA and COSWEIC listed)		1 to 4	A to L		6, 7	A to I		10	A to I, S
Flora and habitat		2 to 5	A to L		6, 7	A to I		10	A to I, S
Flora associations and biodiversity									
Fauna (<i>e.g.</i> , fish, mammals, <i>etc.</i>) and habitat (<i>i.e.</i> , direct and indirect)		2 to 5	A to L		6, 7	A to I		10	A to I, S
Fauna and habitat fragmentation									
Fauna migration patterns (<i>i.e.</i> , anadromous fishes) and food chains									
Fish impingement and entrainment					8, 9	M to R		10	M to S

PATHWAYS

- 1 – Installation of the cooling water intake could affect known species of conservation concern that frequent the estuarial waters of the Saint John River in the vicinity of the Mill (*i.e.*, American eel and striped bass).
- 2 – Increased erosion potential and exposed sediments due to vegetation clearing may be entrained in overland flow and transported to the Saint John River via engineered surface water runoff collection systems (*i.e.*, ditches, trenches, and ponds) where entrained sediments (*i.e.*, elevated levels of total suspended sediments) may affect the water quality.
- 3 – Ground spills of hydrocarbons during refueling operations (*i.e.*, gasoline and diesel) may allow hydrocarbons to be introduced to surface water systems and cause contamination with lethal or sub-lethal results.
- 4 – Shock waves and vibrations from rock breaking activities and pile driving activities could have lethal (*i.e.*, damage to the swim bladder of fishes or rupture of internal organs) or sub-lethal (*i.e.*, behavioural) effects on aquatic fauna (*i.e.*, avoidance of preferred habitat, changes to migration, reduced feeding, and / or reduced schooling that could increase predation).
- 5 – Installation of the cooling water intake could affect aquatic flora and fauna and / or their habitat within Mill Cove.
- 6 – The long-term operation and maintenance of the Project is expected to have little to no impact on any aquatic flora and fauna.
- 7 – Spills from the environmental treatment facility plant during operation and maintenance activities may allow untreated effluent to be introduced to surface water systems and cause contamination with lethal or sub-lethal results to aquatic flora and / or fauna.
- 8 – Intake of water for the cooling water system could impinge or entrain known species of conservation concern that frequent the estuarial waters of the Saint John River in the vicinity of the Mill (*i.e.*, American eel and striped bass).
- 9 – Intake of water for the cooling water system could impinge or entrain aquatic flora and fauna within Mill Cove.
- 10 – If there is a mishap, error, and / or unforeseen event it may have an impact on aquatic flora and fauna.

MITIGATION

- A – A Project-specific environmental protection plan will be developed to provide best-management practices that all Project personnel should follow in order to limit the potential for impacts to aquatic flora and fauna to occur.
- B – All Project personnel should be briefed on the potential impacts the Project may have on aquatic flora and fauna.
- C – Mitigation measures developed and included in the Project-specific environmental protection plan should be adhered to in order to adequately address potential impacts.
- D – An erosion and sedimentation control plan, which may form part of the Project-specific environmental protection plan, should be developed and implemented prior to completing any onsite works and may include the installation and management of structures, such as strawbale barriers, rock check dams, silt fences, *etc.*, to limit and control erosion and sedimentation.
- E – Erosion and sediment control structures should be regularly inspected and maintained according to the Project-specific environmental protection plan to ensure they continue to protect against erosion and sedimentation.
- F – A surface water drainage management plan, which may form part of the Project-specific environmental protection plan, should be developed and implemented prior to completing any onsite works and may include the use of ditches and settling basins to control surface water flow and to reduce sediment concentrations in water prior to discharge from the site.
- G – Refueling and maintenance of equipment should occur in designated areas, on level terrain, a minimum of 30 m from any watercourse and / or wetland.
- H – Appropriately stocked and maintained spill response equipment (*i.e.*, spill kits) should be located at all fuel storage and fueling / lubricating / servicing locations.
- I – Heavy equipment working in or within 30 m of watercourses and / or wetlands should use eco-friendly biodegradable and non-toxic hydraulic fluids as opposed to petroleum-based hydraulic fluids.
- J – When pile driving within Mill Cove, contractors should position their vessels and water-borne equipment associated with pile driving in a manner that will prevent damage to fish habitat and the work should be done during periods of reduced sensitivity, such as between 1 June and 30 September.
- K – Vibratory hammers should be used whenever possible to drive piles underwater instead of high-energy drop hammers.
- L – Underwater peak pressures associated with pile driving should not exceed 30 kPa, which are levels likely to adversely affect fish. The use of netting and silt curtains should be used to prevent fish from entering the work area where underwater pile driving shock waves might exceed 30 kPa and the use of a bubble curtain should be used to attenuate shock waves radiating out from the pile where underwater shock waves might exceed 30 kPa.
- M – The design of the high capacity, low-velocity passive intake screens will be included in the *Fisheries Act* authorization application.
- N – The high-capacity, low-velocity passive intake screens should be located in areas and depths of water with low concentrations of fish throughout the year.
- O – The high-capacity, low-velocity passive intake screens should be located away from natural and anthropogenic structures that may attract fish that are migrating, spawning, or in rearing habitat.
- P – The high-capacity, low-velocity passive intake screens should be oriented parallel to the Saint John River's flow.
- Q – The high-capacity, low-velocity passive intake screens should be located a minimum of 300 mm above the bed of the Saint John River to prevent entrainment of sediment and benthic organisms.
- R – The high-capacity, low-velocity passive intake screens should be cleaned regularly and maintained in good condition to protect against fish impingement and entrainment.
- S – Emergency response and contingency plans should be designed to prevent any sustained environmental damage during any errors, mishaps, and / or unforeseen events.

4.4.4 Socio-Economic Environment

4.4.4.1 Labour and Economy

Labour and economy play a distinct role in the EIA process. As described in Section 2.8.2.5, this Project has the potential to substantially and positively affect the local labour market and economy. Therefore, labour and economy were selected as a VEC because environmental impacts will likely occur through economic linkages.

4.4.4.1.1 Conceivable Impacts and Pathways

Impacts to labour and economy will occur throughout all stages of the Project, but will be most pronounced during construction. Table 57 links conceivable positive and negative impacts and pathways to labour and economy for the various Project stages.

Table 57. The type of cause-effect relationships that are possible and the mechanisms by which stressors could ultimately lead to impacts on labour and economy during various stages associated with the proposed environmental treatment facility and water use reduction project at the Reversing Falls Mill in Saint John, New Brunswick.

Project Stage	Conceivable Impacts and Pathways
Project construction	<ul style="list-style-type: none"> ➤ Skilled labour (<i>e.g.</i>, surveyors, engineers, carpenters, heavy equipment operators, electricians, pipefitters, boilermakers, <i>etc.</i>) will be required to build the Project and some of wages will be used to purchase goods and services ➤ Demand for local goods (<i>i.e.</i>, construction materials) and services (<i>e.g.</i>, construction equipment, construction materials, restaurant and hospitality, <i>etc.</i>) will increase due to those workers required to build the Project ➤ Demand for skilled labour during peak construction periods may be too much for the local labour market to bear, which could put upward pressure on wages
Project operation and maintenance	<ul style="list-style-type: none"> ➤ About five full-time permanent personnel will be required to operate and maintain the environmental treatment facility generating wages and salaries that will be spent locally ➤ Federal and provincial taxes will be paid during the operational lifespan of the Project ➤ Annual property taxes will be paid to the municipality (<i>i.e.</i>, Saint John) ➤ Goods and services will be required to operate and maintain the Project, such as polymers and nutrients ➤ Periodic maintenance shutdowns will require skilled labour
Project errors, mishaps, and / or unforeseen events	<ul style="list-style-type: none"> ➤ Errors, mishaps, and / or unforeseen events could result in a short-term or long-term stoppage in work ➤ Depending on the error, mishap, and / or unforeseen event, employment may be generated (<i>e.g.</i>, cleanup of a spill, <i>etc.</i>) ➤ Depending on the error, mishap, and / or unforeseen event, there may be a need for new or upgraded infrastructure

Based on the conceivable impacts and pathways identified in Table 57, the following specific potential impacts were assessed:

- employment / workforce retention;
- skills training;
- local spending; and
- livelihood.

4.4.4.1.2 Potential Impacts

Table 63 presents the anticipated impact of the proposed Project on the local labour market and economy. It is believed that the Project will yield primarily positive and significant impacts to Saint John and the surrounding communities. Such benefits include the creation of skilled jobs as the economy rebounds from the effects of the COVID-19 global pandemic and subsequent increase in local spending (e.g., through local suppliers, within local retail establishments and restaurants, etc.). Therefore, the Project was given green lights for the majority of potential impacts ($n = 11$) related to the local labour market and economy.

If there was a catastrophic event within the ETF, then there is the potential that regular employment could be reduced until such time that the situation is rectified; however, such a situation would likely result in the increase in employment to third-party contractors required to remedy the situation. That is the reason why green lights were applied to the majority of impacts during that Project stage (Table 63).

4.4.4.1.3 Proposed Mitigation

This Project is extremely positive for the local labour market and economy. Locally, the unemployment rate remains at or above 8.5 % as the economy deals with the effects of the COVID-19 global pandemic. This Project will provide much needed construction jobs in the region. There are no negative impacts anticipated save for potential impacts to employment, skills training, and livelihood in the case of a mishap, error, and / or unforeseen event; however, those negative impacts would be short-term and easily mitigated. No additional mitigation measures, other than those highlighted in Table 63 are required.

- Data indicate that there is ample room to grow employment in the local labour market (i.e., unemployment rates remain at or above 8.5 %). {Applicable to Stage II}
- Considering local unemployment rates, but subject to skills, availability, costs, and quality, hiring from the local workforce should be a priority for contractors to the maximum extent possible before going outside the region. {II}
- Local and regional construction associations and labour unions may have to coordinate the quantity of available workers with the contractors should other large-scale industrial projects be announced for the region. {II}
- The proponent should develop employment and procurement programs that promote opportunities for local workers and local businesses. {II and III}
- Mitigation measures developed for this Project should be adhered to in order to adequately address any potential impacts in order to minimize the amount of lost work time. {V}

With respect to the above mitigation measures, the Proponent considers “local” to be the Maritime Provinces. Indigenous persons or communities, which are considered local, as well as all local persons are welcome to participate in the employment and procurement programs.

4.4.4.1.4 Potential Post-Mitigation Residual Impacts

There will be positive residual impacts (*i.e.*, skills development and income generation) that do not require mitigation. No negative residual effects are likely to be incurred within the local labour market and economy due to this Project.

4.4.4.2 Archaeological and Cultural Resources

First Nations have occupied lands throughout New Brunswick for time immemorial. As noted in Section 3.3.4, if the tide was not optimal for traversing Reversing Falls, First Nations would portage around the Falls. Samuel de Champlain's 1604 map showed a portage route located on the opposite side of the River from the Mill site (*i.e.*, Figure 69). When representatives with the New Brunswick Museum were considering an expansion at their Douglas Avenue location in Saint John, archaeologists found evidence of an ~ 4 400 year old campsite along that portage route [CBC, 2016].

There are no known archaeological and cultural resources on the Mill site; however, it is possible that a portage route may have existed on the Mill side of the River or could have at one time. Additionally, it is plausible that First Nations camped on the lands surrounding Reversing Falls if the tides were not optimal for navigating or if they were staying in the area of a period of time. Some of the lands where the ETF will be located have not been previously impacted by Mill operations (*i.e.*, topographically high areas in the vicinity of the indirect air coolers, primary clarifiers, and MBBRs) and there could be archaeological and cultural resources located there. Therefore, archaeological and cultural resources were selected as VEC.

4.4.4.2.1 Conceivable Impacts and Pathways

Activities and physical works that may occur during the Project stages along with the conceivable impacts and pathways are summarized in Table 58. In the section that follows, the potential impacts were assessed in concert with the development of mitigation measures.

Table 58. The type of cause-effect relationships that are possible and the mechanisms by which stressors could ultimately lead to impacts on archaeological and cultural resources during various activities associated with the proposed environmental treatment facility and water use reduction project at the Reversing Falls Mill in Saint John, New Brunswick.

Activity	Conceivable Impacts and Pathways
Vegetation clearing, grubbing, stripping, grading, and site development	<ul style="list-style-type: none"> ➤ Vegetation removal and ground disturbing exercises can damage or destroy archaeological and cultural resources ➤ Vandalism of archaeological and cultural resources either by personnel and / or the general public
Operation and maintenance of heavy equipment	<ul style="list-style-type: none"> ➤ Vibrations from heavy equipment could cause damage to archaeological or cultural resources ➤ Ground spills of hydrocarbons during refueling operations (<i>i.e.</i>, gasoline and diesel) may allow hydrocarbons to infiltrate the ground and impact buried resources ➤ Leaks of hydraulic fluids, oils, <i>etc.</i> during normal operations may spill on to the ground and infiltrate the subsurface where they may impact buried resources

Rock breaking and excavating with pneumatic hammers	<ul style="list-style-type: none"> ➤ Fracturing of rock can increase oxygen ingress into undisturbed layers, which could cause increased decay or corrosion of buried resources ➤ Shock waves and vibrations could cause damage to buried resources
Stockpiling of soils and rock	<ul style="list-style-type: none"> ➤ Stockpiling of materials onsite and could hide resources or destroy them
Temporary construction personnel sanitary facilities	<ul style="list-style-type: none"> ➤ Leaks or spills on the ground during use or maintenance may cause untreated sanitary waste to be introduced to the subsurface, which could affect buried resources
Storage and handling of various hazardous chemicals	<ul style="list-style-type: none"> ➤ Leaks or spills on the ground during the handling and storage of hazardous chemicals (<i>e.g.</i>, hydrocarbons, paints, solvents, polymers, acids, <i>etc.</i>) may be introduced to the subsurface, which could affect buried resources
Footing and foundation construction	<ul style="list-style-type: none"> ➤ Dewatering activities may cause sediment layers to dry out, which could stimulate biodegradation of preserved resources
Dust suppression and winter roadway clearing	<ul style="list-style-type: none"> ➤ If chemical dust suppressants are used on roadways, they may be entrained in surface waters and / or groundwater and come in to contact with buried resources ➤ If salt is used for winter roadway maintenance, it may be entrained in surface waters and / or groundwater and come in to contact with buried resources
Temporary storage of construction and hazardous waste	<ul style="list-style-type: none"> ➤ Precipitation may come in contact with construction and hazardous waste that is temporarily stored onsite prior to safe disposal, which may cause water to become contaminated and subsequently transported to and contaminate water that may come in to contact with archaeological or cultural resources
Effluent pipeline or effluent treatment tank leaks	<ul style="list-style-type: none"> ➤ During operation, leaks could enter surface waters and / or groundwater and come in to contact with buried resources

Based on the conceivable impacts and pathways identified in Table 58, the following specific potential impacts were assessed for archaeological and cultural resources:

- damage / destruction of archaeological sites and landmarks;
- damage / destruction of cultural sites and landmarks;
- conflict with ancestral remains; and
- conflict with cultural domains.

4.4.4.2.2 Potential Impacts

Table 64 provides a summary of the impact assessment for archaeological and cultural features. The majority of the potential impacts yielded yellow lights ($n = 8$) while the remainder yielded green lights ($n = 4$).

There are no known archaeological and / or cultural resources within the Project footprint and nothing was noted in any of the 11 test pits and 15 boreholes completed within the footprint of the ETF. Therefore, the probability of an encounter is considered low. Should accidental disruption / destruction of an unknown resource occur, the magnitude of that impact is considered moderate (*e.g.*, the resource could be damaged, be removed from its contextual setting, *etc.*) and the impact would likely be irreversible.

Potential impacts are considered most probable during the construction stage when ground disturbance activities are taking place. Potential impacts are also possible should any errors, mishaps, and / or unforeseen events occur. While the Project is in operation,

potential impacts are considered negligible because ground disturbance exercises will not be occurring.

4.4.4.2.3 Proposed Mitigation

The mitigation measures listed below will be followed to minimize the potential impact on archaeological and cultural resources during Project works.

- An archaeological resources protection plan, which may form part of the Project-specific environmental protection plan, should be developed and implemented prior to completing any onsite Project works. {Applicable to Stage II and V}
- IPP will engage the Wolastoqey Nation in New Brunswick to train contractors and employees on their *Accidental Discovery of Archaeological Resources Protocol*. {II and V}
- If deemed necessary, an archaeological testing regime should be conducted to determine the presence or absence of buried cultural resources within the footprint of the environmental treatment facility. {II}
- Site security measures, in the form of a perimeter fence, should be erected prior to Project construction in order to limit entry to the site in order to protect any potential archaeological and cultural resources that may exist. {II}
- The Wolastoqey Nation in New Brunswick should be contacted immediately at 506.459.6341 if any archaeological or cultural resource is discovered as outlined in the *Accidental Discovery of Archaeological Resources Protocol*. {II and III}
- Any archaeological or cultural feature discovered should be reported immediately to the appropriate Regulator(s) as per the New Brunswick *Heritage Conservation Act* [S.N.B. 2010, c. H-4.05]. {II}
- If archaeological or cultural resources require removal to facilitate Project development, then excavation, recording, and reporting should occur for those features as per the New Brunswick *Heritage Conservation Act* [S.N.B. 2010, c. H-4.05]. {II}
- Should any human remains be discovered, the Saint John Police Force will be contacted to determine if the remains are an archaeological or cultural resources whereupon they will contact the appropriate authorities to have a licensed Resource Archaeologist examine the remains. {II, III, V}

4.4.4.2.4 Potential Post-Mitigation Residual Impacts

By implementing the mitigation measures and standards prescribed by regulatory authorities, residual impacts on archaeological and cultural features as a result of the Project are expected to be negligible.

4.4.4.3 Transportation Network

Saint John's transportation network is fundamental to the public living and / or moving throughout the City. Herein, transportation network refers to roadways only and does not include other networks, such as railways, seaways, and skyways because they are not expected to be impacted either at all or to the degree of the public roadway system. A variety of motorized vehicles of different sizes and configurations use the road network, including automobiles, buses, motorcycles, and trucks. Vehicles sharing the roads are

used for private, commercial passenger, and freight transportation activities. The roadways are also used as active transportation routes (e.g., bicycles, walkers, runners, etc.).

4.4.4.3.1 Conceivable Impacts and Pathways

Activities and physical works that may occur throughout the Project that could potentially impact the transportation network are summarized in Table 59 along with their associated impact pathways. In the section that follows, the potential impacts are assessed in concert with the development of mitigation measures.

Table 59. The type of cause-effect relationships that are possible and the mechanisms by which stressors could ultimately lead to impacts on the transportation network during various activities associated with the proposed environmental treatment facility and water use reduction project at the Reversing Falls Mill in Saint John, New Brunswick.

Activity	Conceivable Impacts and Pathways
Transporting materials and equipment (e.g., building supplies, polymers, nutrients, etc.) to and from the site (i.e., via tractor trailers, vans, pick-up trucks, and other delivery vehicles)	<ul style="list-style-type: none"> ➤ Increase in traffic volumes along local road networks ➤ Increase in travel times along local road networks (e.g., due to traffic, etc.) ➤ Traffic delays or disruptions to accommodate wide loads (i.e., due to use of escorts or loads that are too wide for single lane transportation) ➤ Damage to road surfaces and associated infrastructure (e.g., bridges, etc.) due to wide and / or heavy loads ➤ Conflicts with active transportation routes (e.g., bikes on roadways, use of roadway shoulders as walking routes, etc.) ➤ Increase in traffic accidents
Transporting contractors and employees to and from the site	<ul style="list-style-type: none"> ➤ Increase in traffic volumes along local road networks ➤ Change in traffic volumes and patterns along local road networks (i.e., rush hour traffic times may shift and / or be extended) ➤ Increase in travel times along local road networks (i.e., due to traffic) ➤ Damage to road surfaces and associated infrastructure (e.g., bridges, etc.) due to traffic volumes and load weights ➤ Conflicts with active transportation routes (e.g., bikes on roadways, use of roadway shoulders as walking routes, etc.) ➤ Increase in traffic accidents

Through this Project, the local transportation network will see a moderate increase in heavy equipment traffic (e.g., the delivery of construction equipment and Project infrastructure, etc.). Additionally, during peak construction, dozens of workers are expected to be at the Mill site working specifically on the Project (i.e., refer to Section 2.8.2.5). The potential impacts that were assessed with respect to the local transportation network were:

- traffic hazards;
- damage to infrastructure; and
- conflict with existing traffic.

4.4.4.3.2 Potential Impacts

The movement of heavy equipment in and out of the Mill site is a normal everyday occurrence. Trucks and trains regularly import wood chips and other production materials and export Kraft pulp and by-products. It is also common for the Mill to experience rapid and large increases in workforce and the associated vehicle traffic. For example, during routine Mill maintenance, shutdowns, and upgrades, there are often hundreds of workers onsite. Effective project management by IPP personnel in the past has ensured that maintenance, shutdown, and upgrade traffic and employment numbers were smoothly integrated into regular operations. Furthermore, work has been done over the previous decade to improve safety surrounding vehicles entering and exiting the Mill site (e.g., the number of access points have been reduced, sight lines have been increased, etc.).

There is sufficient space for all material excavated to remain onsite. As such there will be limited heavy equipment traffic going to and from the site on a daily basis during Project construction. During operations, delivery of materials will be infrequent (i.e., a few trucks per week for the Project).

The impact assessment for the local transportation network yielded all green lights (Table 65). This is because the impacts will likely be imperceptible from existing operations, save for during peak construction when up to 130 contractor employees may be working at the site. During that period, a slight increase in traffic may be experienced.

4.4.4.3.3 Proposed Mitigation

In addition to the normal project management practices undertaken at the Mill during routine operations and during Mill maintenance, shutdowns, and upgrades, the measures provided below should be implemented by all Project personnel to minimize the potential impact on the local transportation network.

- All Project vehicles used on local roadways should be maintained according to provincial regulations with respect to licensing, insurance, and safety inspection. {Applicable to Stages II, III, and V}
- No vehicles associated with Project work (i.e., personnel vehicles, construction vehicles, heavy equipment, etc.) should be allowed to park along roadways; parking should only occur in safe and identified locations. {II, III, and IV}
- All Project personnel operating vehicles permitted on local roadways should obey the posted speed limits and other posted signs, such as weight restrictions. {II, III, and IV}
- Carpooling of workers, while adhering to social distancing measures while under COVID-19 restrictions, should be encouraged during Project construction in order to reduce traffic volumes. {I and V}
- Road traffic control measures (e.g., use of flaggers, escort crews, etc.) should be used when transporting over-sized loads on public roadways using trained traffic personnel in accordance with the New Brunswick Department of Transportation and Infrastructure standards and practices. {II, III, and V}
- Any additional mitigation measures developed for this Project should be adhered to in order to adequately address any potential impacts. {II, III, and V}
- Heavy equipment haulers and shippers should adhere to weight restrictions and

- load limits as designated by the New Brunswick Department of Transportation and Infrastructure. {II, III, and V}
- To avoid traffic congestion, movement of heavy equipment and materials to and from the Mill site during Project construction should be scheduled outside of normal peak traffic hours (*i.e.*, 7:30 AM to 8:30 AM and 4:30 PM to 5:30 PM Monday through Friday). {II, III, and V}

4.4.4.3.4 Potential Post-Mitigation Residual and Cumulative Impacts

No residual and cumulative effects are likely to be incurred to the local transportation network due to this Project.

4.4.4.4 Aesthetics

Saint John is known as an industrial city and its economy is heavily focused on industrial and manufacturing operations. As noted in Section 3.3.5, a Mill has existed at Reversing Falls since at least 1836. Within PlanSJ [*Urban Strategies Inc.*, 2011], industrial operations are recognized as being critical to economic growth locally and regionally. Although industrial projects critical to sustaining and growing Saint John's economy, it is necessary to ensure that industrial development is sited appropriately such that it does not negatively impact surrounding non-industrial land uses.

The Mill site is zoned Heavy Industrial, which allows for the most intense industrial operations to occur. Properties abutting the Mill site have a variety of zoning types including (Figure 92):

- neighbourhood community facility (*i.e.*, Saint Rose of Lima Church);
- two-unit residential (*i.e.*, properties along Milford Road);
- mid-rise residential (*e.g.*, properties along Morris Street, Collins Street, *etc.*);
- heavy industrial (*i.e.*, Moosehead Breweries); and
- park land (*i.e.*, Wolastoq Park).

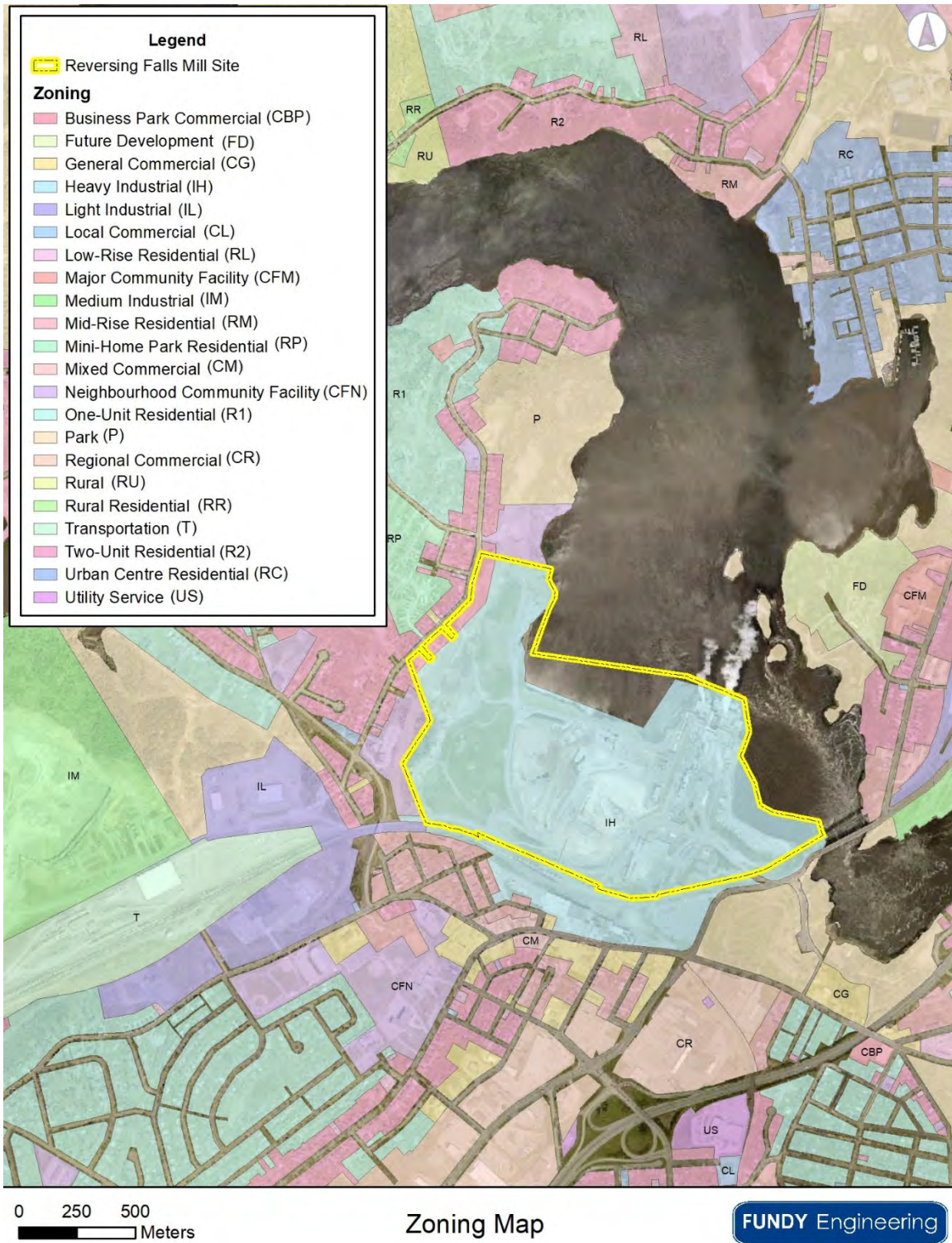

Figure 92. City of Saint John, New Brunswick zoning map in the vicinity of Reversing Falls Mill.

4.4.4.4.1 Conceivable Impacts and Pathways

Activities and physical works that may occur during the Project that may impact aesthetics are summarized in Table 60. Sound emissions are not included within the assessment of aesthetics as they were assessed as their own standalone VEC (*i.e.*, refer to Section 4.4.2.2).

Table 60. The type of cause-effect relationships that are possible and the mechanisms by which stressors could ultimately lead to impacts on aesthetics during various activities associated with the proposed environmental treatment facility and water use reduction project at the Reversing Falls Mill in Saint John, New Brunswick.

Activity	Conceivable Impacts and Pathways
Erection of tall structures	➤ Use of large cranes for hoisting may affect the scenic nature of the area
Low light conditions and nighttime operations	<ul style="list-style-type: none"> ➤ Lights on construction equipment may spill into neighbouring areas ➤ Light emitted from operational employee safety lights may affect use of the areas, particularly during the nighttime (<i>e.g.</i>, for star-gazing, <i>etc.</i>)
Effluent treatment	<ul style="list-style-type: none"> ➤ Emission of unpleasant odours may waft into neighbouring areas ➤ Water vapour plumes generated may block views, reduce visibility, and create shadows for neighbouring residents

Based on the conceivable impacts and pathways identified above, the following specific potential impacts were considered for aesthetics:

- visual pollution (*i.e.*, industrial infrastructure, water vapour plumes, *etc.*);
- light pollution (*i.e.*, light trespass);
- local compatibility; and
- odour.

4.4.4.4.2 Potential Impacts

The impact assessment for aesthetics, which is summarized in Table 66, yielded four green lights, one no change light, and eight yellow lights. The rationale for the assessment is provided below.

The ETF will be located on a hillside of the western Mill site. Rock benches will be created for building the ETF by excavating into the hillside, which will minimize the top elevations of the built infrastructure compared to if they were built on the land as is. Milford Road in this area is at an elevation of about 30 m AMSL. As noted in Table 6, the process building will be the highest component at about 35.4 m AMSL or about 5.4 m higher than Milford Road. A landscaped berm built in three sections, as described in Section 2.7.1.9, will help mask the view of the ETF. Figure 93 through Figure 95 show the modelled ETF and the landscaped berm. Figure 96 and Figure 97 show the ETF looking from two locations on Milford Road with the landscaped berm (*n.b.*, the viewpoints are located about 100 m from the edge of the ETF site).



Figure 93. Conceptual image looking southeast towards the environmental treatment facility proposed for the Reversing Falls Mill in Saint John, New Brunswick. Note: the three sections of the berm are optional.

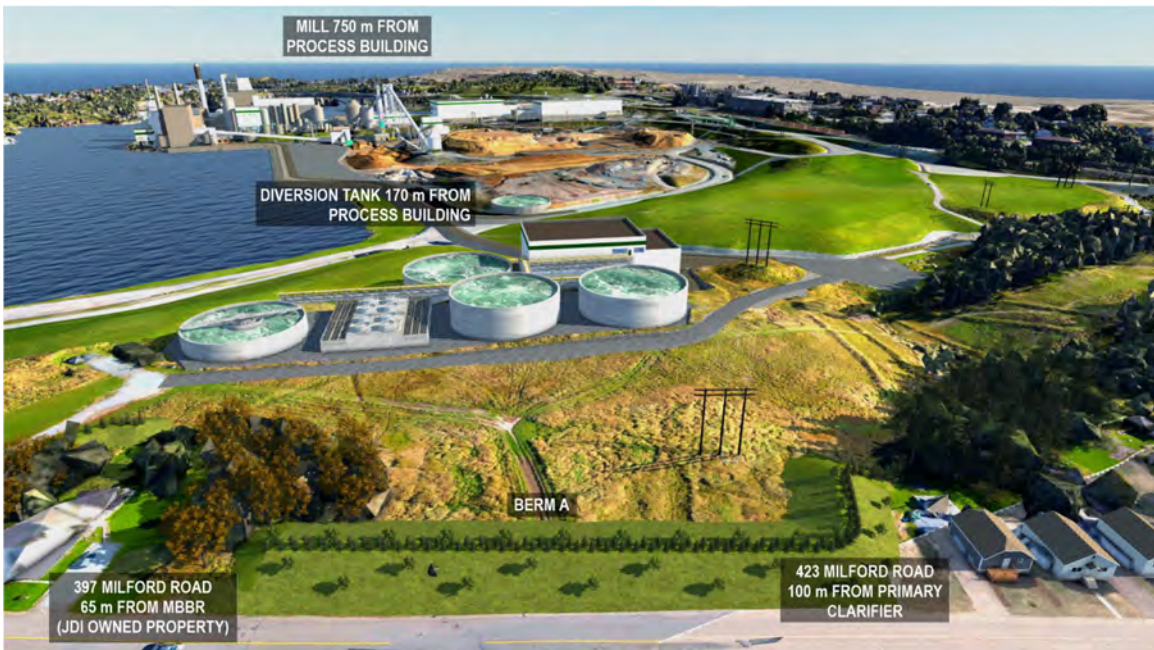

Figure 94. Conceptual image looking east towards the environmental treatment facility proposed for the Reversing Falls Mill in Saint John, New Brunswick. Note: the three sections of the berm are optional.



Figure 95. Conceptual image looking west towards the environmental treatment facility proposed for the Reversing Falls Mill in Saint John, New Brunswick. Note: the three sections of the berm are optional.

Water will be lost to evaporation during operation of the indirect air coolers (*i.e.*, refer to Section 2.7.1.4.3). Evaporation will also occur at the surface of the various treatment tanks as the effluent is mixed and processed. Visible water vapour plumes may be created as a result of that evaporative process particularly during low temperature or high humidity. Those visible plumes may be perceived as aesthetically-unpleasant and they have the potential to cause reduced visibility / shadowing for neighbouring properties.

The indirect air coolers specified for this Project have minimal water consumption requirements and as a result they have the potential to produce minimal visible water vapour plumes. The technology used within the indirect air coolers combines wet and dry bulb cooling for minimized water consumption compared to other cooling technologies. The technology selected will allow operators to choose the running mode depending on ambient temperatures in order to save water and minimize visible water vapour plumes. During cooler months of the year, the system can operate in dry mode to limit visible water vapour plumes.

Exterior lighting will be required for employee safety during low-light and nighttime conditions. As noted in Section 2.7.1.8.1.8, the lighting will balance employee safety criteria with requirements to minimize the effect on the environment and neighbours. The lighting design will be such that light trespass will be minimized by tilting or aiming luminaries away from neighbouring spaces.



Figure 96. Google Earth Street View image circa June 2019 taken between 397 and 423 Milford Road looking east towards the Reversing Falls Mill in Saint John, New Brunswick. Modelled images show the same view with the proposed environmental treatment facility in the background at year 1 and year 5 showing tree growth of the landscaped berm along Milford Road.



Figure 97. Google Earth Street View image circa June 2019 taken near 386 Milford Road looking southeast towards the Reversing Falls Mill in Saint John, New Brunswick. Modelled images show the same view with the proposed environmental treatment facility in the background at year 1 and year 5 showing tree growth of the landscaped berm along Milford Road.

The Mill site has been a hub of industrial activity for more than 185 years. Residential properties have abutted the heavy industrial zones of this area for at least that long. Maps of the City of Saint John from *Roe and Colby* [1875] suggest that the location of the ETF was formerly the location of a distillery (Figure 98). The type of industrial infrastructure, not its presence, will change as a result of this Project.

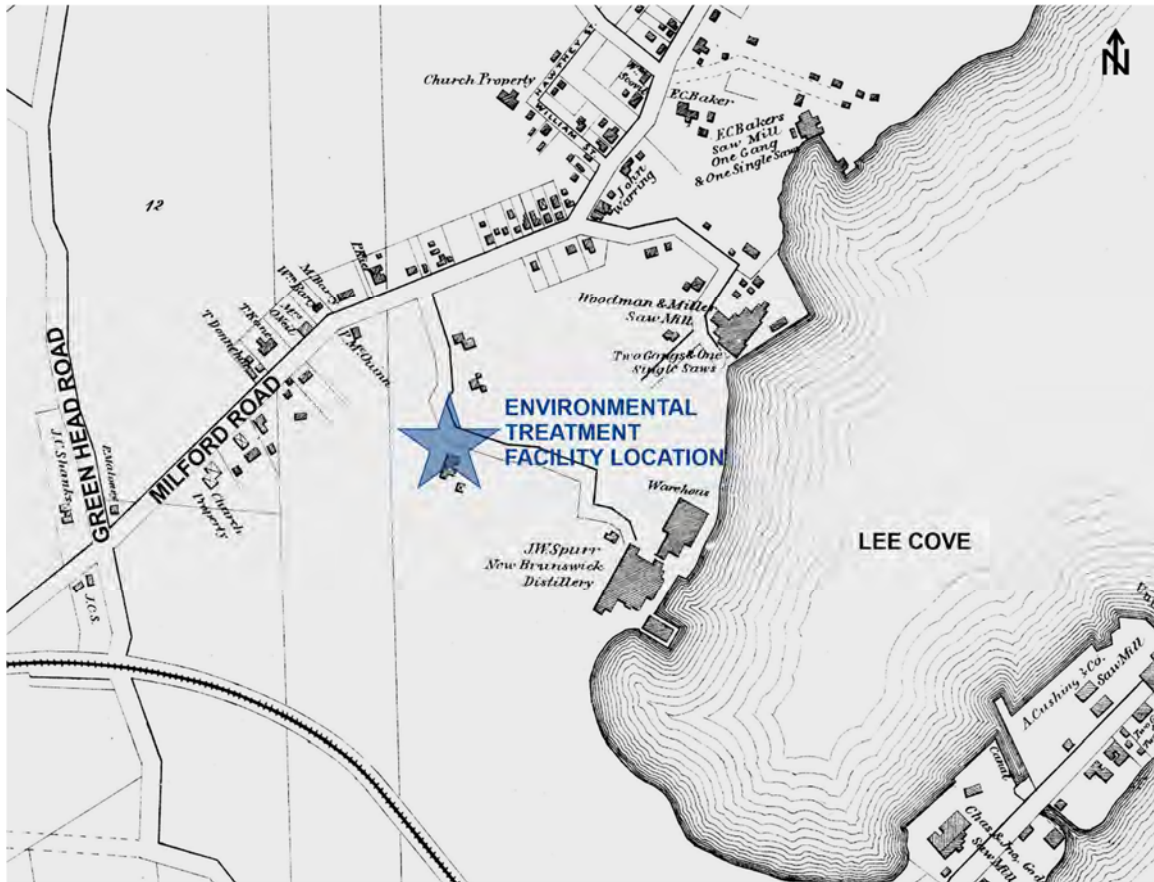

Figure 98. Portion of the 1875 map of Lancaster, New Brunswick showing the location of the proposed environmental treatment facility at the present day Reversing Falls Mill site [Roe and Colby, 1875].

Sulfur emissions from the Mill are typically the substance responsible for odour complaints as human noses are sensitive to the smell of hydrogen sulfide (*i.e.*, < 100 ppb). The EMS for the Mill includes a process for receiving and tracking odour complaints from the public. IPP has implemented several best available technologies over the years to reduce the amount of TRS emitted from the Mill. Between the late 1990s and early 2000s, the Mill reduced TRS emissions by about 80 %, which is demonstrated in the ambient air quality monitoring data included in Section 3.1.2.2. This Project will not result in any material changes to the current TRS emissions from the Mill and there should be no changes in the surrounding airshed.

Odour prevention was a criterion used for selecting the effluent treatment technology. Indirect effluent cooling within the indirect air coolers, using subsurface air bubblers in the exterior process tanks, continuously removing solids to prevent septic conditions, and

enclosing the DAF units within the process building will all limit the potential for odour issues from the ETF.

Yellow lights were only applied to potential construction impacts and potential impacts related to mishaps, errors, and / or unforeseen events. Although yellow, those impacts are expected to be short-lived and implementation of the mitigation measures identified below will help reduce the potential impact.

4.4.4.4.3 Proposed Mitigation

The mitigation measures provided below should be undertaken by all Project personnel to ensure that the potential impacts to aesthetics are minimized.

- Heavy lift cranes should be lowered when no longer required. {Applicable to Stage II}
- Construction will normally be confined to Monday through Friday from 7 AM to 7 PM to limit the use of work site lighting; however, there may be instances when construction work is required during the evening or overnight and / or on weekends. {II}
- Construction lighting required for personnel safety during low-light conditions and evening hours should be confined to areas actively being worked, be downshielded, and extinguished when not in use. {II}
- Heavy equipment and vehicles should be turned off when not in use and / or when practical in order to limit the amount of exhaust and associated nuisance odours that have the potential to migrate offsite. {II, III}
- Heavy equipment exhaust systems should meet the recommended standards. {II, III}
- The plume abatement systems of the indirect air coolers should be in operation to limit the size and scale of visible water vapour plumes. {III}
- The indirect air coolers should be operated in a dry mode during winter months to eliminate visible water vapour plumes. {III}
- There is an option to construct a several meter high and wide berm in three sections along a largely unoccupied stretch of Milford Road to help mask the view of the infrastructure associated with the environmental treatment facility. {III}
- Permanent Project lighting will be limited to that necessary for Project personnel to perform their work safely and the lighting should be designed to minimize light trespass, which may include tilting or aiming luminaires away from neighbouring spaces, using light-emitting diode lights that provide targeted lighting levels, and controlling lights to turn off or dim when not necessary. {III}
- Odour abatement systems (*i.e.*, air scrubbers in the process building), or systems that help mitigate the generation of odours (*e.g.*, subsurface air blowers, solids removal system, *etc.*), should be maintained on appropriate schedules to limit the amount of odours generated. {III}
- IPP's protocol for handling odour complaints should be reviewed to ensure that measures exist for receiving, investigating, managing, and tracking odour complaints from the environmental treatment facility in a timely manner. {III}
- Mitigation measures developed for this Project should be adhered to in order to adequately address any potential impacts. {V}

4.4.4.4.4 Potential Post-Mitigation Residual Impacts

No residual and cumulative effects are likely to occur to local aesthetics over the duration of Project assuming the above mitigation measures are implemented.

4.4.4.5 Recreation and Tourism

4.4.4.5.1 Conceivable Impacts and Pathways

Activities and physical works that may occur throughout the Project that could potentially impact recreation and tourism are summarized in Table 61 along with their associated impact pathways. In the section that follows, the potential impacts are assessed in concert with the development of mitigation measures.

Table 61. The type of cause-effect relationships that are possible and the mechanisms by which stressors could ultimately lead to impacts on recreation and tourism during various activities associated with the proposed environmental treatment facility and water use reduction project at the Reversing Falls Mill in Saint John, New Brunswick.

Activity	Conceivable Impacts and Pathways
General construction	➤ Increase in local employment rate may translate to increased spending on local extra-curricular activities like recreation and tourism
Vegetation clearing	➤ Loss of natural features may subjectively affect the overall aesthetics of the area
Operation of heavy equipment	➤ Solitude of natural spaces may be affected by construction sound emissions
Pneumatic rock breaking activities	➤ Highly impulsive sounds (<i>e.g.</i> , pneumatic hammering) coupled with ground vibrations may be an annoyance and may affect the peacefulness of recreation and tourism spaces
Erection of tall structures	➤ Use of large cranes for hoisting may affect the scenic nature of the area
Safety lighting	➤ Light emitted from operational employee safety lights may affect use of the areas, particularly during the nighttime (<i>e.g.</i> , for star-gazing, <i>etc.</i>)

Because there are some tourist attractions within 5 km of the Project site (*i.e.*, refer to Figure 81) that are visited by locals and visitors to the region, the following potential impacts to recreation and tourism were assessed:

- site visitation and access;
- visitor numbers;
- economy and revenue generation; and
- scenic character.

4.4.4.5.2 Potential Impacts

Table 67 summarizes the potential impacts the Project may have on local recreation and tourism. Six yellow lights were applied to the Project and are particularly associated with mishaps, errors, and / or unforeseen events. The assessment also yielded four no change lights and two green lights.

4.4.4.5.3 Proposed Mitigation

It is difficult to develop mitigation measures related to tourist attractions that are not located on the Mill site because they are not under the proponent's control. Emergency response and contingency plans should be designed to prevent any major and / or sustained environmental damage on the Mill site in order to preserve what attracts people to the region.

The mitigation measures provided below should be undertaken by all Project personnel to ensure that the potential risks to recreation and tourism are minimized.

- Use of tall cranes during construction should be scheduled to complete the necessary hoisting activities within a coordinated window to limit their operational (*i.e.*, erection) period. {Applicable to Stage II}
- Construction work that has the potential to emit highly impulsive sounds (*e.g.*, pneumatic rock hammering, *etc.*) should be coordinated to be completed jointly and within the shortest period possible. {II}
- Lighting should be designed to minimize the amount of light that leaves the facility; down facing and shielded lighting should be employed to the maximum extent practicable. {III}
- Mitigation measures should be developed for this Project to minimize any potential impacts to recreation and tourism. {V}
- Emergency response and contingency plans should be designed to prevent any major and / or sustained environmental damage. {V}

4.4.4.5.4 Potential Post-Mitigation Residual Impacts

No residual impacts were identified.

4.4.4.6 Health and Safety

The proposed development has the potential to affect the health and safety of Project personnel, as well as the general public and visitors. As noted in Table 39, there is a potential for interaction during all stages of the Project. For this reason, health and safety was selected as a VEC.

4.4.4.6.1 Conceivable Impacts and Pathways

Activities and physical works that may occur during the Project and could impact health and safety are summarized in Table 62. Sound emissions are not included within the assessment of aesthetics as they were assessed as their own standalone VEC (*i.e.*, refer to Section 4.4.2.2).

Table 62. The type of cause-effect relationships that are possible and the mechanisms by which stressors could ultimately lead to impacts on health and safety during various stages associated with the proposed environmental treatment facility and water use reduction project at the Reversing Falls Mill in Saint John, New Brunswick.

Activity	Conceivable Impacts and Pathways
Construction and operation contractor and employee traffic	<ul style="list-style-type: none"> ➤ Increase in traffic volumes along local road networks may increase traffic accidents ➤ Conflicts with active transportation routes (<i>e.g.</i>, bikes on roadways, use of roadway shoulders as walking routes, <i>etc.</i>) ➤ Increase in traffic accidents
Transporting materials and equipment to and from the site	<ul style="list-style-type: none"> ➤ Increase in traffic volumes along local road networks may restrict traffic ➤ Traffic delays or disruptions to accommodate wide loads (<i>i.e.</i>, due to use of escorts or loads that are too wide for single lane transportation) may hamper roadway use ➤ Conflicts with active transportation routes (<i>e.g.</i>, bikes on roadways, use of roadway shoulders as walking routes, <i>etc.</i>) ➤ Increase in traffic accidents
General construction and operation	<ul style="list-style-type: none"> ➤ Workers will be involved in activities that will include the potential exposure to dust, loud sounds, and hazardous chemicals ➤ Workers will be exposed to conventional construction hazards related to such activities as hoisting, rigging, working around heavy equipment, confined spaces, welding, cutting, <i>etc.</i> ➤ Local residents may be exposed to loud sounds and ground vibrations from heavy construction equipment ➤ Local residents may be exposed to dust during site preparation activities and general construction traffic ➤ Light emitted from the Project may affect use of the areas, particularly during the nighttime (<i>e.g.</i>, for star-gazing, <i>etc.</i>)

Worker activities during operation will be governed by the Mill's Health and Safety Plan, which will outline a comprehensive set of operating procedures. Many of the activities currently undertaken at the Mill that have operational and safety plans associated with them will not change. Additional operation and safety plans will be created for any new activities associated with the Project.

Almost all workplace incidents resulting in bodily harm or death are attributed to mishaps, errors, and / or unforeseen events. Despite the rigorous mitigation measures implemented to prevent such incidents from happening, impacts may still result.

The following specific potential impacts pertaining to health and safety were assessed for the Project:

- occupational and personal hazards;
- airshed contamination;
- water contamination;
- solid waste and sanitary waste generation; and
- traffic hazards.

4.4.4.6.2 Potential Impacts

The impact assessment for health and safety is summarized in Table 68. Maintaining a safe work site is of paramount importance to IPP as described in Section 2.8.2.8. Therefore, green lights ($n = 10$) were given to the majority of potential impacts on the basis that the hazards associated with health and safety are well defined and understood and can be mitigated through IPP's rigorous health and safety protocols. Some potential impacts that may be present during construction, operation, or may occur as a result of mishaps, errors, and / or unforeseen events were given yellow lights ($n = 5$).

4.4.4.6.3 Proposed Mitigation

To mitigate any potential impact associated with health and safety, all Project personnel should be briefed on health and safety issues prior to implementing their tasks associated with the Project (e.g., during a site safety orientation session, toolbox meeting, tail gate meetings, etc.). They should be instructed on what Personal Protective Equipment (PPE) they must wear, what guards are to be in place, what measures are to be undertaken to protect themselves, their coworkers, and the general public, and how rules and regulations with respect to roadways and equipment must be followed at all times. In addition to this, safety areas such as first aid stations, fire extinguisher storage areas, eye wash stations, muster stations, and spill clean-up stations should be erected in various strategic locations around the Project site. Project personnel should be briefed on the general use, capabilities, and limitations of the mitigation measures.

Various safety procedures and protocols should be put in place, not only to protect those working on the site, but also used to protect the general public and visitors from any harm. The mitigation measures provided below should be undertaken by all Project personnel to ensure that the potential risks to Project personnel and public health and safety are minimized.

- All Project personnel should make occupational health and safety and public health and safety a primary objective in all their activities related to the Project. {Applicable to Stages II, III, and V}
- All Project personnel should be instructed on what personal protective equipment is required to be worn, what guards should be in place, what measures should be taken to protect other workers and the general public, and how rules and regulations with respect to the environment, roadways, and equipment should be strictly adhered to, with no exceptions. {II, III, and V}
- All Project personnel should be adequately trained to do their job so that they conform to the occupational health and safety standards and public health and safety standards. {II, III, and V}
- The Proponent should ensure that occupational health and safety standards and general public health and safety standards are part of the Project working environment and should ensure that Project personnel have appropriate personal protective equipment available to wear for the tasks they are performing. {II, III, and V}
- All hazardous materials (e.g., hydrocarbons, paints, solvents, polymers, acids, etc.) should be labelled appropriately and stored and used as per the manufacturer's recommendations. {II, III, and V}

- Project personnel working with hazardous chemicals should be trained appropriately for their safe use, handling, and storage, they should be provided with the appropriate personal protective equipment for their safe use, handling, and storage, and they should have access to the Material Safety Data Sheet information. {II, III, and V}
- Project personnel working at heights and / or within confined spaces and / or conducting diving activities should be trained appropriately for working under those conditions and should be provided with the appropriate personal protective equipment. {II, III, and V}
- Project personnel should immediately report any serious accident that results in lost time or property damage and those reports should be submitted promptly by the Proponent to the appropriate regulatory authority. {II, III, and V}
- A perimeter security fence should be erected to protect against non-authorized persons circulating within the Project site and appropriate signage should be erected on the fence (e.g., no trespassing, steep banks, high-voltage, etc.) at regular intervals along the security fences to warn the general public of potential risks from entering the Project site. {II, III, and V}
- All specialized work (e.g., electrical work, operating heavy equipment, refueling heavy equipment, diving operations, etc.) should only be completed by trained, competent, and / or certified / licensed professionals. {II, III, and V}
- Mitigation measures noted in the assessment of the Air Quality Valued Environmental Component should be implemented and followed. {II, III, and V}
- Mitigation measures noted in the assessment of the Surface Water Quantity and Quality Valued Environmental Component and the Groundwater Quantity and Quality Environmental Component should be implemented and followed. {II, III, and V}
- Mitigation measures noted in the assessment of the Transportation Network Valued Environmental Component should be implemented and followed. {II, III, and V}
- In the event of a spill and / or malfunction of equipment, the effluent should be directed to the diversion tank where it can be held and treated in an environmentally safe manner. {III}
- Emergency response and contingency plans should be designed to prevent any major and / or sustained environmental damage. {II, III, and V}

4.4.4.6.4 Potential Post-Mitigation Residual Impacts

No residual effects are anticipated, with respect to health and safety, during the construction and operation of the Project, if the above mitigation measures are implemented.

Table 63. Assessment of potential impacts on labour and economy of the proposed environmental treatment facility and water use reduction project at the Reversing Falls Mill in Saint John, New Brunswick.

Potential Impact	Stage II: Construction			Stage III: Operation and Maintenance			Stage V: Mishaps, Errors, and / or Unforeseen Events		
	Degree of Impact	Pathways	Mitigation	Degree of Impact	Pathways	Mitigation	Degree of Impact	Pathways	Mitigation
Employment / worker retention		1, 2	A, B		7, 8			12	E
Skills training		3, 4	C		9			12	E
Local spending		5	D		7, 10, 11	D		13, 14	E
Livelihood		6	D		7	D		12	E













PATHWAYS

- 1 – There will be an increase in employment for the local and regional construction labour market.
- 2 – The COVID-19 global pandemic has impacted the local, regional, provincial, national, and international economies. In Canada, unemployment rates have been high in transportation, service, and manufacturing industries as a consequence of the virus mitigation measures, such as social-distancing. As vaccination rates increase, the spread of the virus is being stemmed through safe practices, and as socio-economic support programs are beginning to wind down, there is a need for employment opportunities. Unemployment rates in the Saint John region are still high indicating the need for employment opportunities and this Project will help generate and promote economic development.
- 3 – Many of the Project construction jobs require skilled labour, such as surveyors, engineers, carpenters, heavy equipment operators, electricians, pipefitters, boilermakers, *etc.*
- 4 – Should other large-scale industrial projects be announced for the region, demand for skilled labour during peak construction periods may be too much for the local labour market to bear, which could put upward pressure on wages.
- 5 – The Project has an anticipated capital expenditure of \$150 million, which should result in considerable spending in the local and regional economy for many goods and services (*e.g.*, construction materials, construction equipment, restaurants and hospitality, income taxes, property taxes, *etc.*).
- 6 – This Project may allow some individuals in the local and regional area to maintain their livelihood as construction workers instead of having to look outside the region during periods of limited work. It is not expected that this Project will specifically lead people to launch a career in skilled trades.
- 7 – About five full-time permanent employees will be required to operate and maintain the environmental treatment facility generating wages and salaries that will be spent locally.
- 8 – Shutdowns will require additional skilled labour to maintain the specialized Project equipment.
- 9 – Operators will require routine training to ensure their skills are maintained.
- 10 – Goods and services, such as polymers and nutrients, will be required to operate and maintain the Project.
- 11 – Annual property taxes will be paid to the City of Saint John and provincial and federal taxes will also be generated annually.
- 12 – Errors, mishaps, and / or unforeseen events could result in a short-term or long-term stoppage in work.
- 13 – Depending on the error, mishap, and / or unforeseen event, third-party employment may be generated (*e.g.*, cleanup of a spill, *etc.*).
- 14 – Depending on the error, mishap, and / or unforeseen event, there may be a need for new or upgraded infrastructure.

MITIGATION

- A – Data indicate that there is ample room to grow employment in the local labour market (*i.e.*, unemployment rates remain at or above 8.5 %).
- B – Considering local unemployment rates, but subject to skills, availability, costs, and quality, hiring from the local workforce should be a priority for contractors to the maximum extent possible before going outside the region.
- C – Local and regional construction associations and labour unions may have to coordinate the quantity of available workers with the contractors should other large-scale industrial projects be announced for the region.
- D – The proponent should develop employment and procurement programs that promote opportunities for local workers and local businesses.
- E – Mitigation measures developed for this Project should be adhered to in order to adequately address any potential impacts in order to minimize the amount of lost work time.

Table 64. Assessment of potential impacts on archaeological and cultural features of the proposed environmental treatment facility and water use reduction project at the Reversing Falls Mill in Saint John, New Brunswick.

Potential Impact	Stage II: Construction			Stage III: Operation and Maintenance			Stage V: Mishaps, Errors, and / or Unforeseen Events		
	Degree of Impact	Pathways	Mitigation	Degree of Impact	Pathways	Mitigation	Degree of Impact	Pathways	Mitigation
Damage / destruction of archaeological sites and landmarks		1 to 10	A to G		1, 4, 9, 11, 12	E, F, G		1, 4, 7, 9, 12	A, B
Damage / destruction of cultural sites and landmarks		1 to 10	A to G		1, 4, 9, 11, 12	E, F, G		1, 4, 7, 9, 12	A, B
Conflict with ancestral remains		1 to 10	A to H		1, 4, 9, 11, 12	E to H		1, 4, 7, 9, 12	A, B, H
Conflict with cultural domains		1 to 10	A to H		1, 4, 9, 11, 12	E to H		1, 4, 7, 9, 12	A, B, H









PATHWAYS

- 1 – There are no known archaeological and / or cultural features within the Project footprint; however, accidental disruption / destruction of unknown buried resources is possible.
- 2 – Vegetation removal and ground disturbing exercises during clearing, grubbing, and site development can damage or destroy archaeological and / or cultural resources.
- 3 – Vandalism of the archaeological and cultural resources could occur after site preparation has begun.
- 4 – Vibrations from heavy equipment could cause damage to buried archaeological and / or cultural resources.
- 5 – Fracturing of rock through the use of pneumatic hammers can increase oxygen ingress into undisturbed layers, which could cause increased decay or corrosion of buried resources.
- 6 – Shock waves and vibrations could cause damage to buried resources.
- 7 – Ground spills of hydrocarbons during refueling operations (*i.e.*, gasoline and diesel) may allow hydrocarbons to infiltrate the ground and impact buried resources.
- 8 – Dewatering activities during footing, foundation, and pipeline construction may cause sediment layers to dry out, which could stimulate biodegradation of preserved resources.
- 9 – Hydrocarbon (*e.g.*, lubricating oils, gasoline, diesel, *etc.*) and chemical leaks (*e.g.*, polymers, acids, *etc.*) from the various treatment equipment may spill on to the ground and could contaminate surface waters and / or groundwater that eventually come in to contact with buried resources.
- 10 – Dust suppressants for controlling roadway dusts could come into contact with buried resources and result in damage.
- 11 – Salt for winter roadway maintenance could come into contact with buried resources and result in damage.
- 12 – Leaks or spills from effluent pipelines or effluent tanks could come into contact with buried resources and result in damage.

MITIGATION

- A – An archaeological resources protection plan, which may form part of the Project-specific environmental protection plan, should be developed and implemented prior to completing any onsite Project works.
- B – IPP will engage the Wolastoqey Nation in New Brunswick to train contractors and employees on their *Accidental Discovery of Archaeological Resources Protocol*.
- C – If deemed necessary, an archaeological testing regime should be conducted to determine the presence or absence of buried cultural resources within the footprint of the environmental treatment facility.
- D – Site security measures, in the form of a perimeter fence, should be erected prior to Project construction in order to limit entry to the site in order to protect any potential archaeological and cultural resources that may exist.
- E – Any archaeological or cultural feature discovered should be reported immediately to the appropriate Regulator(s) as per the New Brunswick *Heritage Conservation Act* [S.N.B. 2010, c. H-4.05].
- F – The Wolastoqey Nation in New Brunswick should be contacted immediately at 506.459.6341 if any archaeological or cultural resource is discovered as outlined in the *Accidental Discovery of Archaeological Resources Protocol*.
- G – If archaeological or cultural resources require removal to facilitate Project development, then excavation, recording, and reporting should occur for those features as per the New Brunswick *Heritage Conservation Act* [S.N.B. 2010, c. H-4.05].
- H - Should any human remains be discovered, the Saint John Police Force will be contacted to determine if the remains are an archaeological or cultural resources whereupon they will contact the appropriate authorities to have a licensed Resource Archaeologist examine the remains.

Table 65. Assessment of potential impacts on the transportation network of the proposed environmental treatment facility and water use reduction project at the Reversing Falls Mill in Saint John, New Brunswick.

Potential Impact	Stage II: Construction			Stage III: Operation and Maintenance			Stage V: Mishaps, Errors, and / or Unforeseen Events		
	Degree of Impact	Pathways	Mitigation	Degree of Impact	Pathways	Mitigation	Degree of Impact	Pathways	Mitigation
Traffic hazards		1, 2, 3	A to F		8, 9, 10	A to C, E, F		12	A to C, E, F
Damage to infrastructure		4, 5	F, G		4, 5, 11	F, G		4, 5, 11	F, G
Conflict with existing traffic		6, 7, 8	F, H		6	F		12	F, H

PATHWAYS

- 1 – There will be an increase in heavy equipment traffic along local roadways to deliver construction equipment and supplies.
- 2 – There will be an increase in personal vehicles entering and exiting the Mill site as it is projected that up to 130 contractor employees could be onsite during peak Project construction.
- 3 – There may be an increase in traffic accidents surrounding the Mill site on public roads as a result of increased traffic associated with the Project.
- 4 – There may be additional damage to road surfaces (*e.g.*, potholes, rutting, cracking, *etc.*) and associated infrastructure (*e.g.*, bridges, interchanges, *etc.*) due to wide and / or heavy loads or traffic volumes.
- 5 – Existing infrastructure is designed to standards capable of supporting the movement of heavy equipment to and from the Project site (*e.g.*, truck routes are designed for specific load limits, turning radii, *etc.*).
- 6 – There may be an increase in traffic volumes along local roadways.
- 7 – There may be a change in traffic volumes and patterns along local roadways (*i.e.*, peak traffic times may shift and / or be extended).
- 8 – There may be traffic delays or disruptions to accommodate wide loads (*i.e.*, due to escorts or loads that are too wide for single lane transportation).
- 9 – There will be a slight increase in the number of trucks going to and from the Mill site to deliver consumables required for the Project (*e.g.*, polymers, nutrients, *etc.*) and potentially for the transportation offsite of reclaimed fibre and solids for environmentally-responsible disposal.
- 10 – About five full-time permanent employees will be required to operate and maintain the environmental treatment facility (*i.e.*, one operator per shift), which will not perceptibly change the existing traffic patterns.
- 11 – Property tax revenue increases, which may result from this Project, would increase the amount of money available to the municipal and provincial governments for maintaining and improving public infrastructure.
- 12 – In the event of a major mishap, error, and / or unforeseen event, there may be a temporary increase in traffic until the impacts are mitigated. It would be expected that any increase in traffic would be short-lived.

MITIGATION

- A – All Project vehicles used on local roadways should be maintained according to provincial regulations with respect to licensing, insurance, and safety inspection.
- B – No vehicles associated with Project work (*i.e.*, personnel vehicles, construction vehicles, heavy equipment, *etc.*) should be allowed to park along roadways; parking should only occur in safe and identified locations.
- C – All Project personnel operating vehicles permitted on local roadways should obey the posted speed limits and other posted signs, such as weight restrictions.
- D – Carpooling of workers, while adhering to social distancing measures while under COVID-19 restrictions, should be encouraged during Project construction in order to reduce traffic volumes.
- E – Road traffic control measures (*e.g.*, use of flaggers, escort crews, *etc.*) should be used when transporting over-sized loads on public roadways using trained traffic personnel in accordance with the New Brunswick Department of Transportation and Infrastructure standards and practices.
- F – Any additional mitigation measures developed for this Project should be adhered to in order to adequately address any potential impacts.
- G – Heavy equipment haulers and shippers should adhere to weight restrictions and load limits as designated by the New Brunswick Department of Transportation and Infrastructure.
- H – To avoid traffic congestion, movement of heavy equipment to and materials to and from the Mill site during Project construction should be scheduled outside of normal peak traffic hours (*i.e.*, 7:30 AM to 8:30 AM and 4:30 PM to 5:30 PM Monday through Friday).

Table 66. Assessment of potential impacts on aesthetics of the proposed environmental treatment facility and water use reduction project at the Reversing Falls Mill in Saint John, New Brunswick.

Potential Impact	Stage II: Construction			Stage III: Operation and Maintenance			Stage V: Mishaps, Errors, and / or Unforeseen Events		
	Degree of Impact	Pathways	Mitigation	Degree of Impact	Pathways	Mitigation	Degree of Impact	Pathways	Mitigation
Visual		1, 2	A		7, 8	F, G, H		12	L
Light pollution		3, 4	B		9	I		12	L
Local compatibility		2, 5	A, B, C					12	L
Odour		6	D, E		10, 11	D, E, J, K		12	L

PATHWAYS

- 1 – Tall heavy lift cranes (*i.e.*, up to 40 m tall) may obstruct skyline views as the structures may be visible for many kilometers.
- 2 – Heavy equipment will be working in an area of the Mill site that has experienced little activity in recent years.
- 3 – Temporary construction lighting used during low-light and nighttime conditions may spill beyond the work areas and into adjacent commercial and residential areas.
- 4 – Construction activities at the site will conform with other developments undertaken at the Mill.
- 5 – Heavy industrial activity, including construction projects, have occurred at this site for at least 185 years. Residents living in adjacent residential neighbourhoods would be accustomed to this type of activity.
- 6 – Any odours generated through Project construction (*e.g.*, exhausts, *etc.*) should dissipate before reaching nearby residential receptors.
- 7 – The site topography has the advantage of concealing much of the environmental treatment facility from view; the hillside will be excavated to create benches for the Project infrastructure whereby only the top few meters will be visible from the nearest residential receptors along Milford Road.
- 8 – Depending on meteorological conditions (*e.g.*, temperature, wind direction and speed, humidity, *etc.*), water vapour plumes may be visible from the exhaust fans of the indirect air coolers and the exterior process tanks.
- 9 – Permanent Project lighting will be similar in quantity to the existing; however, the lighting will be of a newer technology that limits potential offsite impacts.
- 10 – Odour prevention during operation was a criterion used for selecting the environmental treatment facility (*e.g.*, indirect effluent cooling, subsurface air blowers, continuous solids removal, enclosing dissolved air flotation units in the process building, *etc.*); when the system is operating normally there should be little to no odour associated with the environmental treatment facility.
- 11 – There will be a limited amount of heavy equipment onsite required to complete maintenance on the environmental treatment facility during shutdowns.
- 12 – In the event of a major mishap, error, and / or unforeseen event, there may be short-lived impacts to aesthetics (*e.g.*, the erection of several tall cranes, the use of additional temporary lighting, the release of an unpleasant odour, *etc.*).

MITIGATION

- A – Heavy lift cranes should be lowered when no longer required.
- B – Construction will normally be confined to Monday through Friday from 7 AM to 7 PM to limit the use of work site lighting; however, there may be instances when construction work is required during the evening or overnight and / or on weekends.
- C – Construction lighting required for personnel safety during low-light conditions and evening hours should be confined to areas actively being worked, be downshilded, and extinguished when not in use.
- D – Heavy equipment and vehicles should be turned off when not in use and / or when practical in order to limit the amount of exhaust and associated nuisance odours that have the potential to migrate offsite.
- E – Heavy equipment exhaust systems should meet the recommended standards.
- F – The plume abatement systems of the indirect air coolers should be in operation to limit the size and scale of visible water vapour plumes.
- G – The indirect air coolers should be operated in a dry mode during winter months to eliminate visible water vapour plumes.
- H – There is an option to construct a several meter high and wide berm in three sections along a largely unoccupied stretch of Milford Road to help mask the view of the infrastructure associated with the environmental treatment facility.
- I – Permanent Project lighting will be limited to that necessary for Project personnel to perform their work safely and the lighting should be designed to minimize light trespass, which may include tilting or aiming luminaires away from neighbouring spaces, using light-emitting diode lights that provide targeted lighting levels, and controlling lights to turn off or dim when not necessary.
- J – Odour abatement systems (*i.e.*, air scrubbers in the process building), or systems that help mitigate the generation of odours (*e.g.*, subsurface air blowers, solids removal system, *etc.*), should be maintained on appropriate schedules to limit the amount of odours generated.
- K – IPP's protocol for handling odour complaints should be reviewed to ensure that measures exist for receiving, investigating, managing, and tracking odour complaints from the environmental treatment facility in a timely manner.
- L – Mitigation measures developed for this Project should be adhered to in order to adequately address any potential impacts.

Table 67. Assessment of potential impacts on recreation and tourism of the proposed environmental treatment facility and water use reduction project at the Reversing Falls Mill in Saint John, New Brunswick.

Potential Impact	Stage II: Construction			Stage III: Operation and Maintenance			Stage V: Mishaps, Errors, and / or Unforeseen Events		
	Degree of Impact	Pathways	Mitigation	Degree of Impact	Pathways	Mitigation	Degree of Impact	Pathways	Mitigation
Site visitation / access	⊖	1		⊖	1		⚠	9	D, E
Visitor numbers	⊖	1		⊖	1		⚠	9	D, E
Economy and revenue generation	⊕	2		⊕	2		⚠	9	D, E
Scenic character	⚠	3 to 6	A, B	⚠	7, 8	C	⚠	9	D, E

PATHWAYS

- 1 – The Reversing Falls Mill site is a private industrial site and there is no public access.
- 2 – Increasing local employment may translate to increased spending on local extra-curricular activities like recreation and tourism.
- 3 – Loss of some of the limited natural features remaining on the Mill site may subjectively affect the overall aesthetics of the area.
- 4 – Operation of heavy equipment can emit loud sounds (*e.g.*, general operation and back up alarms), which can be an annoyance to users of nearby recreation and tourist sites.
- 5 – Additional tall structures at the Mill during construction (*i.e.*, cranes) may affect the scenic nature of the area, but people are still going to visit the top local attractions such as the renowned Reversing Falls at Fallsview Park on the opposite side of the Saint John River from the Mill.
- 6 – Highly impulsive sounds (*e.g.*, pneumatic rock hammering, *etc.*) coupled with ground vibrations may be an annoyance and may affect the peacefulness of nearby recreation and tourism spaces.
- 7 – Once Project construction is complete, the new buildings and infrastructure will blend into the industrial landscape.
- 8 – Additional light emitted from the environmental treatment facility may increase light levels during the nighttime, which could affect low-light activities such as star-gazing.
- 9 – Depending on the type / degree of event, there may be a possibility that access to one of the immediately adjacent tourist sites (*e.g.*, Fallsview Park, Wolastoq Park, *etc.*) could be restricted for a short period of time, which could reduce the number of visitors.

MITIGATION

- A – Use of tall cranes during construction should be scheduled to complete the necessary hoisting activities within a coordinated window to limit their operational (*i.e.*, erection) period.
- B – Construction work that has the potential to emit highly impulsive sounds (*e.g.*, pneumatic rock hammering, *etc.*) should be coordinated to be completed jointly and within the shortest period possible.
- C – Lighting should be designed to minimize the amount of light that leaves the facility; down facing and shielded lighting should be employed to the maximum extent practicable.
- D – Mitigation measures should be developed for this Project to minimize any potential impacts to recreation and tourism.
- E – Emergency response and contingency plans should be designed to prevent any major and / or sustained environmental damage.

Table 68. Assessment of potential impacts on health and safety of the proposed environmental treatment facility and water use reduction project at the Reversing Falls Mill in Saint John, New Brunswick.

Potential Impact	Stage II: Construction			Stage III: Operation and Maintenance			Stage V: Mishaps, Errors, and / or Unforeseen Events		
	Degree of Impact	Pathways	Mitigation	Degree of Impact	Pathways	Mitigation	Degree of Impact	Pathways	Mitigation
Occupational and personal hazards		1 to 4	A to J		1 to 4, 9	A to J		1 to 4, 9	A to J, O
Airshed contamination		5	A to D, K		10	B, K		10	B, K, O
Water contamination		6	F, J, L		6, 11	F, J, L, N		6, 11	F, J, L, O
Solid waste and sanitary waste generation		7	B		7	B		7	B, O
Traffic hazards		8	B, M		8, 9	B, M		8, 9	B, M, O

PATHWAYS

1 – The implementation of health and safety protocols is a fundamental component to the operation of the Mill and during maintenance upgrades and shutdowns. If there is not currently a developed health and safety protocol for a specific task, it is expected that one will be developed to protect the health and safety of Project personnel.

2 – Workers may be involved in activities that will include the potential exposure to dust, loud sounds, hazardous chemicals (*e.g.*, hydrocarbons, paints, solvents, polymers, acids, *etc.*), excavations, working at heights, working in confined spaces, working around tanks filled with effluent, diving during construction of the cooling water intake line and potentially during operations, *etc.*

3 – Accidents could cause personal injury (*e.g.*, if back up alarms are not used, if inattentiveness occurs during operation, *etc.*) and infrastructure damage.

4 – The general public could be harmed if adequate precautions are not taken to keep them from accessing the Project site during construction and keeping them away from hazards (*e.g.*, operation of heavy equipment, *etc.*) and during operations and protecting them from dangerous situations (*e.g.*, steep banks, tanks filled with effluent, *etc.*).

5 – As noted in the Air Quality Valued Environmental Component Impact Assessment table, there is expected to be a moderate, though localized, impact on air quality during Project construction primarily as a result of the increased operation of heavy equipment emitting pollutants to the local airshed.

6 – Spills of hazardous chemicals (*e.g.*, hydrocarbons, paints, solvents, *etc.*) could cause contamination.

7 – Sanitary and solid wastes generated during Project construction and operation and maintenance activities should be handled appropriately (*e.g.*, sanitary waste should be collected and disposed of using a licensed wastewater hauler, approved construction debris and operation and maintenance waste will be sent to the Crane Mountain Landfill, collected fibre and solids will be sent to the onsite biomass boiler or a compost facility, *etc.*).

8 – As noted in the Transportation Network Valued Environmental Component Impact Assessment table, there is expected to be an increase in potential traffic hazards throughout all Project stages, but it will be the greatest during construction.

9 – There will still be risks during operation and maintenance, but they will be considerably lower than construction and there will be a limited compliment of employees assigned to the environmental treatment facility (*i.e.*, ~ five).

10 – As noted in the Air Quality Valued Environmental Component Impact Assessment table, there is expected to be minimal impact on air quality during Project operations considering the mitigation measures that have been designed in to the Project (*e.g.*, closed piping within the indirect air coolers, installing the dissolved air flotation tanks within an enclosed building, *etc.*).

11 – A release of effluent outside of the parameters noted in the Pulp and Paper Effluent Regulations could have an impact on the receiving environment (*i.e.*, Saint John River) and waters downstream (*i.e.*, Saint John Harbour, and Bay of Fundy).

12 – All mishaps, errors, and / or unforeseen events by their nature pose potential impacts to health and safety of Project personnel.

MITIGATION

A – All Project personnel should make occupational health and safety and public health and safety a primary objective in all their activities related to the Project.

B – All Project personnel should be instructed on what personal protective equipment is required to be worn, what guards should be in place, what measures should be taken to protect other workers and the general public, and how rules and regulations with respect to the environment, roadways, and equipment should be strictly adhered to, with no exceptions.

C – All Project personnel should be adequately trained to do their job so that they conform to the occupational health and safety standards and public health and safety standards.

D – The Proponent should ensure that occupational health and safety standards and general public health and safety standards are part of the Project working environment and should ensure that Project personnel have appropriate personal protective equipment available to wear for the tasks they are performing.

E – All hazardous materials (*e.g.*, hydrocarbons, paints, solvents, polymers, acids, *etc.*) should be labelled appropriately and stored and used as per the manufacturer's recommendations.

F – Project personnel working with hazardous chemicals should be trained appropriately for their safe use, handling, and storage, they should be provided with the appropriate personal protective equipment for their safe use, handling, and storage, and they should have access to the Material Safety Data Sheet information.

G – Project personnel working at heights and / or within confined spaces and / or conducting diving activities should be trained appropriately for working under those conditions and should be provided with the appropriate personal protective equipment.

H – Project personnel should immediately report any serious accident that results in lost time or property damage and those reports should be submitted promptly by the Proponent to the appropriate regulatory authority.

I – A perimeter security fence should be erected to protect against non-authorized persons circulating within the Project site and appropriate signage should be erected on the fence (*e.g.*, no trespassing, steep banks, high-voltage, *etc.*) at regular intervals along the security fences to warn the general public of potential risks from entering the Project site.

J – All specialized work (*e.g.*, electrical work, operating heavy equipment, refueling heavy equipment, diving operations, *etc.*) should only be completed by trained, competent, and / or certified / licensed professionals.

K – Mitigation measures noted in the assessment of the Air Quality Valued Environmental Component should be implemented and followed.

L – Mitigation measures noted in the assessment of the Surface Water Quantity and Quality Valued Environmental Component and the Groundwater Quantity and Quality Environmental Component should be implemented and followed.

M – Mitigation measures noted in the assessment of the Transportation Network Valued Environmental Component should be implemented and followed.

N – In the event of a spill and / or malfunction of equipment, the effluent should be directed to the diversion tank where it can be held and treated in an environmentally safe manner.

O – Emergency response and contingency plans should be designed to prevent any major and / or sustained environmental damage.

4.4.5 Summary of Potential Environmental Impacts

IPP is committed to environmental excellence and continually explores innovative ways to reduce their environmental footprint. The Mill produces high quality products in an environmentally sustainable and socially responsible manner by operating under stringent environmental policies. Employees are committed to:

- continually seeking to understand operational impacts on the air, water, soil, forest ecosystem, and local communities;
- actively working to continuously improve our environmental performance;
- meeting or exceeding relevant environmental legislation and regulations;
- meeting the requirements of organizations and associations to which we belong;
- educating other employees and contractors about environmental concerns, their environmental responsibilities, and corporate policies and best practices;
- encouraging other employees and contractors be environmental advocates; and
- cooperating with efforts to raise public awareness about environmental issues.

As described above, 12 VECs were assessed for potential impacts to the environment by the proposed Project. An overall VEC impact assessment summary is provided in Table 69. The results indicate that in many instances, there are no changes anticipated as a result of this Project.

Table 69. Summary of the potential impacts of the proposed environmental treatment facility and water use reduction project at the Reversing Falls Mill in Saint John, New Brunswick on selected valued environmental components.

VEC	Number of Lights For Stage II / III / V				Overall VEC Impact Assessment*
	Green	Yellow	Red	No Change (Blue)	
PHYSIO-CHEMICAL ENVIRONMENT					
Air quality	0 / 1 / 1	5 / 6 / 5	0 / 0 / 0	2 / 0 / 1	
Sound emissions	0 / 0 / 4	4 / 0 / 0	0 / 0 / 0	0 / 4 / 0	
Surface water quality and quantity	2 / 5 / 1	3 / 0 / 4	0 / 0 / 0	0 / 0 / 0	
Groundwater quality and quantity	0 / 3 / 0	4 / 0 / 2	0 / 0 / 0	1 / 2 / 3	
BIOLOGICAL ENVIRONMENT					
Terrestrial flora and fauna	0 / 2 / 0	3 / 1 / 3	0 / 0 / 0	3 / 3 / 3	
Aquatic flora and fauna	3 / 3 / 0	0 / 1 / 4	0 / 0 / 0	4 / 3 / 3	
SOCIO-ECONOMIC ENVIRONMENT					
Labour and economy	4 / 4 / 3	0 / 0 / 1	0 / 0 / 0	0 / 0 / 0	
Transportation network	3 / 3 / 3	0 / 0 / 0	0 / 0 / 0	0 / 0 / 0	
Archaeological & cultural resources	0 / 4 / 0	4 / 0 / 4	0 / 0 / 0	0 / 0 / 0	
Aesthetics	1 / 3 / 0	3 / 0 / 4	0 / 0 / 0	0 / 1 / 0	
Recreation and tourism	1 / 1 / 0	1 / 1 / 4	0 / 0 / 0	2 / 2 / 0	
Health and safety	3 / 4 / 3	2 / 1 / 2	0 / 0 / 0	0 / 0 / 0	
TOTALS	65	72	0	37	

NOTES: *No change lights are excluded from the determination of the overall VEC impact; the coloured light that received the greatest number of assignments in the environmental assessment determines the ultimate VEC impact

All told, 174 specific possible impacts were assessed (Table 69). Of those, 21 % ($n = 37$) yielded no change lights, 38 % ($n = 65$) were assigned green lights, and 41 % ($n = 72$) were given yellow lights. No red lights or were assigned to any of the potential impacts (*i.e.*, not favourable or major impacts). The ultimate Project impact assessment produced a yellow light (*i.e.*, based on the summation of all possible impacts for the 12 VECs). The proposed Project is expected to have little to no impact on the environment considering the comprehensive mitigation measures developed. Therefore, the Project should proceed as detailed within this EIA document.

Although the ultimate VEC yielded a yellow light, the majority of the yellow lights were applied to potential impacts during Stage II and / or Stage V (Table 69). **There are very few operational impacts associated with this Project.**

4.5 POTENTIAL ENVIRONMENT IMPACTS ON THE PROJECT

As part of the NBDELG's EIA process, the environment's impact on a project should also be assessed (*e.g.*, seasonal flooding and extreme events, such as maximum precipitation, wind, and climate change scenarios, which may be pertinent to long-term facilities). No government agency provides specific guidance on how to properly assess the impacts of the environment on a project, but instead it is left up to the proponent. Several impacts of the environment on the proposed Project are considered here including: temperature; precipitation; wind; wet and dry acid deposition; seismic events; and sea level rise. One particular theme of interest in assessing the impact of the environment on a project is climate change.

4.5.1 Notes on Climate Change

The international scientific community generally agrees that climate change is occurring and that the impacts are currently being felt globally [Warren and Lulham, 2021]. Since the 1950s, observations have been made with regards to the warming of the atmosphere, the warming of the ocean, the decrease in the amounts and duration of snow and ice cover, the increase in sea level, and the increased concentrations of GHGs present in the atmosphere. Changes observed in recent years are unprecedented when compared with historical data over similar timeframes in the past [IPCC, 2021]. For example, the period between 1983 and 2012 in the northern hemisphere was likely the warmest 20 year period of the last 1 400 years [IPCC, 2013], and the global surface temperature has increased faster since 1970 than in any other 50 year period or the last 2 000 years [IPCC, 2021]. As the phenomena of climate change continues, the effects are predicted to increase at an accelerating rate.

The Intergovernmental Panel on Climate Change (IPCC), through climate modeling scenarios, estimates that mean global surface temperatures are likely to increase 1.0 °C to 5.7 °C during the twenty-first century [IPCC, 2021], depending on the GHG emission scenario used. Warming is anticipated to be most prominent over land and at high northern latitudes, which means that Canada, because it is a high latitude country, is expected to have more pronounced warming [Bruce *et al.*, 2000]. Although temperatures are predicted to increase over time, seasonal variations are still expected. According to the IPCC [2013], recent climate warming has already shown to have had an effect on terrestrial biological systems such as the timing of spring events (*e.g.*, bird migration and egg laying, leaf unfolding, northern shifts in the habitable ranges of various flora and fauna, *etc.*).

The rate of sea level rise since 1900 has been larger than over any preceding century during the previous three millennia. Sea levels increased by 0.15 m to 0.25 m between 1901 and 2018 and a 0.26 m to 0.82 m increase in global mean sea level is predicted by the year 2100 [IPCC, 2013 and 2021]. Rising sea levels and the increased rate in change can be attributed to thermal expansion resulting from an increase in ocean temperatures and a loss of frozen ice mass from glaciers and ice sheets. Water levels along the southeastern coast of New Brunswick could increase by 50 cm to 70 cm by the end of this century [Parkes et. al., 2006].

Changes to climate will not be homogenous, but instead vary regionally. In Atlantic Canada, inland areas may be subject to drier summers where increased evaporation of water may exceed increased precipitation. Coastal regions may be subjected to frequent flooding caused by a rising sea coupled with an anticipated increase of high intensity weather systems [Vasseur and Catto, 2008]. Zweirs and Kharn [1998] speculate that the most acute effects under a changing climate may be the increased intensity and frequency of extreme events, and in particular precipitation events.

Bruce et al. [2000] predict climate changes for Atlantic Canada if a doubled CO₂ atmosphere is attained by 2050. Under a doubled CO₂ atmosphere, summer temperatures are likely to be 4 °C warmer than current, while winter temperatures may increase by about 6 °C. Vasseur and Catto, [2008] estimate that by 2050 temperatures in Atlantic Canada will increase by 2 °C to 4 °C during the summer and 1.5 °C to 6 °C during the winter. For Saint John in 2080, the maximum and minimum temperatures are expected to increase by 3.9 °C to 4.2 °C and 3.8 °C to 4.2 °C, respectively [Lines et. al., 2006].

Precipitation amounts under a doubled CO₂ atmosphere may increase by 20 % in the winter, and although unpredictable, summer precipitation amounts are also expected to increase. Studies by Lewis [1997] show that precipitation in Atlantic Canada between 1948 and 1995 increased by about 10 %. Predictions by Lines et. al., [2006] suggest that by 2080, precipitation for Saint John could increase by as much as 12 % in the winter and 35 % in the summer. Extreme precipitation events are expected, according to Zweirs and Kharn [1998], to increase and may result in decreasing return periods by half (i.e., a 100 year event will become a 50 year event under a doubled CO₂ environment).

The following guidance was offered by the *Canadian Environmental Assessment Agency* [2003] for assessing climate change:

The objective [of the guidance document] is to help practitioners assess, reduce, and manage the adverse impacts that climate change may have on projects and ensure that these impacts will not pose a risk to the public or the environment. The consideration of climate change impacts on a project is a component of the standard EA practice of considering possible changes to a project caused by the environment. The consideration of climate change impacts in EA should reflect regional variations in climate and environment, and jurisdictional practices.

Design engineers and architects generally follow specific guidelines with respect to design criteria. Those design criteria consider the environmental effects of climate change and the potential cumulative effects on built structures (e.g., increased streamflow through a culvert, increased snow loads on a roof, etc.). Engineers will account for impacts of

climate change on the proposed Project in their design. Mitigation of potential effects of the environment on the proposed Project are also inherent in the planning (*i.e.*, the EIA document), construction (*i.e.*, environmental protection / management plans), and planned operation of the Project (*i.e.*, capture and handling of surface water runoff).

The information contained in this section of the document provides information on how the environment may affect the Project. A considerable adverse effect of the environment on the proposed Project is considered one that would result in:

- a long-term interruption in schedule (*i.e.*, a construction season) or in service (*i.e.*, several days);
- damage to infrastructure that is not economically feasible to repair (*i.e.*, > 150 % of the total original cost); and / or
- causes a considerable negative effect on an established VEC for the Project as per the criteria established for that VEC.

Many planning, design, and construction strategies are available to minimize the potential effects of the environment on the Project so that risk of serious damage to infrastructure, human health, or interruption of service can be reduced to acceptable levels. The National Codes of Canada, which will be strictly adhered to for this Project, identify many codes and standards that address environmental considerations during all aspects of a project.

The scope of the assessment of the environment on the Project is limited by spatial and temporal boundaries. Analysis is done only for inside the Project boundaries and all seasons were analyzed. Consideration was given to construction, operation, maintenance, and errors, mishaps, and / or unforeseen events.

4.5.2 Notes on Extreme Weather

The frequency and severity of extreme weather is on the rise globally (Figure 99) and it appears to be a product of climate change [Carey, 2012]. The number of extraordinary severe floods, storms, and other weather related events that have occurred during the previous few decades seems to suggest that extreme weather events are becoming more common [Francis and Hengeveld, 1998]. Over the past few decades in Atlantic Canada, the most-costly extreme weather events have been hurricanes [ICLR, 2012].

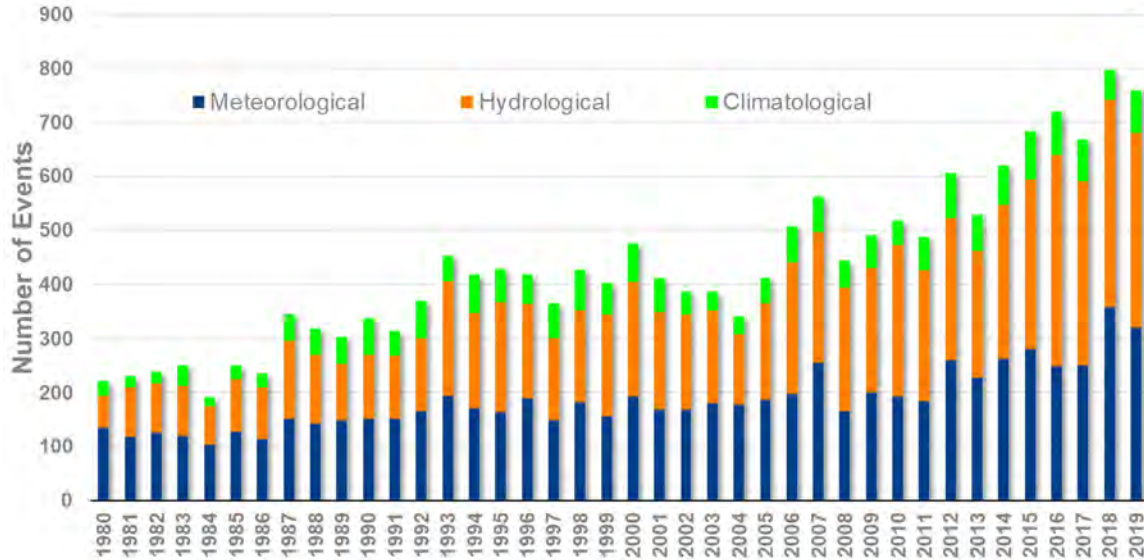

Figure 99. Global natural loss extreme weather related events between 1980 and 2019 with at least one fatality and / or produced normalized losses over the threshold assigned by the World Bank [NatCatSERVICE, 2019].

Public Safety Canada (PSC) maintains the Canadian Disaster Database (CDD). The CDD contains detailed disaster information for 83 natural disasters that have occurred in New Brunswick since 1900. About 45 % of those natural disasters have occurred in the past 25 years. The events are broken down as shown in Figure 100. The most-costly event on record was the 1998 Ice Storm (*n.b.*, the event extended across Ontario, Quebec, and Atlantic Canada).

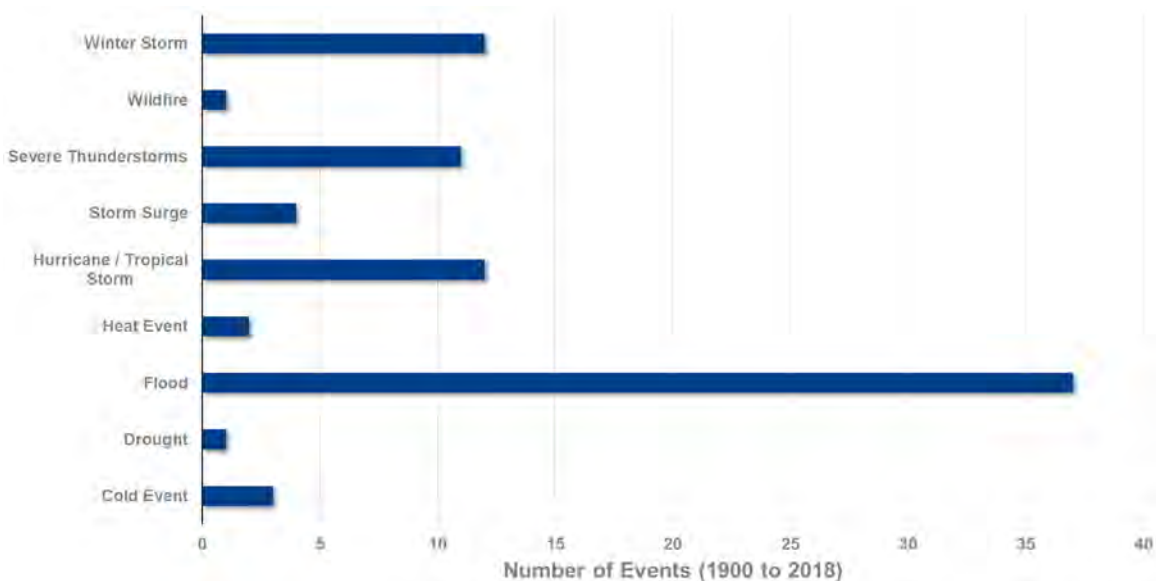

Figure 100. Characterization of the 83 natural disasters for New Brunswick between 1900 and 2019 as recorded in the Canadian Disaster Database [PSC, 2019].

4.5.3 Temperature

Increased temperatures from a changing climate could increase the frequency and intensity of thunderstorms. Those thunderstorms could be coupled with more intense precipitation and / or hail. Electrical power outages are often experienced during severe thunderstorms.

In Atlantic Canada, increased precipitation in the winter, coupled with expected elevated temperatures, may result in the increased frequency of rain on snow events resulting in larger volumes of precipitation being discharged as runoff and a smaller percentage of precipitation infiltrating the surface and recharging groundwater systems [Vasseur and Catto, 2008]. This phenomenon also increases the risk of flooding due to the reduced lag time associated with runoff entering watercourses versus groundwater infiltrating watercourses after precipitation events. Contamination of flood waters may pose further damage to the environment, should they come into contact with sewage, domestic or industrial waste, or agricultural pesticides and fertilizers [Vasseur and Catto, 2008].

Increased temperatures from a changing climate will likely result in increased temperatures of Spruce Lake and the Saint John River, which are important heat sinks for the Project. The increase in temperature from climate change could affect the operation of Project equipment, such as the heat exchangers and the indirect air coolers (e.g., additional heat exchangers may be required to ensure temperatures meet regulations prior to discharge to the receiving water body, etc.).

Temperatures under a changing climate present several concerns to the Project, which are listed in Table 70. Measures are presented to mitigate the identified concerns.

Table 70. Potential concerns and mitigation measures of increased temperature under a changing climate on the proposed environmental treatment facility and water use reduction project at the Reversing Falls Mill in Saint John, New Brunswick.

Event	Concern	Mitigation
<u>Extreme heat or cold events</u>		
	Unsafe work conditions	<ul style="list-style-type: none"> ➤ Work should be halted when extreme temperatures cause unsafe working conditions ➤ Disruption of Project activities and delays during construction may be avoided by scheduling tasks that require optimal weather conditions to occur when weather conditions are favourable
<u>Electrical storms</u>		
	Loss of electrical power	<ul style="list-style-type: none"> ➤ All permanent Project electrical equipment should be equipped with back-up power to maintain operations throughout a power outage ➤ All permanent Project electrical equipment should be properly grounded
<u>Rain on snow events</u>		
	Localized flooding	<ul style="list-style-type: none"> ➤ As much as practicable, the proponent should develop softscapes in order to absorb these events ➤ A surface water management program should be part of the overall landscape design for the Project site

Event	Concern	Mitigation
		<ul style="list-style-type: none"> ➤ Throughout the Project development, appropriately engineered drainage measures, as part of the erosion and sedimentation control plan, should be implemented ➤ Structures that could be impacted by flooding should be located well above (<i>i.e.</i>, > 1 m) the predicted high-high water mark of the Saint John River ➤ Permanent drainage infrastructure should be designed considering the largest possible storm event (<i>i.e.</i>, 1 in 100 year 24 hour event)
	Loss of electrical power	<ul style="list-style-type: none"> ➤ All permanent Project electrical equipment should be equipped with back-up power to maintain operations throughout a power outage
<u>Changing thermal regimes</u>		
	Operation of temperature moderating equipment	<ul style="list-style-type: none"> ➤ Design engineers should account for the variation in the minimum, average, and maximum annual air and water temperatures when specifying the equipment for temperature moderation

4.5.4 Precipitation

Occasionally, tropical storms and hurricanes pass through the region bringing with them extreme precipitation (*n.b.*, the Atlantic hurricane season extends annually from 1 June to 30 November). Heavy bursts of rain and hail during thunderstorms are typically short-lived and occur on an infrequent basis in the Saint John region. Heavy snowfalls are common in New Brunswick, but they do not typically cause any considerable impacts. As noted above, climate change is expected to increase the amount of annual precipitation in the Saint John region.

One impact being realized locally as a result of increased winter precipitation is an increase in flooding during the spring freshet. In 2018, the lower Saint John River basin experienced unprecedented flooding (*i.e.*, refer to Section 3.1.5). Those conditions were almost repeated in 2019. During the unprecedented flooding of May 2018, some portions of the Mill site were flooded. In spring 2020, IPP began a project to permanently raise the elevation of the river banks surrounding the low-lying areas of the Mill to protect against future flooding.

Design engineers will use appropriate codes and standards for planning the Project, which has an estimated operational lifespan of 50 years. Best design practices dictate that those professionals consider a changing climate. Because potential impacts are being planned for in the design, considerable impacts are not expected to occur. As an assessment tool, potential precipitation events that could have an impact on the Project are listed in Table 71. Also listed are potential concerns and mitigation measures.

Table 71. Potential concerns and mitigation measures of increased precipitation under a changing climate on the proposed environmental treatment facility and water use reduction project at the Reversing Falls Mill in Saint John, New Brunswick.

Event	Concern	Mitigation
<u>Extreme (> 50 mm) precipitation events</u>		
	Unsafe work conditions	<ul style="list-style-type: none"> ➤ Work should be halted when extreme precipitation causes unsafe working conditions ➤ Disruption of Project activities and delays during construction may be avoided by scheduling tasks that require optimal weather conditions to occur when weather conditions are favourable
	Unsafe travel conditions	<ul style="list-style-type: none"> ➤ Workers, the public, and visitors should use their own discretion
	Localized flooding	<ul style="list-style-type: none"> ➤ As much as practicable, the proponent should develop softscapes in order to absorb these events ➤ A surface water management program, which includes an erosion and sedimentation control plan during construction, should be part of the overall landscape design for the Project site ➤ Throughout the Project development, appropriately engineered drainage measures, as part of the erosion and sedimentation control plan, should be implemented ➤ Structures that could be impacted by flooding should be located well above (<i>i.e.</i>, > 1 m) ground-level and / or the predicted high-high water mark of the Saint John River ➤ Permanent drainage infrastructure should be designed considering the largest possible storm event (<i>i.e.</i>, 1 in 100 year 24 hour event)
	Increased overland flow	<ul style="list-style-type: none"> ➤ As much as practicable, the proponent should develop green spaces in order to absorb these events ➤ Landscaping could help limit overland flow
	Increased insurance costs	<ul style="list-style-type: none"> ➤ Flooding mitigation should be implemented to minimize risk of damage and associated insurance claims
	Increased capture volume of precipitation (<i>i.e.</i> , capture by open ETF tanks)	<ul style="list-style-type: none"> ➤ Design engineers should account for the increased volume of captured precipitation with respect to the treatment of effluent (<i>e.g.</i>, tank and pump sizing, <i>etc.</i>)
	Loss of electrical power	<ul style="list-style-type: none"> ➤ All permanent Project electrical equipment should be equipped with back-up power to maintain operations throughout a power outage
<u>High frequency and high intensity precipitation events</u>		
	Increased erosion	<ul style="list-style-type: none"> ➤ Appropriately engineered landscaped areas should offset increased erosion posed by these events ➤ Erosion and sedimentation control structures should be installed during construction to limit potential impacts
	Localized flooding	<ul style="list-style-type: none"> ➤ As much as practicable, the proponent should develop softscapes in order to absorb these events ➤ A surface water management program should be part of the overall landscape design for the Project site ➤ Throughout the Project development, appropriately engineered drainage measures, as part of the erosion and sedimentation control plan, should be implemented

Event	Concern	Mitigation
		<ul style="list-style-type: none"> ➤ Structures that could be impacted by flooding should be located well above (<i>i.e.</i>, > 1 m) the predicted high-high water mark of the Saint John River ➤ Permanent drainage infrastructure should be designed considering the largest possible storm event (<i>i.e.</i>, 1 in 100 year 24 hour event)
	Increased overland flow	<ul style="list-style-type: none"> ➤ As much as practicable, the proponent should develop green spaces in order to absorb these events ➤ Landscaping could help limit overland flow
	Loss of electrical power	<ul style="list-style-type: none"> ➤ All permanent Project electrical equipment should be equipped with back-up power to maintain operations throughout a power outage

Heavy snowfalls

	Unsafe work conditions	<ul style="list-style-type: none"> ➤ Work should be halted when extreme precipitation causes unsafe working conditions ➤ Disruption of Project activities and delays during construction may be avoided by scheduling tasks that require optimal weather conditions to occur when weather conditions are favourable
	Unsafe travel conditions	<ul style="list-style-type: none"> ➤ Workers, residents, and visitors should use their own discretion
	Increased stress and strain on structures through snow loads	<ul style="list-style-type: none"> ➤ Engineers and architects should account for snow loads in the design of the structures to accommodate increased potential snow loads under a changing climate throughout the Project's lifespan ➤ Materials specified for the Project should be in compliance with the appropriate standards and codes (<i>n.b.</i>, the National Building Code of Canada provides for factors of safety to account for possible extreme weather, including allowances for future increased frequency and / or severity of precipitation events that could arise from climate change)
	Localized flooding during spring melt	<ul style="list-style-type: none"> ➤ As much as practicable, the proponent should develop softscapes in order to absorb these events ➤ A surface water management program should be part of the overall landscape design for the Project site ➤ Throughout the Project development, appropriately engineered drainage measures, as part of the erosion and sedimentation control plan, should be implemented ➤ Structures that could be impacted by flooding should be located well above (<i>i.e.</i>, > 1 m) the predicted high-high water mark of the Saint John River
	Loss of electrical power	<ul style="list-style-type: none"> ➤ All permanent Project electrical equipment should be equipped with back-up power to maintain operations throughout a power outage

Increased fog

	Unsafe work conditions	<ul style="list-style-type: none"> ➤ Work should be halted when extreme precipitation causes unsafe working conditions ➤ Disruption of Project activities and delays during construction may be avoided by scheduling tasks that require optimal weather conditions to occur when weather conditions are favourable
	Unsafe travel conditions	<ul style="list-style-type: none"> ➤ Workers, the public, and visitors should use their own discretion

4.5.5 Winds

Winds are weaker at the ground surface compared to higher up in the atmosphere because of increased resistance afforded by vegetation and structures [Henry and Heinke, 1996; Lutgens and Tarbuck, 2001]. No predictions that the authors are aware of have been made with respect to wind directions and speeds under a changing climate for Atlantic Canada; however, it is likely that winds could increase / decrease in speed as a result of changing temperature patterns. For example, there has been an increase in the number of named storms (*i.e.*, once storms develop and sustained wind speeds > 63 km · hr⁻¹) in the Atlantic region since 1850 (Figure 101).

The following is a list of some concerns related to increased wind speeds that could pose an impact to this Project along with mitigation measures:

- unsafe work conditions:
 - work should be halted when high winds cause unsafe working conditions, such as flying objects and debris, reduced visibility, personal instability, and equipment instability; and
 - disruption of Project activities and delays during construction can be avoided by scheduling tasks that require optimal weather conditions to occur when weather conditions are favourable.
- increased wind erosion:
 - during construction, stockpiles should be covered with tarps;
 - easily erodible permanent surfaces should be landscaped or hardscaped;
- increased stress and strain on structures:
 - materials specified for the Project should be in compliance with the appropriate standards and codes (*n.b.*, the National Building Code of Canada provides for factors of safety to account for possible extreme weather, including allowances for future increased frequency and / or severity of wind events that could arise from climate change);
 - buildings and structures should be designed to withstand wind extremes throughout the Project's lifespan; and
 - structural engineers should account for increased wind stress and strain in their design to accommodate potential increased winds under a changing climate; and
- increased blowing and drifting snow:
 - landscaped buffers between Project infrastructure and adjacent properties could create a wind / snow break at the edge of the development.

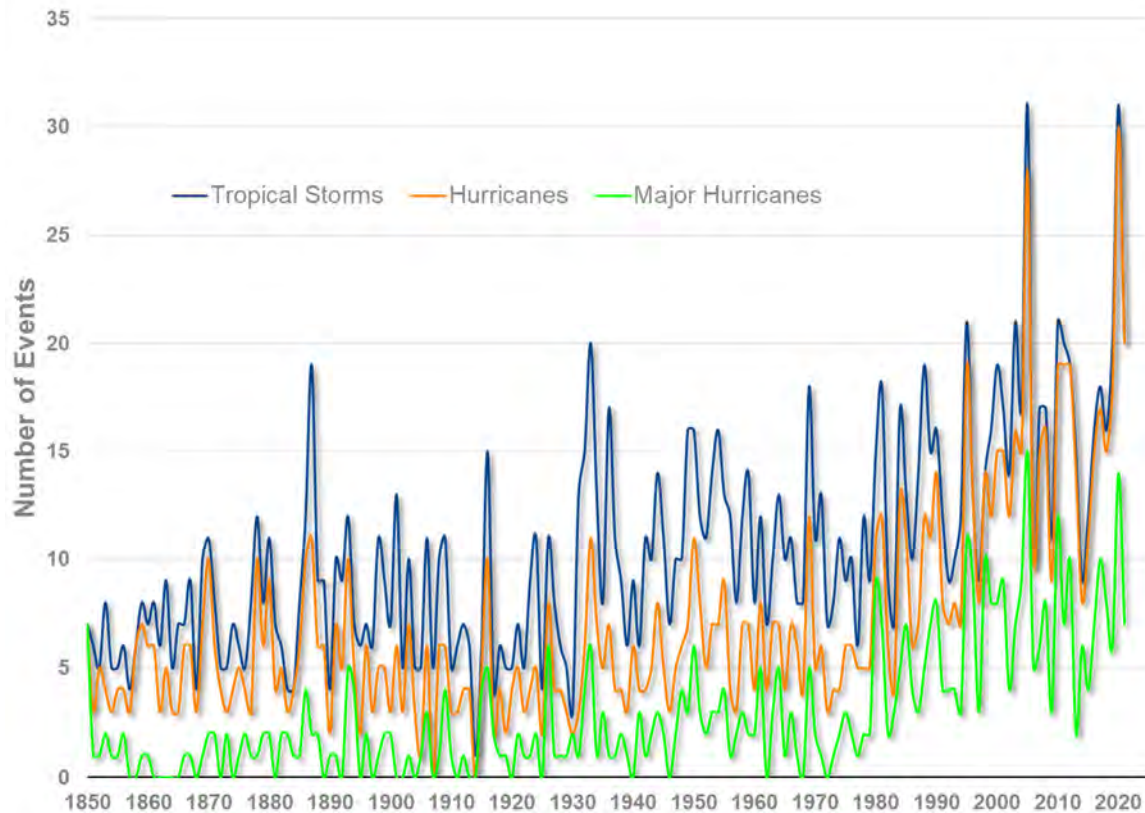

Figure 101. Number of named storms experienced annually within the Atlantic region between 1850 and 2020.

4.5.6 Wet and Dry Acid Deposition

An estimated 21 % to 75 % of Atlantic Canada's landmass receives an amount of acid deposition that exceeds critical loads where adverse environmental effects are evident [Meteorological Service of Canada, 2004]. Fossil fuel combustion in power generating plants, smelting operations, petroleum refining, and motor vehicles produce large quantities of sulfur and nitrogen oxides that are emitted to the atmosphere [Sawyer *et al.*, 1994; Craig *et al.*, 1996]. Those oxides (*i.e.*, acid gases) are often emitted through tall stacks that introduce the pollutants to areas of the atmosphere where there are stronger and more persistent winds [Lutgens and Tarbuck, 2001]. The use of tall stacks helps reduce local pollution, but through the process of long-range transport it can aggravate downwind regional pollution problems [Langmuir, 1997].

Once in the atmosphere, those acid gas emissions can be scavenged by water droplets and fall to the Earth's surface as acid precipitation (*i.e.*, having a pH < 5.0 and in the form of dew, drizzle, fog, sleet, snow, and rain) in the form of sulfuric and nitric acid [Murphy and Nance, 1998]. Dry deposition (*i.e.*, particulates, gases, and aerosols) can also occur and once on the ground surface those deposits can be entrained by water to form acids as well [Henry and Heinke, 1996].

Wet and dry deposition of acids can be problematic in New Brunswick. That is because fallout from the heavy industrialized areas of Michigan, Indiana, Ohio, western Pennsylvania, and southern Ontario and Quebec generally occurs in the region [JJC,

2020]. Those emissions can wreak havoc on the region's environment. Because the deposition is sourced from far away, there is little that can be done locally to curb the potential impacts. Instead, design and mitigation measures must be developed to account for the potential impacts.

In October 1998, federal, provincial, and territorial Energy and Environment Ministers signed *The Canada-Wide Acid Rain Strategy for Post 2000* [CCME, 2013]. Part of that strategy called for reducing domestic acidifying emissions in New Brunswick. In that vein, emissions caps and stack emissions limits were introduced for existing facilities. Air emissions from new major sources became regulated through the issuance of ATOs under the New Brunswick *Clean Air Act* [S.N.B. 1997, c C-5.2]. A facility's ATO stipulates emissions limits and conditions under which reporting is required. Similar programs to New Brunswick's have been applied to emissions in other Atlantic provinces. Overall, the implementation of those programs has yielded a reduction in emissions (Figure 102) and the subsequent decline in the production of sulfuric and nitric acid formation from those pollutants. Although, the reductions have levelled out, progress can still be made.

It is possible that wet and dry acid deposition will have an impact on the proposed Project. Although it is likely that some structures will be affected, the damage is expected to be minimal or occur in a manner that is not mechanically or operationally destructive to the structure during its expected lifetime. Climate change could have a negative impact on the amount of acid precipitation contacting the Project. For example, predicted increases in precipitation could yield more wet acid deposition leading to increased destruction to the facilities.

The following is a list of some concerns related to wet and dry acid deposition that could pose an impact to this Project:

- etching and dissolving of concrete;
- enhanced steel corrosion;
- etching on glass windows; and
- increased insurance costs.

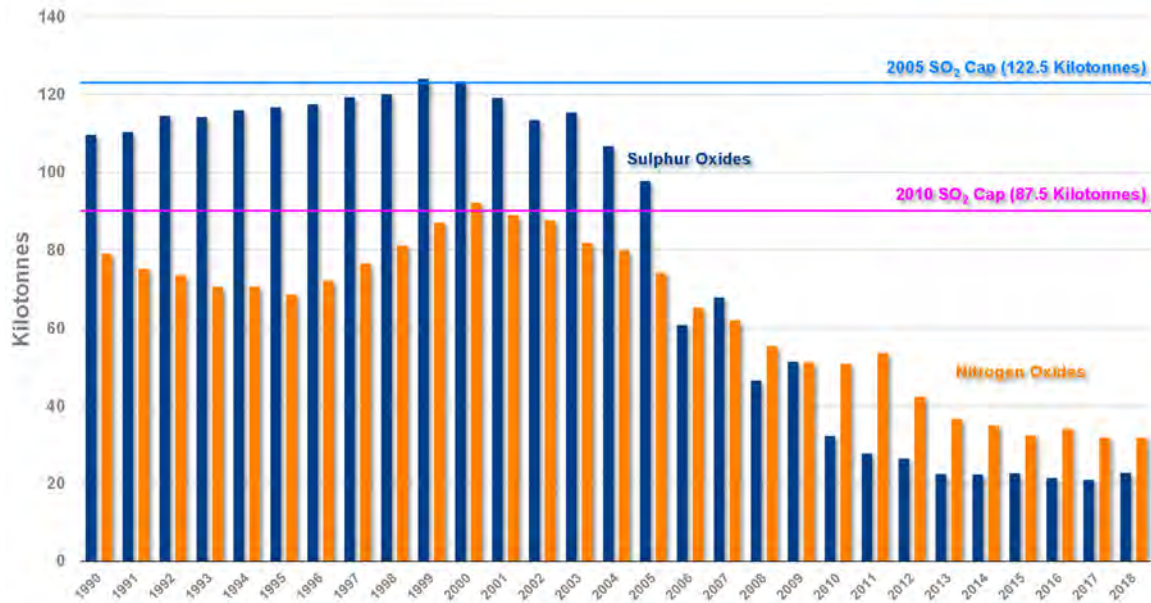

Figure 102. Historical sulphur oxide and nitrous oxide emissions for New Brunswick as reported by the *ECCC* [2021d].

Below is the mitigation offered for wet and dry acid deposition.

- Design professionals should use sound engineering practices to provide mitigation and ensure that those concerns associated with wet and dry acid deposition are addressed.
- Materials specified for the Project should be in compliance with the applicable standards and codes (*n.b.*, the National Building Code of Canada provides for factors of safety to account for possible extreme weather that could arise from climate change).

4.5.7 Seismic Activity

New Brunswick lies within the northeastern corner of the Northern Appalachians seismic zone (NAP; Figure 103). According to the *Geological Survey of Canada* [2021], approximately 330 earthquakes greater than magnitude (M) 2.5 occurred within the NAP between 1764 and 2001 (*n.b.*, pre-1960s, the M was estimated based on newspaper articles and historical documents while Earthquakes Canada's seismograph network has been used to detect earthquakes post-1960 whose M > 2.5). On average, approximately three events greater than an M 5 occur each decade (*i.e.*, those earthquakes that are potentially damaging to structures).

Burke [1984] noted that the epicentres of recent earthquakes in the NAP coincide with larger historical earthquakes; those regions that were lively in the past remain active today. The New Brunswick earthquake records show a clustering of earthquake epicentres in three sub-zones: Passamaquoddy Bay (PB); Central Highlands (CH); and Moncton (MO) [*Burke*, 2004]. *Halchuk et al.* [2004] calculated the maximum likelihood probability estimates for the three subzones with respect to the entire NAN. Activity rates were higher by a factor of two for the CH, higher by a factor of two to three for PB, and lower by a factor of 0.5 for MO (*n.b.*, MO was identified by *Burke* [1984] as a sub-zone because an

earthquake with an $M > 5$ was recorded there). The intraplate earthquakes in those three sub-zones are thought to be a result of either old fault line reactivation, the concentration of stress at pluton boundaries, or glaciostatic movements.

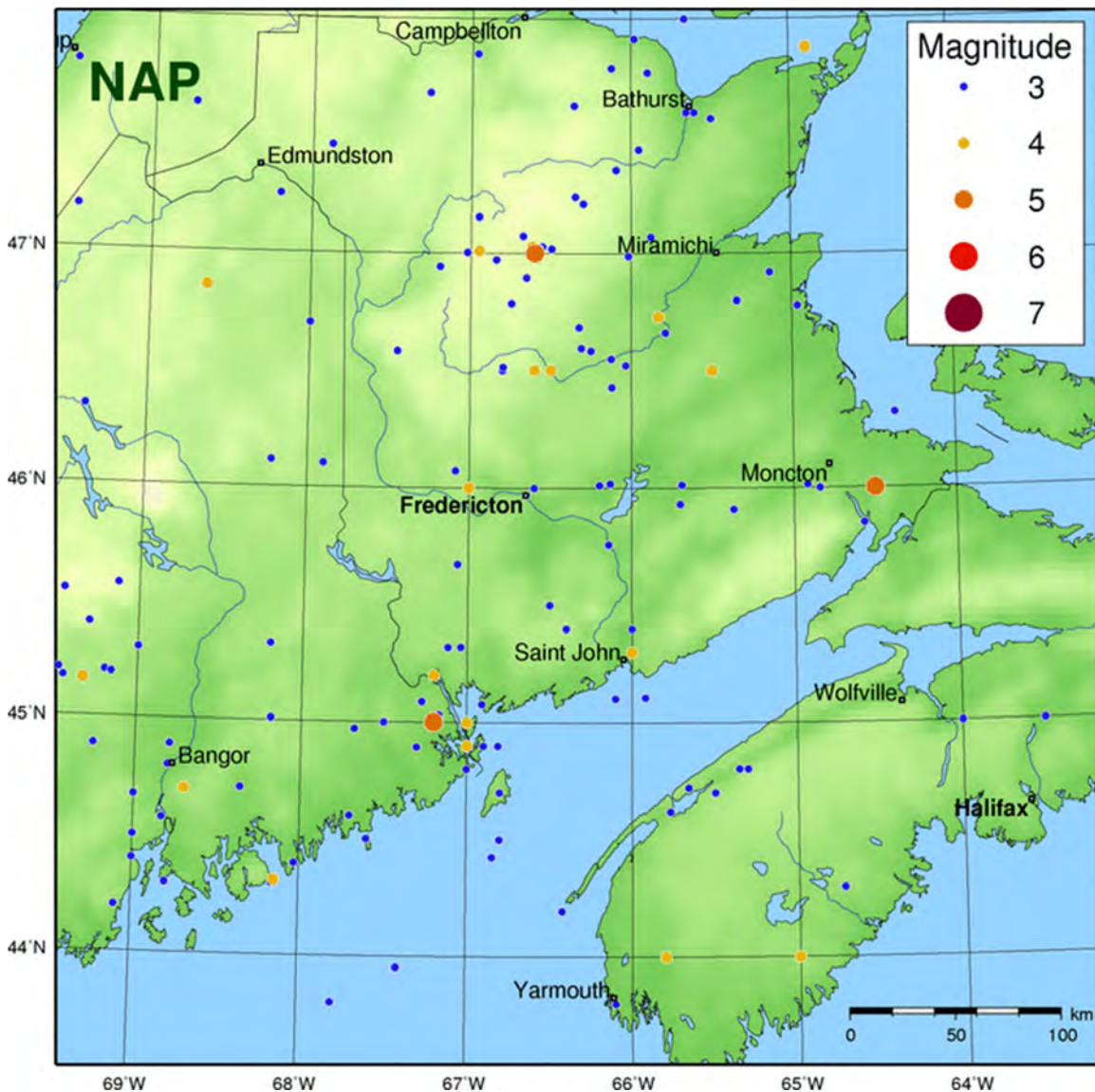

Figure 103. Map showing the Northern Appalachian Seismic Zone (NAP) from *Geological Survey of Canada* [2021].

Significant Canadian earthquakes for the period 1600 to 2017 were catalogued by *Lamontagne et al.* [2018]. Of the 172 significant events, seven occurred within the NAP (Table 72). The largest historically reported event for the NAP struck the PB sub-zone on 21 March 1904. Foreshocks and aftershocks accompanied that earthquake, which reportedly caused minor building damage (e.g., throwing of chimneys) and was felt throughout the Maritimes [*Burke*, 2013]. The 9 January 1982 Miramichi earthquake, which produced two sizeable aftershocks (i.e., an M 5.1 and an M 5.4, respectively, 3.5 hours and 2.5 days after the mainshock), was the most recent significant event and was also the most comprehensively studied in the NAP [*Broster and Burke*, 2011].

Table 72. Significant earthquakes recorded in New Brunswick between 1600 and 2017 as reported by *Lamontagne et al.* [2018].

Date	Sub-Zone*	Latitude (° N)	Longitude (° W)	Magnitude	Magnitude Type†
22 May 1817	PB	45.0	67.2	4.8	m _N
8 February 1855	MO	46.0	64.5	5.2	m _N
22 October 1869	CH	46.5	66.5	5.7	M _f (IV)
21 March 1904	PB	45.0	67.2	5.9	M _f (IV)
22 July 1922	CH	46.5	66.6	4.9	M _{FA}
30 September 1937	CH	47.4	66.3	4.8	M _{FA}
9 January 1982	CH	47.0	66.6	5.8	m _N

NOTES:

*PB = Passamaquoddy Bay, MO = Moncton, and CH = Caledonia Highlands

†m_N = Nuttli or body wave magnitude, M_{FA} = felt area magnitude, and M_f (IV) = magnitude based on the Modified Mercalli Intensity IV area

Seismic threat studies for the NAP place most of New Brunswick in the moderate hazard range [Burke, 1984 and Broster and Burke, 2011]. When significant earthquakes strike, they can cause minor damage to buildings and infrastructure, and have some effects on natural features (e.g., floods from embankment failure, alteration to flow of rivers and springs, mass movements, tsunami along coasts, seiches in lakes, ground disturbance, etc.).

The Greater Saint John region is not considered to be within a defined active seismic zone. Statistics indicate that all of the recent earthquakes in the region have resulted in little significant damage (i.e., no considerable damage to structures). There is no evidence in the region to support any surface displacement in recent geologic time. It is likely that recent earthquakes in the region were a result of deep geological activity rather than shallow surface fault systems. Potential for disturbance and seismic activity within the region is considered low.

Standards dictate that all structures be designed and built to withstand earthquakes in the area (i.e., based on the probability of specific magnitude earthquakes within a specific return period). Those criteria ensure the integrity of the structure based on the level of earthquake risk in the area. If a minor earthquake were to occur in the area, construction and / or operation of the Project could be moderately affected. It is unlikely that a minor earthquake would cause extensive damage to Project structures. In the event of an extreme earthquake, the Project could receive damage such that it would not be economically feasible to repair; however, this is highly unlikely. An earthquake in between minor and extreme could cause moderate damage to Project structures, but it is likely that they could be repaired.

The Geological Survey of Canada regularly updates seismic hazard maps for Canada. The most recent edition of those maps was produced for the 2015 National Building Code Canada (NBCC; Figure 104). To determine the 2015 NBCC seismic hazard values at The Reversing Falls Mill site, Natural Resources Canada's seismic hazard calculator was used (http://www.seismescanada.nrcan.gc.ca/hazard-alea/interpolat/index_2015-en.php). The ground motion probabilities are summarized in Table 6.

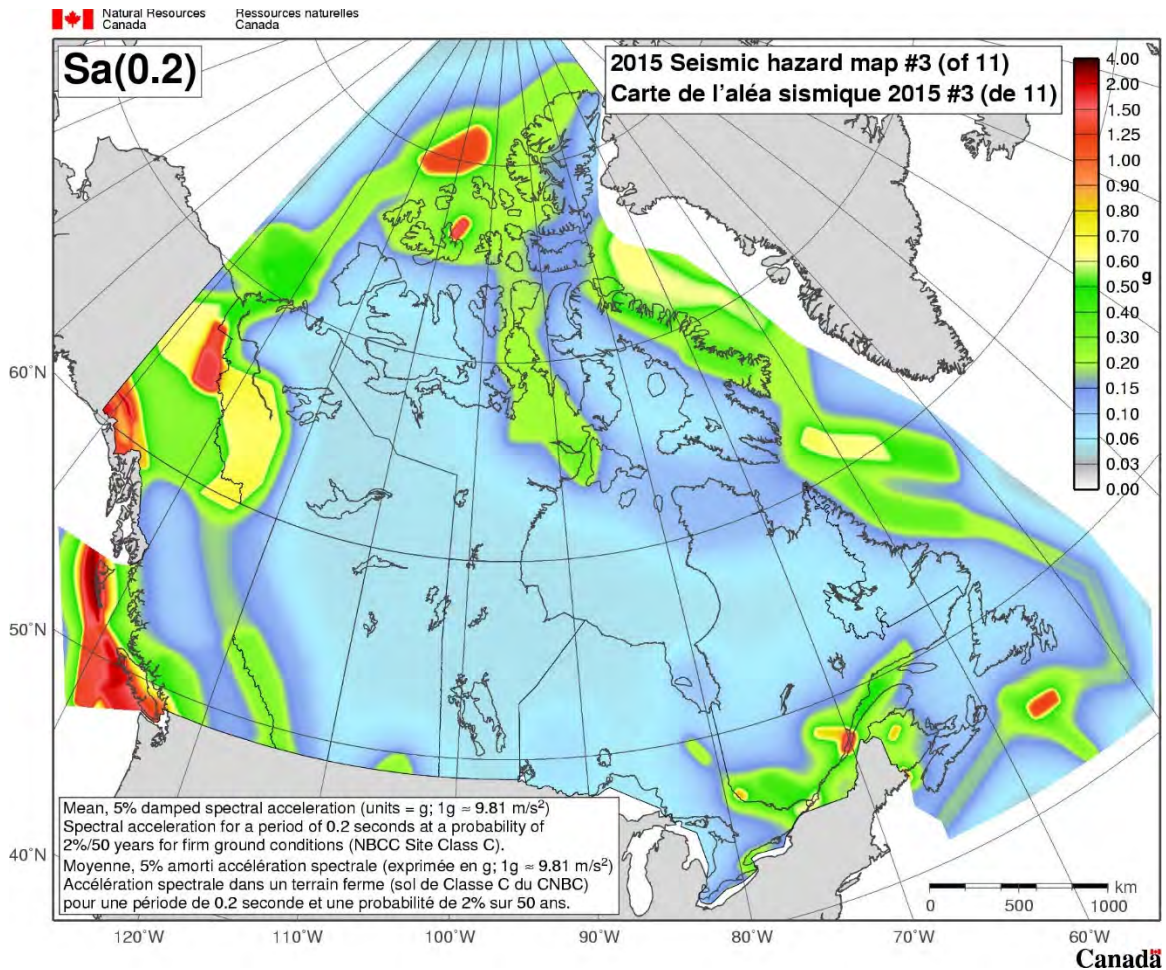

Figure 104. Spectral acceleration for a period of 0.2 s at a probability of 2 % · 50 yr⁻¹ for firm ground conditions (*i.e.*, NBCC soil class C) from *Natural Resources Canada* [2021].

Below is the mitigation offered for seismic activity.

All structures should be designed and built to withstand earthquakes in the greater Saint John region based on the probability of specific magnitude earthquakes within a specific return period (*n.b.*, the National Building Code of Canada provides for sufficient factors of safety to account for seismic activity in Canada).

Table 73. 2015 National Building Code interpolated ground motions calculated for the Reversing Falls Mill site in Saint John, New Brunswick using Natural Resources Canada's seismic hazard calculator.

Probability of exceedance per annum	0.010	0.0021	0.001	0.000404
Probability of exceedance in 50 years	40 %	10 %	5 %	2 %
Sa(0.2 s)	0.031 g	0.088 g	0.134 g	0.209 g
Sa(0.5 s)	0.021 g	0.055 g	0.082 g	0.125 g
Sa(1.0 s)	0.012 g	0.032 g	0.046 g	0.070 g
Sa(2.0 s)	0.005 g	0.016 g	0.023 g	0.035 g
Sa(5.0 s)	0.001 g	0.004 g	0.006 g	0.009 g
Sa(10.0 s)	0.001 g	0.002 g	0.002 g	0.004
Peak Ground Acceleration	0.017 g	0.052 g	0.082 g	0.131 g
Peak Ground Velocity	0.014 g	0.042 g	0.065 g	0.103 g

NOTES:

Spectral and peak hazard values are determined for firm ground (*NBCC* 2015 soil class C – with an average shear wave velocity of $450 \text{ m} \cdot \text{s}^{-1}$). The values were interpolated from a 10 km spacing grid of points. More than 95 % of the interpolated values yielded by the seismic hazard calculator are within 2 % of the calculated values.

4.5.8 Sea Level Rise

Sea-level rise can produce significant impacts on coastal zones, particularly for low-lying parts of Atlantic Canada. Those include storm impacts on the coast (*i.e.*, waves, surges, and flooding), sediment movement and erosion hazards, impacts on ecological systems (*e.g.*, coastal wetlands, fisheries, *etc.*), and damage to private and / or commercial property and public infrastructure [*Henton et al.*, 2006]. Throughout the course of this century, relative sea level is expected to rise in the Bay of Fundy because of global sea level rise and regional post-glacial rebound.

The IPCC Special Report on Emission Scenarios (SRES) A1B scenario estimates that global sea level is rising at about $4 \text{ mm} \cdot \text{yr}^{-1}$ and that by 2090-2099 relative global sea levels will rise 0.21 m to 0.48 m above 1980-1990 levels [*Bindoff et al.*, 2007]. Similar to historical observations, future sea level change will not be geographically uniform. Regional sea level change may vary within about $\pm 0.15 \text{ m}$ of the mean global projection. Thermal expansion of the oceans is projected to produce more than half of the average sea level rise, but land ice will lose mass increasingly rapidly as the century progresses. An important uncertainty relates to whether discharge of ice from the ice sheets will continue to increase as a consequence of accelerated ice flow, which has been observed in recent years [*Bindoff et al.*, 2007].

While most of Canada's landmass is currently experiencing uplift associated with post-glacial rebound, Atlantic Canada is experiencing subsidence. This is primarily due to unloading of the continental landmass (*i.e.*, collapse of the peripheral bulge, Figure 105) following the deglaciation of the Laurentide Ice Sheet coupled with the effects of rising post-glacial sea level loading on the continental shelf. Figure 105 shows the annual rates of post-glacial uplift and subsidence across Canada. The subsidence rates in Atlantic Canada are not particularly large, typically on the order of $-1 \text{ mm} \cdot \text{yr}^{-1}$ to $-2 \text{ mm} \cdot \text{yr}^{-1}$; however, the rates are in the opposite direction of sea level rise. Consequently, relative

sea-level rise, with respect to land, is regionally more rapid in Atlantic Canada than many other areas [Henton et al., 2006].

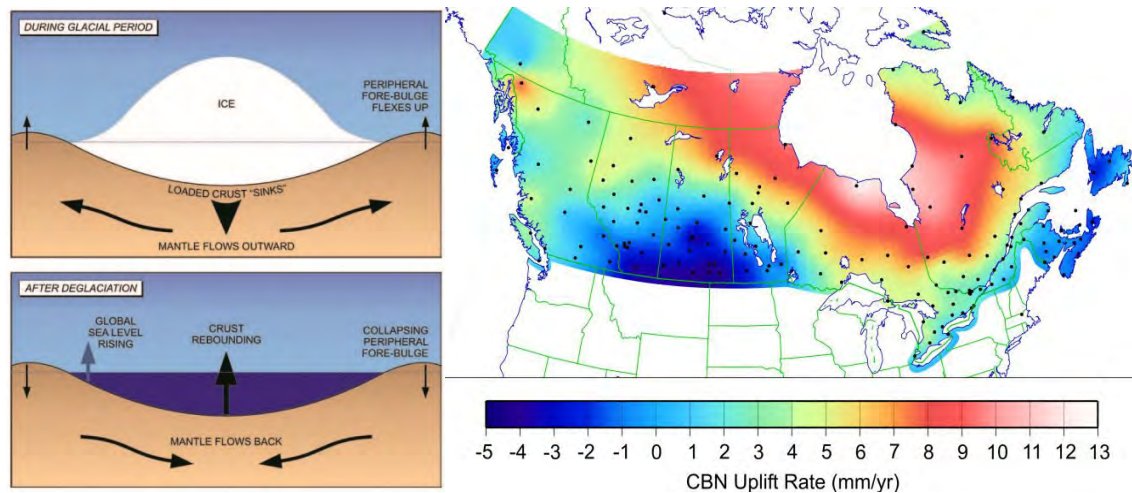

Figure 105. Schematics showing the generalized process of post-glacial rebound and map showing uplift and subsidence of land masses across Canada due to post-glacial rebound [Environment Canada, 2006]. Dots on the map represent Canadian Base Network (CBN) sites.

An Environment Canada [2006] study of sea level rise along New Brunswick's Northumberland Strait coastline anticipates that by 2100, global sea level rise and regional post-glacial subsidence will generate a relative sea level rise of between 19 cm and 91 cm. New Brunswick's Bay of Fundy coastline is experiencing similar post-glacial subsidence, but the effects of relative sea level rise along those two coasts may greatly differ. Northumberland Strait's low-lying shorelines are comprised of erodible material, which makes them much more susceptible to storm damage and erosion when compared to the rocky coastline of the Bay of Fundy. Recent climate change modeling by the Environment and Sustainable Development Research Centre (ESDRC) predicts that the relative sea level rise for Saint John is expected to increase by $85 \text{ cm} \pm 33 \text{ cm}$ by 2100 [ESDRC, 2010]. Those data for Saint John were further refined by Daigle [2020]. Total predicted changes are as follows:

- $0.17 \text{ m} \pm 0.07 \text{ m}$ between 2010 and 2030;
- $0.31 \text{ m} \pm 0.14 \text{ m}$ between 2010 and 2050;
- $0.86 \text{ m} \pm 0.38 \text{ m}$ between 2010 and 2100; and
- $1.51 \text{ m} + 0.38 \text{ m}$ between 2010 and 2100 with 0.65 m increase related to potential rise due to the melting of the Antarctic Ice Sheet.

Tides are of special significance within the Bay of Fundy. A funneling effect of the Bay as it narrows generates the world's highest tides. Tide predictions are available online through the DFO [2021a] and have been tracked in Saint John since 1896. Regular tides range between highs of 5.5 m to lows of 0.4 m. The highest tide recorded in Saint John since 1896 was 9.2 m [DFO, 2021b]. On 21 January 1943, the lowest mean water level of 3.725 m above chart datum was recorded for Saint John. Conversely, on 4 January 1997, the highest mean water level of 5.361 m above chart datum was recorded.

The Project site is at Reversing Falls where the Saint John River meets the Bay of Fundy. As noted previously (*i.e.*, refer to Section 3.1.5), the site is currently being built up with a protective berm at an elevation of 6.8 m to mitigate any impacts associated with sea level rise.

Climate Central, Inc.'s coastal risk screening tool (https://coastal.climatecentral.org/map/14/-66.0149/45.3211/?theme=sea_level_rise&map_type=coastal_dem_comparison&elevation_model=coastal_dem&fbclid=IwAR3zAZglzh7IRIJEGDAKB1o39mOFq6cA8NIKjXAWgTcnlvfCu0OKcgHvI&forecast_year=2070&pathway=rcp45&percentile=p50&return_level=return_level_1&slr_model=kopp_2014) was used to predict land projected to be below the 2030 (Figure 106), 2050 (Figure 107), and 2100 (Figure 108) during the annual flood level with sea level rise. The screening tool was used to identify the water level at the shoreline that local coastal floods exceed on average once annually. In the three figures, the blue shaded areas reflect areas that are lower than the selected local sea-level and / or coastal flood projection; however, there is a caveat. The “bathtub” approach used by Climate Central, Inc.'s model does not account for areas whose elevation falls below the selected water level where ridges or other features protect them from inundation at that level. It also does not account for coastal defenses, such as levees, like those being constructed at the site.

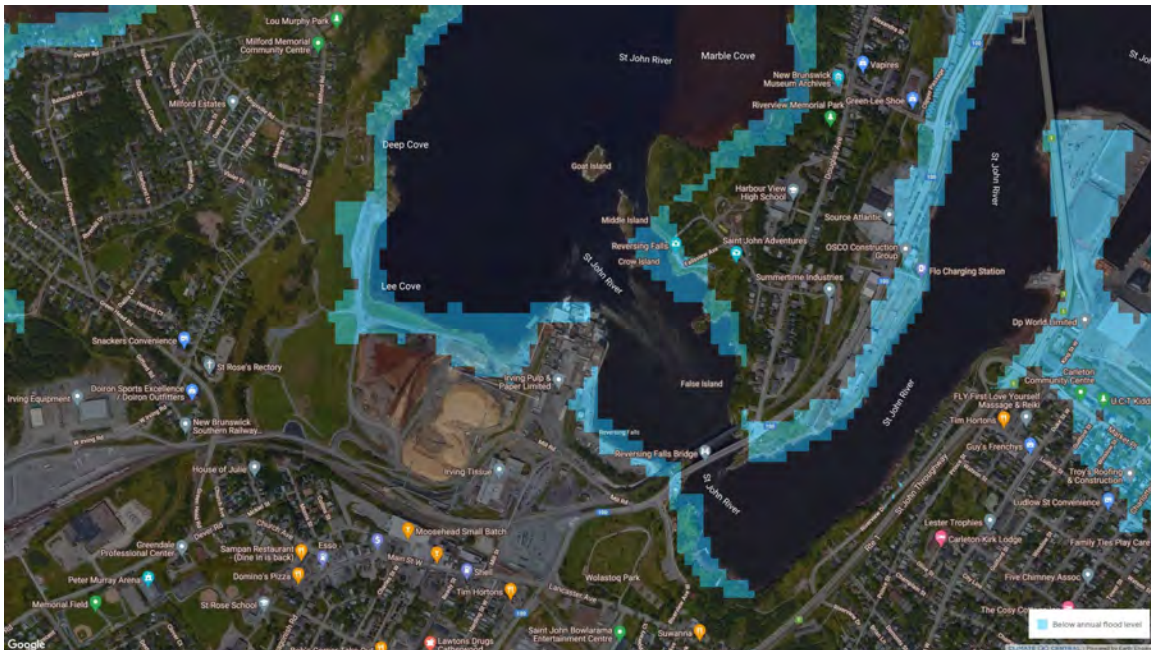

Figure 106. Land in vicinity of the Reversing Falls Mill in Saint John, New Brunswick that are projected to be below the 2030 annual flood level (*i.e.*, areas shaded blue).

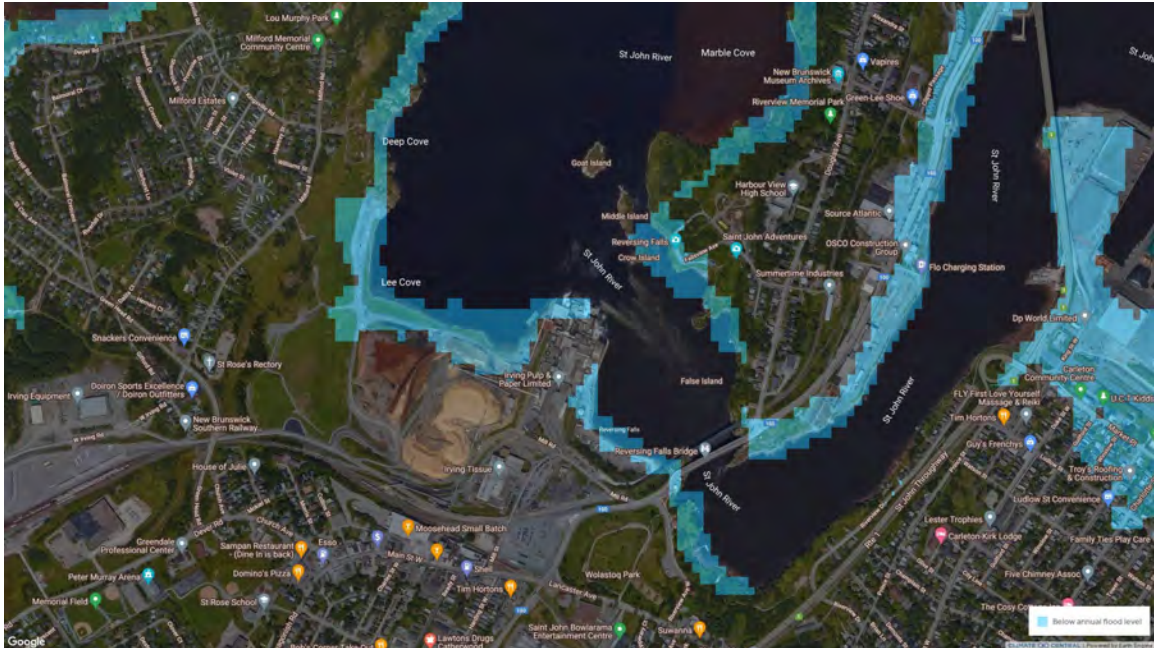

Figure 107. Land in vicinity of the Reversing Falls Mill in Saint John, New Brunswick that are projected to be below the 2050 annual flood level (*i.e.*, areas shaded red).

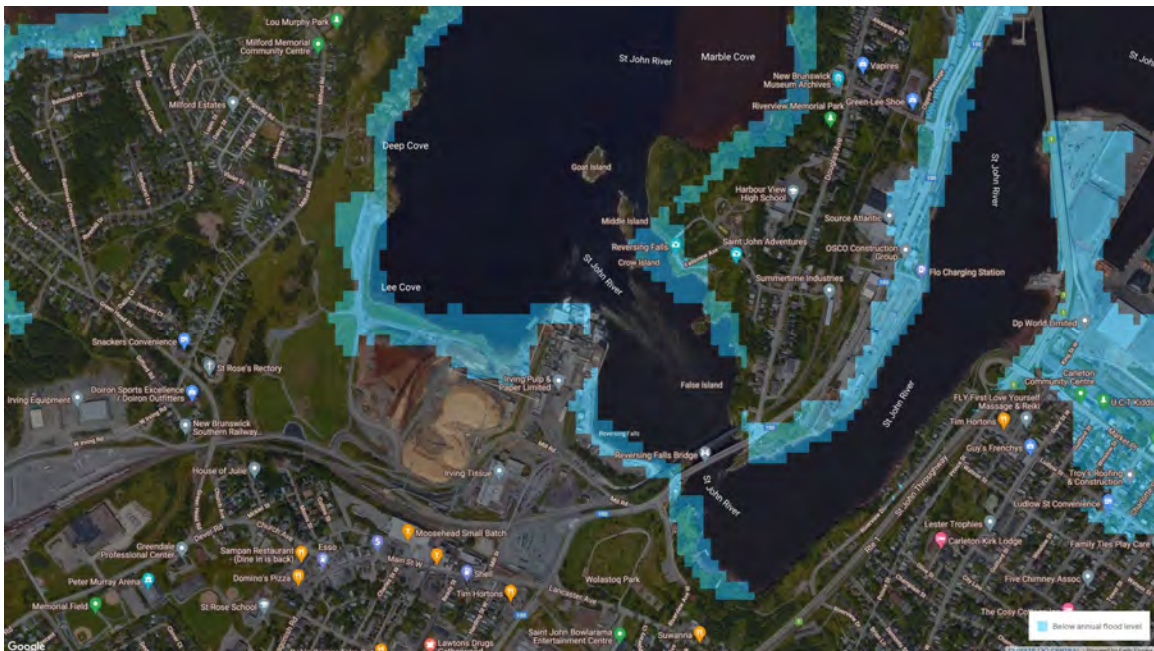

Figure 108. Land in vicinity of the Reversing Falls Mill in Saint John, New Brunswick that are projected to be below the 2100 annual flood level (*i.e.*, areas shaded red).

The following is a list of concerns associated with sea level rise that could result under a changing climate:

- unsafe work conditions;
- increased erosion;
- localized flooding;

- increased insurance costs; and
- increased stress and strain on structures (e.g., wind and wave action).

Because potential impacts are being planned for in the design, considerable impacts are not expected to occur; however, the mitigation measures provided below should be followed to reduce the likelihood of impacts being realized.

- Work should be halted if flooding causes unsafe working conditions.
- A surface water management plan, which includes an erosion and sedimentation control plan during construction, should be developed for the Project site.
- Structures that could be impacted by flooding, should be located well above ground-level.
- Structural engineers should account for increased stress and strain on structures resulting from wind and wave action under a changing climate.
- Protective flood berms at the site may have to be raised to protect against future sea level rise combined with annual flooding events.

4.5.9 Summary

The Proponent will ensure that the Project is being designed in accordance to strict standards and codes, such as the NBCC. That code tends to consistently overestimate and account for possible forces of the environment and incorporates several factors of safety to ensure that a project is designed to be safe and reliable throughout its lifetime. Through application of those criteria and implementation of the mitigation measures noted, the Project should withstand all impacts of the environment on it, even under a changing climate. Detailed mitigation strategies for potential impacts of the environment on the Project should be further discussed in the Project-specific EPP. In particular, the Project-specific EPP should ensure that there is:

- no long-term interruption in construction activities;
- no long-term interruption in scheduling of the Project;
- no long-term interruption in operation of the Project;
- no damage to infrastructure such that public health and safety are put at risk; and
- no change to infrastructure that would not be economically feasible to repair.

Compliance with design and building codes and standards are expected to account for the effects of climate change, weather extremes, seismicity, and sea level rise through built-in factors of safety to prevent undue damage to infrastructure from such events. Further, no substantial damages to project infrastructure are anticipated as a result of natural environmental conditions due to the design and type of activities proposed. Therefore, the effects of the environment are not expected to adversely affect the project in a manner that cannot be planned for or accommodated through design and other mitigation and adaptive management strategies. As a result, the effects of the environment on the project are expected to be not significant.

4.6 PROJECT-SPECIFIC ENVIRONMENTAL PROTECTION PLAN

A Project-specific environmental protection plan will be developed. The EPP will be an important component to the overall Project because it will dictate the importance of Best-Management Practices (BMPs) that shall be undertaken by all those associated with the Project to ensure environmental protection. The EPP will provide a practical means for conveying BMPs to IPP personnel for ensuring the implementation of the outlined standards and regulations throughout the entire Project. It will be a dynamic document to be used by Project personnel in the field and at the corporate level for ensuring commitments made in the EIA are implemented and monitored.

More specifically, the purpose of the EPP will be to:

- outline IPP's commitments to minimize potential Project environmental impacts, including commitments made during the regulatory review process of the EIA;
- comply with conditions and requirements of an "EIA Approval", if and when issued;
- comply with the conditions of any authorization(s), license(s), and / or permit(s) issued to complete the project;
- provide a reference document for IPP and all contractor personnel to use when planning and / or conducting specific Project activities; and
- provide a summary of environmental issues and protection measures to be implemented during the Project.

The EPP will be developed in accordance with applicable federal and provincial environmental protection legislation and regulations. IPP will continue to take a proactive approach toward creating a safe and secure work environment and maintain a system to manage environmental effects of the Project. They will identify health, safety, environmental, and security issues as part of the execution planning and manage the environmental effects of the Project and work in ways that are environmentally, economically, and socially justified and legally compliant. Specific health, environmental, safety, and security issues will be addressed in the execution plans and procedures for the Project.

5.0 FIRST NATIONS ENGAGEMENT AND PUBLIC CONSULTATION

The NBDELG has a prescriptive process for undertaking First Nations engagement and public consultation with respect to EIAs. This section describes the work that has been and will be done to engage First Nations and consult the public and stakeholders in the EIA process. It identifies the meetings that have been held and who was consulted.

For the Project EIA review to be inclusive and transparent, First Nations engagement and public consultation must be incorporated. IPP's First Nations engagement and public consultation plan is designed to inform and engage all the rights-holders and all stakeholder groups about the Project in order to encourage participation and gather feedback. The overall goal of the process is to ensure that those potentially affected by the Project are aware of it, are able to obtain additional information, and have the option to identify impacts to Rights, and express any issues and concerns they may have. The process involves gathering input, identifying potential issues, and ensuring understanding of the Project among all parties.

The information collected during the First Nations engagement and public consultation process is taken into account by the Minister during the EIA decision-making process. In support of that, the Proponent must prepare a report for the NBDELG. That report will document the public consultation process and outline the issues that were brought forward, those issues that were corrected, and those issues that were not resolved. In addition, that report will document the engagement with First Nations, and outline any impacts to Rights that were identified, how those identified impacts were avoided, minimized or mitigated, or if those impacts were not resolved. In addition to impacts to Rights, the report will also identify any other issues of concern to First Nations, issues that were addressed, and issues that were not resolved.

On-going First Nations engagement and public and stakeholder consultation will occur throughout the regulatory review process to collect feedback and enhance the Project's development.

5.1 PARTIES INCLUDED

5.1.1 First Nations

The Project site is located within the traditional Maliseet territory of the Wolastoqiyik. Section 35 of the *Constitution Act, 1982* [U.K., 1982, c 11] "recognizes and affirms" the "existing" Aboriginal and treaty rights in Canada and the duty to consult. Aboriginal rights derive from the long-standing use and occupancy of the land prior to the arrival of settlers. Those Aboriginal rights protect the activities, practice, or traditions that are integral to the distinct cultures of Aboriginal peoples. The treaty rights protect and enforce agreements between the Crown and Aboriginal peoples. Section 35 also provides protection of Aboriginal title, which protects the use of land for traditional purposes. In New Brunswick, First Nations are rights-holders and they require consultation by the Crown when the Duty to Consult is triggered.

It is best practice for proponents to engage with First Nations communities in New Brunswick. This engagement should be done both early and often. to build trust and to avoid costly delays to a proponent's project. Although the provincial government has the

During Duty to Consult with First Nations communities during the EIA review process, it is a recognized best practice for a proponent like IPP to engage early and often with First Nations. The goal of early engagement is to identify issues and impacts to Rights early and to address issues and impacts in the design stage of a project (*i.e.*, by avoiding, minimizing, or mitigating impacts). Appropriate and meaningful engagement promotes transparency, collaboration, and builds long-term relationships.

The Wolastoqey Nation in New Brunswick (WWNB) provides technical advice to Wolastoqey communities and offers support to ensure that the constitutional Duty to Consult is being met and that Aboriginal and Treaty rights are recognized and implemented. The First Nations communities WWNB represents are:

- Welamakotuk (Oromocto);
- Sitansisk (Saint Mary's);
- Pilick (Kingsclear);
- Wolastokuk / Woolastoogiw (Woodstock);
- Neqotkuk (Tobique); and
- Kapskuksisok (Madawaska).

The Mi'gmawe'l Tplu'taqnn Inc. (MTI) holds the mandate of consultation and accommodation and rights implementation for its Mi'kmaq member communities. The First Nations communities represented by MTI are:

- Amlamgog (Fort Folly);
- Esgenoôpetitj (Burnt Church);
- L'nui Menikuk (Indian Island);
- Metepenagiag (Red Bank);
- Natoaganeg (Eel Ground);
- Tjipōgtōtjg (Bouctouche);
- Ugpi'ganjig (Eel River Bar); and
- Oinpegitjoig L'Noeigati (Pabineau).

The Mi'kmaq First Nation Elsipogtog is a member community of MTI, but not represented by MTI for the purposes of consultation. Instead, that First Nation consults directly with the government. Similarly, the Peskotomuhkati First Nation consults directly with government.

Best practices for engagement with First Nations includes:

- learning about the First Nations communities affected and their Aboriginal culture;
- mutual respect;
- early engagement;
- being open and transparent;
- listening with an open mind; and
- adapting where possible to avoid impacts to Aboriginal rights.

Each of the Chiefs of the above communities are to be sent correspondence as part of the engagement process. Table 74 lists those individuals who will be sent formal notification of the Project registration document (*i.e.*, in the form of an information letter).

Table 74. Chiefs and Consultation Directors of New Brunswick's First Nations who will be sent information regarding the environmental treatment facility and water use reduction project proposed for the Reversing Falls Mill in Saint John, New Brunswick.

First Nation Group / Community	Chief	Consultation Coordinator(s)	Address
<u><i>Mi'qmaew'l Tplu'taqnn, Inc. (MTI) Members*</i></u>			
Amlamgog (Fort Folly)	Rebecca Knockwood		38 Bernard Trail, PO Box 1007, Dorchester, NB, E4K 3V5
Esgenoôpetitj (Burnt Church)	Alvery Paul		620 Bayview Drive, Burnt Church, NB, E9G 2A8
L'nui Menikuk (Indian Island)	Kenneth Barlow		61 Island Drive, Indian Island, NB, E4W 1S9
Metepenagiag (Red Bank)	William (Bill) Ward		PO Box 293, Metepenagiag Mi'kmaq Nation, NB, E9E 2P2
Natoaganeg (Eel Ground)	George Ginnish		47 Church Road, Eel Ground, NB, E1V 4E6
Tjipôgtôitj (Bouctouche)	Brenton LeBlanc		9 Reserve Road, Bouctouche Reserve, NB, E4S 4G2
Ugpi'ganjiq (Eel River Bar)	Sacha LaBillois		11 Main Street, Unit 201, Eel River Bar, NB, E8C 1A1
Oinpegitjoig L-Noeigati (Pabineau)	Joseph Terence Richardson		1290 Pabineau Falls Road, Pabineau First Nation, NB, E2A 7M3
<u><i>Independent Mi'qmaq[†]</i></u>			
Elsipogtog	Arren Sock		Kopit Lodge, 33 Riverside Drive, Elsipogtog, NB, E4W 2Y6
<u><i>Wolastoqey Nation of New Brunswick (WNNB) Members[‡]</i></u>			
Welamakotuk (Oromocto)	Shelley Sabattis	Fred Sabattis, Robert Paul	PO Box 417, Oromocto, NB, E2V 2J2
Sitansisk (Saint Mary's)	Allan Polchies Jr.	Tim Plant	150 Cliff Street, Fredericton, NB, E3A 0A1
Pillick (Kingsclear)	Gabriel Atwin	Richard Francis	77 French Village Road, Kingsclear First Nation, NB, E3E 1K3
Wotstak (Woodstock)	Tim Paul	Amanda McIntosh	3 Wulastook Court, Woodstock First Nation, NB, E8C 1A1
Neqotkuk (Tobique)	Ross Perley	Jamie Gorman	13094 Route 105, Tobique, NB, E7H 3Y4
Matawaskiye (Madawaska)	Patricia Bernard	Russ Letica, Shawn Francis	1771 Principale Rue, Madawaska First Nation, NB, E7C 1W9
<u><i>Peskotomuhkati Nation at Skutik[§]</i></u>			
Peskotomuhkati	Hugh M. Akagi		93 Milltown Boulevard, Suite 201, St. Stephen, NB, E3L 1G0

NOTES:

*When corresponding with MTI member Chiefs, carbon copy Dean Vicaire (Executive Director of MTI), Derek Simon (Legal Counsel at MTI), and Jennifer Coleman (Intergovernmental Affairs at MTI) at 40 Micmac Road, Eel Ground, NB, E1V 4B1

[†]When corresponding with Chief Arren Sock, carbon copy Kopit Lodge and Alex Levi (Communications Engagement Coordinator)

[‡]When corresponding with WNNB member Chiefs, carbon copy Shyla O'Donnell (Consultation Director at WNNB), Gillian Paul (Legal and Governance Advisor), and Gordon Grey (EIA Coordinator)

[§]When corresponding with Chief Hugh Akagi, carbon copy, Cynthia Howland (Executive Assistant to Chief Akagi) John Ames (Director of Operations)

5.1.2 Local Residents and Stakeholders

Fundy Engineering and IPP will reach out to local residents and stakeholders. Stakeholders including Non-Government Organizations (NGOs) (*i.e.*, The Chamber, Envision SJ, Uptown Saint John, and the Saint John Construction Association), and community groups (*i.e.*, ACAP Saint John, Conservation Council of New Brunswick, and Saint John Citizens' Coalition for Clean Air). Stakeholders are generally direct conduits to the community. Relayed Project information will include:

- who is involved;
- what is the purpose of the proposed Project;
- where the proposed Project will occur;
- when the proposed Project will occur;
- why the proposed Project is being considered; and
- how the proposed Project will be undertaken.

5.1.3 Regulatory Agencies

The NBDELG, through the EIA regulation [87-83] of the *Clean Environment Act* [R.S.N.B. 1973, c. C-6] and approval of the Mill's existing ATOs (*i.e.*, Appendix II), has regulatory jurisdiction over this Project. The provincial government has a constitutional Duty to Consult [NBAAS, 2011] and where required, accommodate Aboriginal Peoples, whenever a decision or activity could adversely impact Aboriginal or Treaty rights. The provincial government must also ensure First Nations are given a meaningful opportunity to provide input on the Project.

5.2 PRE-REGISTRATION ENGAGEMENT AND CONSULTATION

5.2.1 New Brunswick Department of Aboriginal Affairs

The provincial government is responsible for the overall consultation process and must ensure that consultation and accommodation are appropriate for the circumstances prior to determining whether a project can proceed. The government, through the New Brunswick Department of Aboriginal Affairs, is responsible for overseeing and ensuring the adequacy of the Proponent's engagement efforts as well as assessing any proposed mitigation strategies and accommodation measures developed in response to concerns raised by First Nations.

5.2.2 First Nations

Proponents are encouraged to engage with First Nations early in the development of a project. The engagement steps that should occur throughout the life of a project, include:

- early and meaningful engagement (*i.e.*, pre-EIA application);
- standard engagement (*i.e.*, EIA application submitted and under review);
- engagement and accommodation (*i.e.*, EIA application submitted and under review);
- follow-up engagement (*i.e.*, approved EIA applications).

Conducting engagement in this manner ensures that there is an opportunity to identify impacts to Rights and provide IPP the opportunity to develop plans that avoid, minimize, or mitigate impacts to Rights at the earliest possible opportunity in the engineering and design process. Identifying and addressing impacts early should ensure improved impact resolution, reduced costs, and avoid delays.

In recent years and while working on other projects, IPP has invested in efforts to build relationships with First Nations communities in New Brunswick. This has included cultural awareness training (*i.e.*, via participation in the “Blanket Exercise” by IPP senior leadership and engineering staff), presentations regarding Mill operations, site tours, and a commitment to sharing regulatory documents with interested communities prior to submission to the Regulator(s). With respect to this Project, IPP began engaging with First Nations in October 2020. This has included two presentations providing a recent history of environmental treatment at IPP, the current situation, and sharing draft forward-looking plans for environmental treatment at IPP.

Appendix XIII provides a summary of First Nations engagement that has been completed to date. During First Nations engagement, items raised included the potential to discover archaeological resources during site development and temperature changes to the Saint John River after the Project is in operation. To protect archaeological resources, IPP will be engaging the Wolastoqey Nation in New Brunswick to train contractors and employees on their *Accidental Discovery of Archaeological Resources Protocol*. This Project will not significantly change the temperature of Mill Cove.

5.2.3 New Brunswick Department of the Environment and Local Government

Prior to registering a project, the NBDELG recommends discussing it with Project Assessment Branch representatives in order to:

- obtain advice and guidance on the submission of the EIA registration document and the review process;
- obtain information with respect to the possible timing and duration of the review for the EIA document; and
- provide the NBDELG personnel with advance notice of the anticipated timing for preparation and submission of the EIA document.

5.2.3.1 21 September 2021

On 21 September 2021, a pre-registration consultation meeting was held between representatives of the NBDELG and IPP (Table 75). Following social-distancing guidelines and COVID-19 protocols, the meeting was held by videoconference. An overview of the work being completed at the Mill during routine upgrades was discussed as was the proposed environmental treatment facility and water use reduction project.

Table 75. Attendees of the pre-registration consultation videoconference held on 21 September 2021 regarding the proposed environmental treatment facility and water use reduction project at the Reversing Falls Mill in Saint John, New Brunswick.

Name	Affiliation
Sheryl Johnstone	NBDELG, Permitting Engineer
Cathy Dubee	NBDELG, Region 4 Inspector
Renee Morais	JD Irving, Director of Environment
Cory Gallant	IPP, Mill Manager
Adam Brown	IPP, Assistant Mill Manager
Kirby McCracken	IPP, Health and Safety Specialist
Jason Smith	IPP, Technical Manager
Helen Tanfara	IPP, Environmental Coordinator
Kathleen McConnell	IPP, Process Engineering
Kyle Graves	IPP, Project Manager
Davyani Vasta	IPP, Intern

5.2.3.2 6 October 2021

On 6 October 2021, a pre-registration consultation meeting was held between representatives of the NBDELG and IPP (Table 76). Following social-distancing guidelines and COVID-19 protocols, the meeting was held by videoconference. An overview of the environmental treatment facility and the water use reduction Project was presented.

Table 76. Attendees of the pre-registration consultation videoconference held on 6 October 2021 regarding the proposed environmental treatment facility and water use reduction project at the Reversing Falls Mill in Saint John, New Brunswick.

Name	Affiliation
Crystale Harty	NBDELG, Director Environmental Impact Assessment Branch
Sheryl Johnstone	NBDELG, Permitting Engineer
Renee Morais	JD Irving, Director of Environment
Cory Gallant	IPP, Mill Manager
Jason Smith	IPP, Technical Manager
Helen Tanfara	IPP, Environmental Coordinator
Kyle Graves	IPP, Project Manager
Matt Alexander	Fundy Engineering, Environmental Scientist

5.2.3.3 2 February 2022

On 2 February 2022, a pre-registration consultation meeting was held between representatives of the NBDELG's proposed TRC and IPP (Table 77). Following social-distancing guidelines and COVID-19 protocols, the meeting was held by videoconference. An overview of the environmental treatment facility and the water use reduction Project was presented.

Table 77. Attendees of the pre-registration consultation videoconference held on 2 February 2022 regarding the proposed environmental treatment facility and water use reduction project at the Reversing Falls Mill in Saint John, New Brunswick.

Name	Affiliation
Crystale Harty	NBDELG, Director Environmental Impact Assessment Branch
Patrick Mbaya	NBDELG, EIA Project Manager
Sheryl Johnstone	NBDELG, Permitting Engineer
Catherine Lambert	NBDELG, Surface Water Management Technician
Courtney Johnson	NBDELG, Surface Water Management Biologist
Courtney Stadler	NBDELG, Surface Water Management Biologist
Cathy Dubee	NBDELG, Region 4 Inspector
Barry Leger	NBDELG, Permitting South Engineer
Robert Capozzi	NBDELG, Director Adaptation Section
Mallory Gilliss	NBDELG, Permitting North Hydrogeologist
Scott King	NBDTI, Environmental Technologist
Rita Mroz	ECCC, Expert Support and Contaminated Sites
Stephen Zwicker	ECCC, Environmental Assessment Coordinator
Michelle Daigle	ECCC, Manager of Labour Relations
Maryam Fazeli	ECCC, Physical Science Officer
Brian Drover	ECCC, Expert Support and Contaminated Sites
Angeline Leblanc	DFO, Shellfish Technician
Renelle Doucette	DFO, Biologist
Luc Savoie	DFO, Aquatic Science Technician
Trevor Ford	IAAC, Environmental Assessment Officer
Stephen Gray	Conservation Council of New Brunswick
Mark Mosher	JD Irving, Vice President Pulp & Paper
Chris Clark	JD Irving, Director of Pulp & Paper
Renee Morais	JD Irving, Director of Environment
Andrew Willet	JD Irving, Director of Aboriginal Relations
Cory Gallant	IPP, Mill Manager
Adam Brown	IPP, Mill Assistant Manager
Jason Smith	IPP, Technical Manager
Helen Tanfara	IPP, Environmental Coordinator
Kyle Graves	IPP, Project Manager
Matt Alexander	Fundy Engineering, Environmental Scientist

NOTES:

IAAC = Impact Assessment Agency of Canada

5.3 REGISTRATION ENGAGEMENT AND CONSULTATION

It is the Proponent's responsibility to demonstrate that the potentially affected public and other stakeholders are given the opportunity to actively participate in the EIA review process. Fundy Engineering has developed an organized information dissemination program, whereby relevant, sufficient, and credible information is presented to First Nations and the public.

The First Nations engagement and public consultation plan for this Project was developed in accordance with the process described in *A Guide for Proponents Engaging with Aboriginal Peoples in New Brunswick* [NBDA, 2019] and Appendix C of *A Guide to Environmental Impact Assessment in New Brunswick* [NBDELG, 2018]. The step-wise process proposed for the public consultation plan for this EIA is described in detail below. Our process satisfies the component of the NBDELG EIA Determination Review Summary highlighted in the blue box of Figure 82.

The public will be informed of this Project and the EIA registration document will be made available for review. Questions, comments, and concerns regarding the document will be collected and addressed as part of this process (*i.e.*, there is a two way flow of information between the proponent and the public with opportunities for the public to express their views).

5.3.1 Step 1: Direct Communication with Elected Officials and Service Groups

Formal notification of the Project registration document (*i.e.*, in the form of an information letter) will be sent to elected officials, local service groups and community groups, environmental groups, and other key stakeholder groups. Direct communication will enable those individuals and groups (*i.e.*, Table 78) to become more familiar with the Project, ask questions, and / or raise any and all issues / concerns.

Table 78. Elected officials, service groups, environmental groups, and stakeholders who will be sent information regarding the environmental treatment facility and water use reduction project proposed for the Reversing Falls Mill in Saint John, New Brunswick.

Name	Association	Address
Honourable Gary Crossman	Minister of Environment and Local Government	Marysville Place, PO Box 6000, Fredericton, NB, E3B 5H1
Honourable Mike Holland	Minister of Natural Resources and Energy Development	Hugh John Flemming Forestry Centre, PO Box 6000, Fredericton, NB, E3B 5H1
Honourable Dorothy Shephard	Saint John Lancaster MLA	HSBC Place, PO Box 6000, Fredericton, NB, E3B 5H1
Wayne Long	Saint John-Rothesay MP	1 Market Square, Suite N306, Saint John, NB, E2L 4Z6
Donna Reardon	Saint John Mayor	15 Market Square, Saint John, NB, E2L 4L1
John MacKenzie	Saint John Deputy Mayor	15 Market Square, Saint John, NB, E2L 4L1
Brent Harris	Saint John Councillor	15 Market Square, Saint John, NB, E2L 4L1
Gary Sullivan	Saint John Councillor	15 Market Square, Saint John, NB, E2L 4L1
Joanna Killen	Saint John Councillor	15 Market Square, Saint John, NB, E2L 4L1
Greg Norton	Saint John Councillor	15 Market Square, Saint John, NB, E2L 4L1
Barry Ogden	Saint John Councillor	15 Market Square, Saint John, NB, E2L 4L1
David Hickey	Saint John Councillor	15 Market Square, Saint John, NB, E2L 4L1
Gerry Lowe	Saint John Councillor	15 Market Square, Saint John, NB, E2L 4L1
Paula Radwan	Saint John Councillor	15 Market Square, Saint John, NB, E2L 4L1
Greg Stewart	Saint John Councillor	15 Market Square, Saint John, NB, E2L 4L1

Name	Association	Address
Roxanne Mackinnon	Executive Director ACAP Saint John	139 Prince Edward Street, Suite 323, Saint John, NB, E2L 3S3
Gordon Dalzell	Saint John Citizens' Coalition for Clean Air	32 Dorothea Drive, Saint John, NB, E2J 3J1
Blaine Harris	Executive Director Saint John Lancaster Business Assoc.	23 Main Street West, Saint John, NB, E2M 3M9
David Duplisea	The Chamber Executive Director	78 Prince William Street, Saint John, NB, E2L 2B3
Nancy Tissington	Uptown Saint John Executive Director	17-180 Canterbury Street, Saint John, NB, E2L 2C3
Paulette Hicks	Envision Saint John Chief Executive Officer	1 Germain Steet, Saint John, NB, E2L 4V1
Marc MacLeod	Fundy Regional Service Commission Executive Director	PO Box 3032, Grand Bay-Westfield, NB, E5K 4V3
Ray Riddell	President Saint John Naturalists' Club	PO Box 2071, Saint John, NB E2L 3T5

5.3.2 Step 2: Direct Written Communication with Nearby Residents

A limited mail out comprising a project information sheet will be sent to local residents and businesses. Residents and businesses of the following streets will receive information regarding the Project (Figure 109):

- McKiel Street;
- Church Avenue between Dever Road and Busby Street;
- Busby Street;
- Morris Street;
- Collins Street;
- Prospect Street West;
- Green Head Road to intersection of Dwyer Road;
- Gifford Road;
- Milford Road;
- Hernani Court;
- Dalila Court;
- Violet Street;
- Williams Street;
- Hawtrey Street;
- Kingsville Road;
- Tulip Street;
- Violet Street;
- Lupin Street;
- Daisy Street;
- Magnolia Street;
- Orchid Street;
- Primrose Street;

- Austin Lane;
- Shamrock Street;
- Dwyer Road;
- River Hill Drive;
- Silvermount Crescent;
- Glenburn Terrace;
- Starburst Lane;
- Balmoral Crescent;
- Balmoral Court;
- Saint Clair Avenue;
- Francis Street; and
- Allison Street.



Figure 109. Residential properties in the vicinity of the proposed Project at the Reversing Falls Mill in Saint John, New Brunswick that will receive notification of the Project.

5.3.3 Step 3: Notifications on the NBDELG Website and at the Head Office

The NBDELG shall place notice of the EIA registration on its website (*i.e.*, http://www2.gnb.ca/content/gnb/en/departments/elg/environment/content/environmental_impactassessment/registrations.html) and shall have the EIA document available for public review at the Project Assessment Branch head office located on the second floor of 20 McGloin Street in Fredericton, New Brunswick. To satisfy this requirement, IPP will provide an electronic version of the registration document (*i.e.*, as a PDF document) and two hard copies to the NBDELG.

5.3.4 Step 4: Documentation Availability with Stakeholder and NBDELG Offices

Copies of the Project registration document, and any subsequent submissions made in response to issues raised by the Technical Review Committee (TRC), will be made available at the local NBDELG office. A copy of the EIA document along with any subsequent revision(s) will be placed at the Saint John NBDELG regional office at 8 Castle Street where it will be made available to the public.

5.3.5 Step 5: Public Notice Announcement

As required, a public notice will be placed in at least one local newspaper that has general circulation in Saint John County and / or at least one provincial daily newspaper (*i.e.*, *Telegraph Journal*). The standard notice for an EIA registration document, which will be used for publicly announcing the proposed Project is presented in Figure 110.

NOTICE

Registration of Undertaking Environmental Impact Assessment Regulation Clean Environment Act, Opportunity for Public Comment

On 17 March 2022, Irving Pulp & Paper, Limited submitted for registration the following activity with the Department of Environment and Local Government in accordance with Section 5(1) and Schedule "A" of the Environmental Impact Assessment Regulation: "Environmental Impact Assessment: Environmental Treatment Facility and Water Use Reduction Project".

The Irving Pulp & Paper Mill is located at Reversing Falls in Saint John, New Brunswick. Continuous investments have been made and continue to be made in the Mill to maintain it as New Brunswick's Forest Products Industry anchor. This Project will be a significant investment in the Mill's environmental performance. An on-site moving bed biofilm treatment process will be built to meet or exceed the existing pulp and paper environmental treatment regulations and accommodate any future changes. A new heat exchanger system will allow the new environmental treatment facility to be built and operated entirely onsite and it will also reduce the amount of water drawn from Spruce Lake by up to half. This Project will position IPP among the global leaders in process water use and end of pipe treatment performance.

A public open house will be held on a date yet to be determined at a location near the Reversing Falls Mill.

The Proponent's registration document can be examined at:

Fundy Engineering 27 Wellington Row Saint John, NB	Saint John Free Public Library Market Square Saint John, NB
--	---

and at:

NBDELG Regional Office 8 Castle Street Saint John, NB	NBDELG Head Office 20 McGloin Street, 2 nd floor Fredericton, NB
---	---

Any comments should be submitted directly to the Proponent at:

Irving Pulp & Paper
% Fundy Engineering
27 Wellington Row
Saint John, N.B., E2L 3H4
matt.alexander@fundyeng.com

Receipt of comments is requested on or before 20 April 2022. Additional information about the proposal and the public involvement process is available at:
http://www2.gnb.ca/content/gnb/en/departments/elg/environment/content/environmental_impactassessment/registrations.html

Notice placed by: Irving Pulp & Paper, Limited.

Figure 110. Example of the public notice announcement that will be placed by the Proponent in at least one local newspaper and / or at least one provincial daily newspaper.

5.3.6 Step 6: Local Area Availability of the Registered Document

Copies of the Project registration document, and any subsequent submissions made in response to issues raised by the TRC, will be made available in at least two locations local to the Project. Locations proposed for viewing the document locally include the Saint John Free Public Library (*i.e.*, Market Square) and Fundy Engineering's Saint John office (*i.e.*, 27 Wellington Row). A copy of the Project registration document and any subsequent information will be made available to any First Nation, member of the public, and / or any stakeholder, upon request.

5.3.7 Step 7: Open House and / or Public Meeting

There is no requirement, under a Determination Review, to host an open house and / or public meeting; however, as a good environmental steward and neighbour, IPP intends to host an open house. The open house will involve the use of visual aids, staffed with Project personnel who will be able to answer questions and document issues and concerns. Tentatively, the open house will be conducted near the Reversing Falls Mill at a date and location yet to be determined. Details of the open house, including a list of attendees, questions asked, *etc.* will be included in the First Nations engagement and public consultation report submitted to the NBDELG.

5.3.8 Step 8: Documentation of Public Consultation Activities

The NBDELG Minister (*i.e.*, the Honourable Gary Crossman) will only provide an EIA determination once sufficient information has been received. This includes documentation of First Nations engagement and public and stakeholder consultations. Within 60 days of registering the proposed Project, a report documenting the above engagement and consultation process will be submitted to the NBDELG. In addition, this report will be made available for public review. The report will:

- detail First Nations engagement including a detailed communications log;
- describe the public consultation activities including copies of newspaper notices, and letters distributed;
- identify the key public and private stakeholders that were directly contacted during the public consultation process;
- include copies of any and all correspondence received from and sent to stakeholders and the general public;
- describe any issues or concerns received during the public consultation program, which includes the names and affiliations of the person(s) providing the comments;
- indicate how those issues and concerns were, or will be, considered and / or addressed; and
- describe any proposed future public consultation with respect to the Project.

IPP will adhere to the report requirements listed above. Given the Registration date of 17 March 2022 and the deadline of 20 April 2022 for public comments, the report documenting the First Nations engagement and public and stakeholder consultation process will be released prior to 20 May 2022.

6.0 PROJECT APPROVALS

For the proposed Project, legislation specifically applicable to the discharge of effluent from pulp and paper processes is as follows:

- federal *Canadian Environmental Protection Act, 1999* [**S.C., 1999, c. 33**]:
 - Pulp and Paper Mill Defoamer and Wood Chip Regulations [**SOR / 92-268**];
 - Pulp and Paper Mill Effluent Chlorinated Dioxins and Furans Regulations [**SOR / 92-267**];
- federal *Fisheries Act* [**R.S.C., 1985, c. F-14**]:
 - Pulp and Paper Effluent Regulations [**SOR / 92-269**]; and
- New Brunswick *Clean Environment Act* [**R.S.N.B. 1973, c. C-6**]:
 - Water Quality Regulation [**82-126**].

The legislation is designed to manage threats to fish, fish habitat, and human health by governing the deposit of deleterious substances from pulp and paper mills into waters frequented by fishes and waters used by humans. The Mill is already subject to these regulations, which will not change as a result of this Project.

Pulp and paper mills in Canada are required to implement several environmental best-management practices in their operations, such as:

- installing, maintaining, and calibrating mill effluent monitoring equipment and keeping records of that equipment;
- monitoring mill effluent;
- submitting monthly reports of mill pulp and paper production and effluent monitoring results;
- notifying an inspector of a test result that indicates a failure or non-compliance;
- preparing and updating annually a remedial plan describing the measures to be taken at the mill to eliminate all unauthorized deposits of deleterious substances in the case where mill effluent fails an acute lethality test;
- preparing an emergency response plan and making it readily available onsite to persons who are involved in implementing the plan;
- providing information related to the reference production rate;
- submitting information on outfall structures and only discharging mill effluent through those outfall structures;
- complying with requirements for environmental effects monitoring studies;
- keeping records available for inspection;
- requesting an authorization to combine effluents;
- providing written reports and additional sampling for the deposit of a deleterious substance in water frequented by fish that is not authorized under the *Fisheries Act* [**R.S.C., 1985, c. F-14**], which results or may result in detriment to fish, fish habitat, or the use of fish by humans.

Notwithstanding the above noted legislation, our understanding of the proposed Project requires several approvals. The sections below outline the federal, provincial, and

municipal approvals that are applicable to the Project to be built and operated. Figure 111 summarizes the permitting roadmap for this Project.

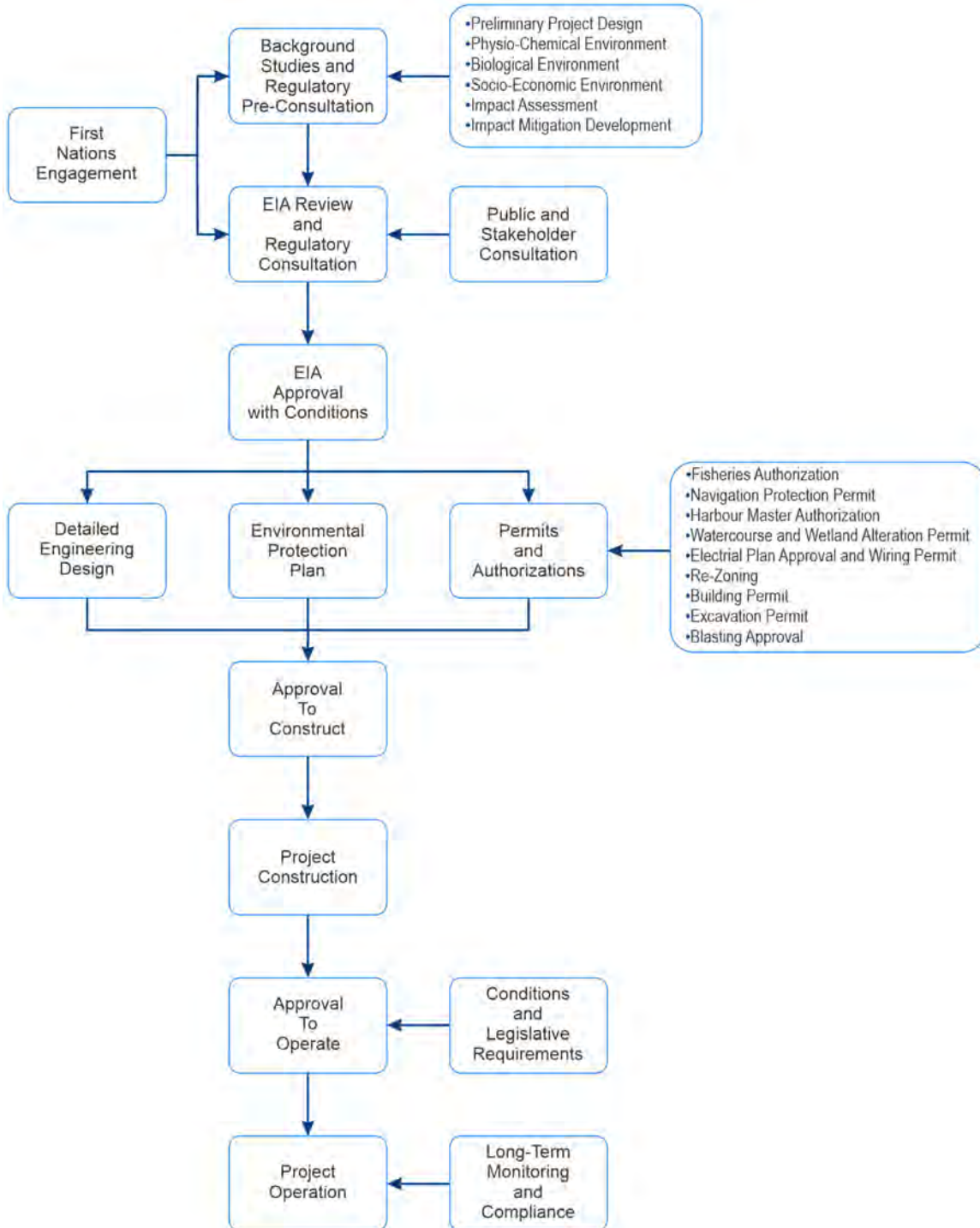

Figure 111. Permitting roadmap for the environmental treatment facility and water use reduction project proposed for the Reversing Falls Mill in Saint John, New Brunswick.

6.1 FEDERAL APPROVALS

6.1.1 Fisheries Act Authorization

On 6 February 2018, changes were proposed to restore lost protections and incorporate modern safeguards into the *Fisheries Act* [R.S.C., 1985, c. F-14]. The changes came into force on 21 June 2019 and the new provisions and strong protections better support the sustainability of Canada's fisheries resources while providing clearer permitting for development projects. Subsection 34.4(1) of the *Act* prohibits conducting a work, undertaking, or activity, other than fishing, that results in the death of fish. Subsection 35(1) of the *Act* prohibits conducting any work, undertaking, or activity that results in the harmful alteration, disruption, or destruction of fish habitat. Paragraphs 34.4(2)(b) and 35(2)(b) of the *Act* allow the Minister to issue an authorization with any terms and conditions in relation to a proposed work, undertaking, or activity that may, result in the death of fish or the harmful alteration, disruption or destruction of fish habitat.

A copy of the federal *Fisheries Act* can be found at:

<https://laws.justice.gc.ca/PDF/F-14.pdf>.

The water use reduction component of the Project will require work to be completed within the Saint John River and there will also be permanent infrastructure (*i.e.*, water intake) placed within the River. Work within the River and placement of that permanent infrastructure may require approval under the *Fisheries Act* (*n.b.*, the characteristics of the water intake structure, such as intake velocity, screen size, *etc.* will have to be provided to the DFO for review and approval). Submitting an application to the DFO will allow representatives to determine whether an authorization is required or not.

An applicant's guide to submitting a *Fisheries Act* Authorization application can be found at:

<https://www.dfo-mpo.gc.ca/pnw-ppe/reviews-revues/applicants-guide-candidats-eng.html>; and

an application for a *Fisheries Act* Authorization can be found at:

<https://www.dfo-mpo.gc.ca/pnw-ppe/reviews-revues/forms-formes/apply-auth-applique-eng.pdf>.

Contact information for the DFO is as follows:

Fisheries Protection Program
Fisheries and Oceans Canada
343 University Avenue
Moncton, New Brunswick
E1C 9B6

📞 506.851.2824

📠 506.851.6579

🌐 <http://www.dfo-mpo.gc.ca/fm-gp/peches-fisheries/index-eng.htm>

✉ gulflhabitatgolfe@dfo-mpo.gc.ca

6.1.2 Navigation Protection Permit

Any works that may affect navigable waters in Canada requires permit approval under the *Canadian Navigable Waters Act* [R.S.C., 1985, c. N-22]. The *Canadian Navigable Waters Act* and the *Navigable Waters Works Regulations* [C.R.C., c. 1232] are administered by Transport Canada and as per the Schedule of the *Act*, all Atlantic Ocean waters from the outer limit of the territorial sea up to the higher high water mean tide water level and includes all connecting waters up to an elevation intersecting with that level.

The cool water intake and a portion of the pipeline will be located within a scheduled navigable water. Water intakes can be classified as either minor or major works. With respect to this Project, it is believed that the cool water intake would be classified as a major works because the intake will extend vertically above the bed of the navigable water more than 5 % of the overall depth. Consultations with representatives from Transport Canada should be undertaken to confirm this.

A copy of the *Canadian Navigable Water Act* and the Schedule can be found at:

<<https://laws-lois.justice.gc.ca/PDF/N-22.pdf>>; and

a copy of the *Navigable Waters Works Regulations* can be found at:

<https://laws.justice.gc.ca/PDF/C.R.C.,_c._1232.pdf>; and

a copy of the application for approval under the Navigation Protection Program can be found at:

<<https://www.tc.gc.ca/eng/programs-623.html>>.

Contact information for the Atlantic Region Navigation Protection Program is as follows:

Navigation Protection Program
Atlantic Region – Maritimes
Transport Canada
95 Foundry Street, 6th Floor
PO Box 42
Moncton, New Brunswick
E1C 8K6

📞 506.851.3113

🌐 <http://www.tc.gc.ca>

✉️ NPPATL-PPNATL@tc.gc.ca

6.1.3 Navigational Warning

The *Canada Shipping Act, 2001* [S.C. 2001, c. 26] ensures safe marine navigation in Canadian waters. The regulatory framework under the *Act* establishes responsibilities for vessel traffic management, which is overseen by the Canadian Coast Guard. As per the regulatory framework, NAVigational WARNings (NAVWARNs) are notices regarding navigational aid changes or defects, fishing zones, military exercises, dredging, or other marine hazards. A NAVWARN is intended to inform the marine community of hazards,

current activities, and other pertinent information. There are two types of NAVWARNs: broadcast notices; and written notices. Broadcast notices are those that are of an urgent nature and are broadcast through Marine Communication and Traffic Services Centres (e.g., Sydney Marine Communications and Traffic Services, etc.). Written notices are those that are anticipated to remain in effect for an extended period of time as determined by the Regional Marine Information Centre.

A copy of the *Canada Shipping Act, 2001* can be found at:

<<https://laws-lois.justice.gc.ca/PDF/C-10.15.pdf>>; and

written NAVWARNs can be searched at:

<<https://nis.ccg-gcc.gc.ca/public/rest/messages/en/search>>.

Contact information for the Sydney Marine Communications and Traffic Services is as follows:

Sydney Marine Communications and
Traffic Services
1190 Westmount Road
Sydney, NS
B1R 2J6

📞 800.686.8676

🌐 <http://www.tc.gc.ca>

✉️ NotshipsSyd@dfo-mpo.gc.ca

There may be a requirement for a written NAVWARN to be submitted regarding the work; however, the requirement is at the discretion of the Regional Marine Information Centre. An announcement, such as that below, would then likely be posted on the NAVWARN website (i.e., see above). Personnel with the Sydney Marine Communications and Traffic Services Centre should be consulted regarding the requirement for a written NAVWARN.

Installation of a water intake structure is underway until further notice at Reversing Falls, Saint John County, N.B. in approximate position 45°15'38.4"N 65 5'25.8"W. Mariners are requested to exercise caution in this area.

6.1.4 Harbour Master Authorization

Pursuant to Section 6 and 12(1) of the *Canada Marine Act* [S.C. 1998, c. 10] the Saint John Port Authority manages the navigable waters of Saint John Harbour on behalf of the federal government. According to the Practices and Procedures of the Port, no marine construction can occur within Port Saint John until a full description of the project is submitted to the Harbour Master and only after authorization has been granted.

The cool water intake will be located in waters managed by PortSJ. Therefore, authorization will be required by the Harbour Master for the work to proceed.

A copy of the *Canada Marine Act* can be found at:

<<https://laws-lois.justice.gc.ca/PDF/C-6.7.pdf>>; and

a copy of the Saint John Port Authority's Practices and Procedures can be found at:

<<https://www.sjport.com/wp-content/uploads/2016/07/Saint-John-Port-Authority-Practices-and-Procedures-2015.pdf>>.

Contact information for Port Saint John is as follows:

Port Saint John
111 Water Street
Saint John, New Brunswick
E2L 0B1

📞 506.636.4869
📠 506.636.4443
🌐 <https://www.sjport.com/>
✉ port@sjport.com

6.2 PROVINCIAL APPROVALS

6.2.1 *Environmental Impact Assessment Approval*

As per Schedule A, item k) (*i.e.*, all facilities for the commercial processing or treatment of timber resources...) and item n) (*i.e.*, all sewage³ disposal or sewage treatment facilities, other than domestic, onsite facilities...) of the Environmental Impact Assessment Regulation [87-83] of the New Brunswick *Clean Environment Act* [R.S.N.B. 1973, c. C-6], the Project triggers EIA review. As previously noted, the purpose of an EIA is to identify and evaluate the potential impacts that the proposed Project will have on the environment. The EIA also identifies and presents measures to mitigate those potential environmental impacts. This EIA must also adhere to the Sector Guidelines for Wastewater Treatment Projects. The fee for registering this Project for EIA review is \$5 500.

A copy of the New Brunswick *Clean Environment Act* can be found at:

<<http://laws.gnb.ca/en/ShowPdf/cs/C-6.pdf>>;

a copy of the EIA Regulation can be found at:

<<http://laws.gnb.ca/en/ShowPdf/cr/87-83.pdf>>;

a copy of the EIA preparation guide can be found at:

<<https://www2.gnb.ca/content/dam/gnb/Departments/env/pdf/EIA-EIE/GuideEnvironmentalImpactAssessment.pdf>>;

³ The definition for sewage was repealed in 1993 and replaced with wastewater, which includes all industrial wastewater or domestic wastewater, whether treated or untreated, containing human, animal, vegetable, or mineral matter in liquid or solid form, in suspension or in solution.

a copy of the EIA fee guide can be found at:

<<https://www.pxw1.snb.ca/snb9000/product.aspx?productid=A001P809000>>; and

a copy of the Sector Guidelines can be found at:

<<https://www2.gnb.ca/content/dam/gnb/Departments/env/pdf/EIA-EIE/SectorGuidelines/WastewaterTreatment.pdf>>.

Contact information for the NBDELG's Environmental Assessment Section of the Sustainable Development and Impact Evaluation Branch is as follows:

NBDELG
Environmental Assessment
Sustainable Development and Impact Evaluation
PO Box 6000
Fredericton, NB
E3B 5H1

📞 506.444.5382
📠 506.453.2627
🌐 www.gnb.ca/environment
✉ eia-eie@gnb.ca

6.2.2 *Environmental Protection Plan*

Because an EIA is triggered, a Project-specific EPP will need to be developed for this Project. The EPP will be an important component to the overall Project because it will dictate the importance of BMPs that shall be undertaken by all those associated with the Project to ensure environmental protection. The EPP will provide a practical means for conveying BMPs to IPP for ensuring the implementation of the outlined standards and regulations throughout the entire Project. It will be a dynamic document to be used by Project personnel in the field and at the corporate level for ensuring BMPs are implemented and monitored.

More specifically, the purpose of the EPP will be to:

- outline IPP's commitments to minimize potential Project environmental impacts;
- comply with the conditions of any authorization(s), license(s), and / or permit(s) issued to complete the Project;
- provide a reference document for IPP and all contractor personnel to use when planning and / or conducting specific Project activities; and
- provide a summary of environmental issues and protection measures to be implemented during the Project.

The EPP should be developed in accordance with applicable federal and provincial environmental protection legislation and regulations. IPP should take a proactive approach toward creating a safe and secure work environment and maintain a system to manage environmental effects of the Project. In doing so, they should identify health, safety, environmental, and security issues as part of the execution planning and manage the environmental effects of the Project and work in ways that are environmentally,

economically, and socially justified and legally compliant. Specific health, environmental, safety, and security issues should be addressed in the execution plans and procedures for the Project.

Development of an EPP document is often a requirement for many of the approvals required because it demonstrates impact mitigation. A Project-specific EPP will be developed during detailed engineering design. When complete, the EPP will be submitted to the NBDELG for review. EPPs have been developed for other EIA approved work at the Mill, such as the chip digester, which was completed in 2016, the new pulp dryer currently under construction, and for other projects, such as the infilling at Lee Cove.

Some of the datasheets that will most likely be included in the Project-specific EPP are:

- aquatic flora and fauna protection;
- archaeological discovery;
- concrete wash water management;
- environmental incidents reporting guidelines;
- hazardous materials management;
- pile driving sound emissions;
- rock check dams;
- sanitary waste management;
- sediment filter bag; sediment traps;
- silt fences;
- solid waste management;
- spill prevention and control;
- spills or leaks emergency response procedures;
- stockpile management;
- storm drain inlet protection;
- straw bale barriers;
- terrestrial flora and fauna protection;
- vehicle and equipment cleaning;
- vehicle and equipment fueling;
- and vehicle and equipment maintenance.

Details regarding the management of surface water runoff / drainage will also be included within the EPP document.

6.2.3 *Watercourse and Wetland Alteration Permit*

New Brunswick's watercourses and wetlands are afforded protection under the Watercourse And Wetland Alteration (WAWA) Regulation [90-80] of the New Brunswick *Clean Water Act* [S.N.B. 1989, c. C-6.1]. Any proposed alterations within watercourses and / or wetlands, or within their 30 m regulated buffer, require permitting through the NBDELG's WAWA program. There will be instances when work will be required within 30 m of the Saint John River (*i.e.*, installing effluent piping, installing the cooling water pumphouse, and installing the cooling water pipeline) and within the Saint John River at

Reversing Falls (*i.e.*, installing the cool water intake). That work can only be done through authorization under a WAWA permit.

A copy of the New Brunswick *Clean Water Act* can be found at:

<<http://laws.gnb.ca/en/ShowPdf/cs/C-6.1.pdf>>;

a copy of the WAWA Regulation can be found at:

<<http://laws.gnb.ca/en/ShowPdf/cr/90-80.pdf>>;

the WAWA application portal can be found at:

<<https://www.elgegl.gnb.ca/WAWAG/en/Home/Site>>; and

a copy of the WAWA technical guidelines can be found at:

<<https://www2.gnb.ca/content/dam/gnb/Departments/env/pdf/Water-Eau/WatercourseWetlandAlterationTechnicalGuidelines.pdf>>.

Contact information for the NBDELG WAWA program is as follows:

NBDELG
Surface Water Protection
Sustainable Development and Impact Evaluation
Marysville Place
PO Box 6000
Fredericton, NB
E3B 5H1

📞 506.457.4850

📠 506.453.6862

🌐 <http://www2.gnb.ca/content/gnb/en/departments/elg/environment.html>

✉ elg/egl-info@gnb.ca

6.2.4 Approval To Construct

The Water Quality Regulation [82-126] of the New Brunswick *Clean Environment Act* [R.S.N.B. 1973, c. C-6] requires owners and / or operators of a facility that releases a contaminant to the water environment to apply for the construction of the source. Construction of the Project may only commence after an Approval To Construct (ATC) has been issued by the NBDELG Minister and construction must be done in accordance with the terms and conditions imposed on the approval issued for that source.

A copy of the *Clean Environment Act* can be found at:

<<http://laws.gnb.ca/en/ShowPdf/cs/C-6.pdf>>;

a copy of the Water Quality Regulation can be found at:

<<http://laws.gnb.ca/en/ShowPdf/cr/82-126.pdf>>;

Contact information for the Authorizations and Compliance Division of the NBDELG is as follows:

NBDELG
 Authorizations and Compliance
 Permitting South
 Marysville Place
 PO Box 6000
 Fredericton, NB
 E3B 5H1

📞 506.453.7945

📠 506.453.2390

🌐 <http://www2.gnb.ca/content/gnb/en/departments/elg/environment.html>

✉ elg@egl-info@gnb.ca

6.2.5 Approval To Operate

6.2.5.1 Water Quality

As per the Water Quality Regulation [82-126] of the New Brunswick *Clean Environment Act* [R.S.N.B. 1973, c. C-6], a Class 1A ATO was issued to IPP for operation of the Reversing Falls Mill. That ATO (*i.e.*, I-11284) was issued on 1 May 2021 and is valid through 30 May 2024 (*i.e.*, refer to Appendix II). That ATO will have to be modified to include operation of the ETF. Links to the Act and Regulation and contact information for the NBDELG Authorizations and Compliance Division are included in Section 6.2.4.

6.2.6 Vehicle Dimensions and Mass and Special Permit Fees

The sizing of vehicles and their loadings on roadways in the Province is controlled under the Vehicle Dimensions and Mass Regulation [2001-67] of the *Motor Vehicle Act* [R.S.N.B. 1973, c. M-17]. All trucks used for the Project must adhere to the legal load weights limits at all times, including spring weight restrictions. If a truck exceeds dimensions and / or mass for a roadway, then there is a requirement to obtain permission under the Special Permit Fees Regulation [89-65] of the *Act*. It is likely that vehicles exceeding weight or dimension limits on a public roadway will be required for delivering large Project components so a permit may be required.

A copy of the *Motor Vehicle Act* can be found at:

<<http://laws.gnb.ca/en/ShowPdf/cs/M-17.pdf>>;

a copy of the Vehicle Dimensions and Mass Regulation can be found at:

<<http://laws.gnb.ca/en/ShowPdf/cr/2001-67.pdf>>;

a copy of the Special Permit Fees Regulation can be found at:

<<http://laws.gnb.ca/en/ShowPdf/cr/89-65.pdf>>; and

an application for a Special Permit can be found at:

<https://www.pxw1.snb.ca/snb9000/product.aspx?ProductID=A001PTI023a>.

Contact information for the New Brunswick Department of Transportation and Infrastructure (NBDTI) Saint John district office is as follows:

NBDTI
Saint John District Office
50 Crown Street, Suite 105
Saint John, NB
E2L 2X6

📞 506.643.7463

📠 506.643.7464

🌐 https://www2.gnb.ca/content/gnb/en/departments/dti/district_offices.html

✉ transportation.web@gnb.ca

6.2.7 *Electrical Plan Approval and Wiring Permit*

As per the General Regulation [84-165] and the Lightning Protection System Regulation [82-215] of the New Brunswick *Electrical Installation and Inspection Act* [R.S.N.B. 2011, c. 144], a plan review is required for electrical installations in excess of 600 amps at 120 / 240 volts, 400 amps at 120 / 208 volts, 400 amps at 347 / 600 volts and for any installation having a voltage in excess of 600 volts. A plan approval must be completed before a wiring permit can be issued. The plan review and wiring permit are obtained from the New Brunswick Department of Justice and Public Safety (NBDJPS). Review of the preliminary design drawings for the Project indicates that there will be electrical installations that trigger an electrical plan approval and wiring permit from the Province.

A copy of the *Electrical Installation and Inspection Act* can be found at:

<http://laws.gnb.ca/en/showpdf/cs/2011-c.144.pdf>;

a copy of the Lightning Protection System Regulation can be found at:

<http://laws.gnb.ca/en/showpdf/cr/82-215.pdf>; and

a copy of the General Regulation can be found at:

<http://laws.gnb.ca/en/showpdf/cr/84-165.pdf>.

Contact information for the regional office for technical inspection services is as follows:

NBDJPS
Regional Office - Saint John
Technical Inspection Services
8 Castle Street
PO Box 5001
Saint John, NB
E2L 4Y9

- 📞 506.658.2510
- 📠 506.658.2767
- 🌐 http://www2.gnb.ca/content/gnb/en/departments/public_safety.html
- ✉️ DPS-MSP.information@gnb.ca

6.3 MUNICIPAL APPROVALS

6.3.1 Re-Zoning

As per Part 3, Division C of the New Brunswick *Community Planning Act* [S.N.B. 2017, c.19], the City of Saint John, upon the adoption of a municipal plan, shall enact a Zoning By-Law. On 15 December 2014, ZoneSJ (*i.e.*, the Zoning By-Law of the City of Saint John) was enacted. The Zoning By-Law [C.P. 111] prescribes the use, placement, erection, and / or alteration of land, buildings, or structures within specific zones within the City. A zoning by-law amendment (*i.e.*, re-zoning) is required when a proposed use does not conform to the stipulated zoning. Re-zoning applications are administered through the *City of Saint John One-Stop Development Shop*.

A copy of the New Brunswick *Community Planning Act* can be found at:

<<http://laws.gnb.ca/en/ShowPdf/cs/2017-c.19.pdf>>; and

a copy of the City of Saint John Zoning By-Law can be found at:

<<https://saintjohn.ca/sites/default/files/2021-02/Zoning%20By-Law.pdf>>.

Contact information for the *City of Saint John One-Stop Development Shop* is as follows:

Growth & Community Development Services
 One Stop Development Shop
 Ground Floor, City Hall
 15 Market Square
 PO Box 1971
 Saint John, NB
 E2L 4L1

- 📞 506.658.2911
- 🌐 <https://saintjohn.ca/en/city-hall/city-corporation/rates-and-finances/one-stop-development-shop>
- ✉️ onestop@saintjohn.ca

The Project's properties are zoned Heavy Industrial. The City of Saint John's Zoning By-Law specifies that *Wastewater Treatment Plants* are to be located on properties zoned Utility Service (Table 79). It is believed that Wastewater in that instance refers to municipal wastewater. Because the ETF is strictly for treating effluent from a heavy industrial facility, the current zoning is most likely appropriate and will not have to be rezoned. Representatives with the City of Saint John should be contacted to confirm. It is worth noting that Irving Paper's aerated stabilization basin in east Saint John that treats effluent from the manufacturing of paper is located on a property that is zoned Heavy Industrial and not Utility Service.

Table 79. Permitted uses based on zoning in the City of Saint John, New Brunswick.

Zone	Permitted Uses*
Heavy Industrial (IH)	Air transport facility; Asphalt plant; Auction facility; Bulk fuel storage depot; Cement plant; Concrete plant; Electrical generation station; General contractor service; Harbour facility; Heavy industrial use; Marshalling yard; Medium industrial use; Outdoor storage; Recycling depot; Scrap or salvage yard; Industrial service and repair; Towing service; Transportation depot; Transportation terminal
Utility Service (US)	Government or utility works department; Library; Major utility distribution structure; Wastewater treatment facility; and Water treatment facility

Notes:

From The City of Saint John Zoning By-law 2014, Office Consolidation 31 October 2016

6.3.2 Building Permit

Pursuant to Part 4, Division B of the New Brunswick *Community Planning Act* [**S.N.B. 2017, c.19**], a building permit must be obtained prior to the construction, relocation, demolition, and / or altering of any structures on land within a municipality. Building Permits in Saint John are administered through the *City of Saint John One-Stop Development Shop*.

A copy of the New Brunswick *Community Planning Act* can be found at:

<http://laws.gnb.ca/en/ShowPdf/cs/2017-c.19.pdf>; and

an application for a building permit can be found at:

<https://saintjohn.ca/sites/default/files/2020-12/6%20New%20Construction%20Part%209%20Submission%20Package.pdf>.

Contact information for the *City of Saint John One-Stop Development Shop* is provided in Section 6.3.1.

A building permit will be required to build any structures (e.g., buildings, tanks, etc.) associated with the Project within Saint John's municipal boundaries.

6.3.3 Excavation Permit

As per the New Brunswick *Community Planning Act* [**S.N.B. 2017, c.19**] and the Zoning By-Law of the City of Saint John [**C.P. 111**], an excavation permit is required to excavate land within the municipality. The permit is administered through the *City of Saint John One-Stop Development Shop*.

A copy of the New Brunswick *Community Planning Act* can be found at:

<http://laws.gnb.ca/en/ShowPdf/cs/2017-c.19.pdf>;

a copy of the City of Saint John Zoning By-Law can be found at:

<<https://saintjohn.ca/sites/default/files/2021-02/Zoning%20By-Law.pdf>>; and

a City of Saint John Excavation Permit application form can be found at:

<<https://saintjohn.ca/sites/default/files/2020-12/6%20New%20Construction%20Part%209%20Submission%20Package.pdf>>.

Contact information for the *City of Saint John One-Stop Development Shop* is provided in Section 6.3.1.

Excavations required for access road construction, foundations, and bedrock removal may require the Proponent to obtain an excavation permit from the City of Saint John; however, consultations with City representatives will have to be done to confirm this.

7.0 FUNDING

The capital cost for this Project is estimated at \$150 million. The Project will be solely funded by Irving Pulp & Paper, Limited. No provincial or federal monies are being used for this Project.

8.0 SIGNATURES

This Project Environmental Impact Assessment was prepared in accordance with the Environmental Impact Assessment Regulation [87-83] under the New Brunswick *Clean Environment Act* [R.S.N.B. 1973, c. C-6] and on the advice of and in consultation with the various Regulators. Fundy Engineering & Consulting Ltd. prepared the document on behalf of Irving Pulp & Paper, Limited. The Proponent has reviewed the document and understands the information contained within.

Respectfully submitted,

Proponent Signature:



**Ms. Renée Morais, P.Eng.
Director of Environment
J.D. Irving Limited**

Environmental Consultant Signature:



**Dr. Matt Alexander, P.Geo., FGC, EP
Environmental Scientist
Fundy Engineering & Consulting Ltd.**

17 March 2022

9.0 REFERENCES

Below is a list of reference documents that were used to prepare this EIA document. Any and all of these documents are available to the TRC upon request.

Bindoff, N.L., J. Willebrand, V. Artale, A. Cazenave, J. Gregory, S. Gulev, K. Hanawa, C. Le Quéré, S. Levitus, Y. Nojiri, C.K. Shum, L.D. Talley, and A. Unnikrishnan. 2007. Observations: Oceanic Climate Change and Sea Level. In Solomon, S., D. Qin, M. Manning, Z. Chen, M. Marquis, K.B. Averyt, M. Tignor and H.L. Miller [editors]. Climate Change 2007: The Physical Science Basis. Contribution of Working Group I to the Fourth Assessment Report of the Intergovernmental Panel on Climate Change. Cambridge University Press, New York. A copy of the document was obtained online at:

https://www.ipcc.ch/site/assets/uploads/2018/05/ar4_wg1_full_report-1.pdf

Bruce, J., I. Burton, H. Martin, B. Mills, and L. Mortsch. 2000. Water sector: vulnerability and adaptation to climate change, background paper for regional workshop, November 19, 2000. Global Change Strategies International Inc. and Atmospheric Environment Science, Environment Canada.

https://www.researchgate.net/profile/Linda_Mortsch/publication/2410938_Water_Sector_Vulnerability_and_Adaptation_to_Climate_Change/links/555bc74408ae91e75e7668d3/Water-Sector-Vulnerability-and-Adaptation-to-Climate-Change.pdf?origin=publication_detail

Brundtland, G.H. 1987. Report of the World Commission on Environment and Development: Our Common Future. 300p. A copy of the document was obtained online at:

<https://sustainabledevelopment.un.org/content/documents/5987our-common-future.pdf>

Campbell, R. 1788. A map of the Great River St. John & Waters, the first ever published from the Bay of Fundy up to St. Anns of Frederick's Town. From a survey completed in 1784 through 1787 by Robert Campbell, surveyor and Captain of the 40th Company of the St. John's Loyalists.

Canadian Broadcasting Corporation (CBC). 2016. Artifacts found near Saint John museum may be 4,400 years old. A copy of the document was obtained online at:

<https://www.cbc.ca/news/canada/new-brunswick/saint-john-museum-artifacts-1.3395000>

Canadian Council of Ministers of the Environment (CCME). 2013. 2010-2011 progress report on The Canada-Wide Acid Rain Strategy for Post-2000. 41p. A copy of the document was obtained online at:

https://publications.gc.ca/collections/collection_2013/ccme/En108-1-5-2011-eng.pdf

Canadian Environmental Assessment Agency. 2003. *Incorporating climate change considerations in environmental assessment: general guidance for practitioners*. The Federal-Provincial-Territorial Committee on Climate Change and Environmental Assessment. A copy of the document was obtained online at:

<https://www.canada.ca/content/dam/iaac-acei/documents/policy-guidance/incorporating-climate-change-considerations-environmental-assessment-general-guidance-practitioners/incorporating-climate-change-considerations-environmental-assessment.pdf>

Canadian Rivers Institute (CRI). 2011. The Saint John River: a state of the environment report. 183p. A copy of the document was obtained online at:

<https://static1.squarespace.com/static/5c4f36c48ab722f1b25a301b/t/5c7f1c58e5e5f035147d3fa2/1551834215283/St.%2BJohn%2Briver%2Breport1-min.pdf>

Carey, J. 2012. Storm warnings: extreme weather is a product of climate change. Scientific American, In-Depth Reports on Extreme Weather and Climate Change, Energy & Sustainability. A copy of the document was obtained online at:

<http://www.scientificamerican.com/article/extreme-weather-caused-by-climate-change/>

- Committee On the Status of Endangered Wildlife In Canada (COSEWIC). 2021. Species profiles. Information was obtained online at:
http://www.cosewic.gc.ca/eng/sct0/index_e.cfm
- Council on Environmental Quality (CEQ). 2021. A citizen's guide to the NEPA, having your voice heard. Executive Office of the President. 37p. A copy of the document was obtained online at:
<https://ceq.doe.gov/docs/get-involved/citizens-guide-to-nepa-2021.pdf>
- Coutant, C.C. 2021. Why cylindrical screens in the Columbia River (USA) entrain few fish. *Journal of Ecohydraulics*. 12p. A copy of the document was obtained online at:
<https://www.tandfonline.com/doi/full/10.1080/24705357.2020.1837023>
- Craig, J.R., D.J. Vaughan, and B.J. Skinner. 1996. *Resources of the earth: origin, use, and environmental impact, second edition*. Prentice-Hall, Inc.: Upper Saddle River. 472p.
- Daigle, R. 2020. Updated sea-level rise and flooding estimates for New Brunswick coastal sections 2020 based on IPCC 5th assessment report. 81p. A copy of the report was obtained online at:
<https://www2.gnb.ca/content/dam/gnb/Departments/env/pdf/Flooding-Inondations/SeaLevelRiseAndFloodingEstimates2020.pdf>
- Dee, N., J. Baker, N. Drobny, K. Duke, I. Whitman, and D. Fahringer. 1973. An environmental evaluation system for water resource planning. *Water Resources Research*, 9(3): 523-535.
- Department of Fisheries and Oceans (DFO). 1995. Freshwater intake end-of-pipe fish screen guideline. Fs 23-270 / 1995E. 34p. The data were accessed online at:
<https://publications.gc.ca/collections/Collection/Fs23-270-2004E.pdf>
- Department of Fisheries and Oceans (DFO). 2021a. Seven Day Tidal Predictions. The data were accessed online at:
<https://www.tides.gc.ca/eng/station?sid=65>
- Department of Fisheries and Oceans (DFO). 2021b. Station Inventory Data, Station 65 Saint John. The data were accessed online at:
<https://www.meds-sdmm.dfo-mpo.gc.ca/isdm-gdsi/twl-mne/inventory-inventaire/interval-intervalle-eng.asp?user=isdm-gdsi®ion=ATL&lst=1&no=65>
- Environment Canada. 2006. Impacts of sea level rise and climate change on the coastal zone of southeastern New Brunswick. A copy of the document was obtained online at:
<https://publications.gc.ca/collections/Collection/En84-45-2006E.pdf>
- Environment and Climate Change Canada (ECCC). 2017. Proposed modernization of the pulp and paper effluent regulations – consultation document. 4p. A copy of the document was obtained online at:
http://www.google.ca/url?sa=t&rct=j&q=&esrc=s&source=web&cd=1&cad=rja&uact=8&ved=0ahUKEwiU0fqLjd_XAhWFw4MKH_eFAowQFqgmMAA&url=http%3A%2F%2Fwww.nben.ca%2Fen%2Fmarine-fisheries-aquaculture%3Fdownload%3D5045%3Aproposed-modernization-of-the-pulp-and-paper-effluent-regulations-consultation-document-environment-and-climate-change-canada-september-2017&usq=AOvVaw0dCuR0n-zSm-csx16QxBJE
- Environment and Climate Change Canada (ECCC). 2019. Modernization of the pulp and paper effluent regulations – detailed proposal for consultation. 17p. A copy of the document was obtained online at:
<https://www.canada.ca/en/environment-climate-change/services/managing-pollution/effluent-regulations-fisheries-act/consultation-modernization-pulp-paper-effluent-regulations/detailed-proposal-consultation-may-2019.html>
- Environment and Climate Change Canada (ECCC). 2021a. Canadian climate normals. Data for the Saint John A weather station (Saint John Airport). The data were obtained online at:

https://climate.weather.gc.ca/climate_normals/results_e.html?searchType=stnName&txtStationName=saint-john&searchMethod=contains&txtCentralLatMin=0&txtCentralLatSec=0&txtCentralLongMin=0&txtCentralLongSec=0&stnID=6250&dispBack=1&month1=0&month2=12

Environment and Climate Change Canada (ECCC). 2021b. Greenhouse gas emissions: inventories and reporting. The data were obtained online at:

<https://www.canada.ca/en/environment-climate-change/services/climate-change/greenhouse-gas-emissions.html>

Environment and Climate Change Canada (ECCC). 2021c. Real-time hydrometric data. The data were obtained online at:

https://wateroffice.ec.gc.ca/mainmenu/real_time_data_index_e.html

Environment and Climate Change Canada (ECCC). 2021d. Air pollutants emissions inventory online search. The data were obtained online at:

<https://pollution-waste.canada.ca/air-emission-inventory>

Environment and Sustainable Development Research Centre (ESCRC). 2010. Climate change scenarios New Brunswick municipalities. ETF Project Number 09-0218.

Environmental Law Institute (ELI). 2010. NEPA success stories: celebrating 40 years of transparency and open government. 42p. A copy of the document was obtained online at:

<http://www.eli.org/sites/default/files/eli-pubs/d20-03.pdf>

Ernst and Young (EY). 2020. City of Saint John operational review, final report. A copy of the document was obtained online at:

<https://saintjohn.ca/sites/default/files/2020-11/City%20of%20Saint%20John%20-%20Operational%20Review%20Final%20Report%20March%2031%202020...pdf>

Fedorenko, A. Y. 1991. Guidelines for minimizing entrainment and impingement of aquatic organisms at marine intakes in British Columbia. Canadian Manuscript Report of Fisheries and Aquatic Sciences 2098. 95p. A copy of the document was obtained online at:

https://publications.gc.ca/collections/collection_2007/dfo-mpo/Fs97-4-2098E.pdf

Filion, F.L., E. DuWors, A. Jacquemot, P. Bouchard, P. Boxall, P.A. Gray, and R. Reid. 1989. The importance of wildlife to Canadians in 1987: Highlights of a national survey. Federal-Provincial Task, Canadian Wildlife Service. 47p.

<http://a100.gov.bc.ca/pub/eirs/viewDocumentDetail.do?fromStatic=true&repository=BDP&documentId=3701>

Forest NB. 2016. New Brunswick forest industry, economic impact. A copy of the document was obtained online at:

<https://www.forestnb.com/wp-content/uploads/2018/03/1FNB-Presentation-Mar2018-1.pdf>

Francis, D. and H. Hengeveld. 1998. Extreme weather and climate change. Environment Canada Climate and Water Products Division. 35p. A copy of the document was obtained online at:

https://publications.gc.ca/collections/collection_2018/eccc/En57-27-1998-01-eng.pdf

Fundy Engineering. 2017. Proposed wastewater treatment plant, environmental permitting roadmap, Irving Pulp & Paper, Limited Reversing Falls Mill. 74p.

Fundy Engineering. 2014. Chip handling and continuous cooking digester plant renewal, archaeological resources supplement. 26p.

Geological Survey of Canada. 2021. *Earthquake zones in Eastern Canada*. A copy of the document was obtained online at:

<http://www.earthquakescanada.nrcan.gc.ca/zones/eastcan-eng.php#NASZ>

- Goyal, S.K. and V.A. Deshpande. 2001. Comparison of weight assignment procedures in evaluation of environmental impacts. *Environmental Impact Assessment Review*, 21: 553-563.
- Gray, P.A., P. Boxall, R. Reid, F.L. Fillion, E. DuWors, A. Jacquemont, P. Bouchard, and A. Bath. 1993. The importance of wildlife to Canadians: results from three national surveys. In I.D. Thompson [editor], *Forests and wildlife...towards the 21st century*, Proceedings of the International Union of Game Biologists XXI Congress, 15 to 20 August 1993, Halifax. p. 151-157. A copy of the document was obtained online at: <https://d1ied5g1xfqpx8.cloudfront.net/pdfs/19075.pdf>
- Health Canada. 1998. The health and environment handbook for health professionals: health and environment. 180p. A copy of the document was obtained online at: <https://publications.gc.ca/site/eng/9.695394/publication.html>
- Henry, J.G. and G.W. Heinke. 1996. *Environmental science and engineering*, 2nd edition. Prentice Hall Inc.: Upper Saddle River. 778p.
- Henton, J.A., M.R. Craymer, R. Ferland, H. Dragert, S. Mazzotti, and D.L. Forbes. 2006. Crustal motion and deformation monitoring of the Canadian landmass. *Geomatica*, 60 (2): 173-191.
- Hinds, H.R. 2000. *Flora of New Brunswick*, 2nd edition. Biology Department, University of New Brunswick: Fredericton.
- Hughes Clarke, J.E. 2000. Kennebecasis-Grand Bay sill, a view of the salt and fresh water exchange in the lower St. John River. A copy of the document was obtained online at: http://www.omg.unb.ca/GGE/Sill_Survey.html
- Institute for Catastrophic Loss Reduction (ICLR). 2012. Telling the weather story. Report prepared for the Insurance Bureau of Canada. A copy of the document was obtained online at: http://assets.ibc.ca/Documents/Studies/McBean_Report.pdf
- Intergovernmental Panel on Climate Change (IPCC). 2013. *Working group I contribution to the IPCC fifth assessment report climate change 2013: the physical science basis summary for policy makers*.
- Intergovernmental Panel on Climate Change (IPCC). 2021. *Working group I contribution to the sixth assessment report of the intergovernmental panel on climate change: climate change 2021, the physical science basis summary for policy makers*. A copy of the document was obtained online at: https://www.ipcc.ch/report/ar6/wg1/downloads/report/IPCC_AR6_WGI_SPM.pdf
- International Association for Impact Assessment and the Institute of Environmental Management and Assessment (IAIA & IEMA). 1999. Principles of EIA best practice. IAIA, Fargo, North Dakota. 4p. A copy of the document was obtained online at: https://www.iaia.org/uploads/pdf/principlesEA_1.pdf
- International Joint Commission (IJC). 2020. Canada – United States air quality agreement progress report 2018. 37p. A copy of the document was obtained online at: https://publications.gc.ca/collections/collection_2020/eccc/En85-1-2018-eng.pdf
- Johnson, S.C., M.J. McLeod, S.M. Barr, and C.E. White. 2005. Bedrock geology of the Saint John area (NTS 21 G/08), Saint John, Kings, Queens, and Charlotte Counties, New Brunswick. New Brunswick Department of Natural Resources; Minerals, Policy, and Planning Division. Plate 2005-31.
- Kidd, S.D., R.A. Curry, and K.R. Munkittrick. 2011. The Saint John River: a state of the environment report. A publication of the Canadian Rivers Institute. 183p. A copy of the document was obtained online at: https://www.unb.ca/research/institutes/cri_resources/pdfs/criday2011/cri_sjr_so_e_final.pdf

- Koeller, P., L. Savard, D.G. Parsons, and C. Fu. 2000. A precautionary approach to assessment and management of shrimp stocks in the Northwest Atlantic. *Journal of Northwest Atlantic Fishery Science*, 27: 235-246.
- Lamontagne, M., S. Halchuk, J.F. Cassidy, and G.C. Rogers. 2018. Significant Canadian Earthquakes 1600-2017. Geological Survey of Canada, Open File 8285. 37p. A copy of the document was obtained online at:
<https://geoscan.nrcan.gc.ca/starweb/geoscan/servlet.starweb?path=geoscan/download.web&search1=R=311183>
- Langmuir, D. 1997. *Aqueous environmental geochemistry*. Prentice-Hall, Inc.: Upper Saddle River. 600p.
- Leopold, L.B., F.E. Clarke, B.B. Hanshaw, and J.E. Balsley. 1971. A procedure for evaluating environmental impact. *U.S. Geological Survey Circular*, 645. 16p.
- Lewis, P.J. 1997. Climate trends in Atlantic Canada. In *Climate change and climate variability in Atlantic Canada*, R.W. Shaw [editors]; Environment Canada, Atlantic Region, Occasional Paper 9, p. 180-183.
<http://publications.gc.ca/collections/Collection/En56-119-4-1997E.pdf>
- Lines, G.S., M. Pancura and C. Lander. 2006. Building climate change scenarios of temperature and precipitation in Atlantic Canada using the statistical downscaling model (SDSM). Climate Change Division, Meteorological Service of Canada, Atlantic Region. 41p. A copy of the document was obtained online at:
https://climatechange.novascotia.ca/sites/default/files/uploads/Building_Climate_Scenarios.pdf
- Lutgens, F.K. and E.J. Tarbuck. 2001. *The atmosphere: an introduction to meteorology*, eighth edition. Prentice-Hall, Inc.: Upper Saddle River. 484p.
- McCubbin Consultants (N. McCubbin Consultants Inc.). 2015. Comments on NS 2011-076657-R03. Wastewater treatment at Northern Pulp Nova Scotia. 16p. A copy of the document was obtained online at:
<http://northernpulp.ca/assets/Industrial-Approval/NeilMcCubbin-memo.pdf>
- Metcalf, C.D., M.J. Dadswell, G.F. Gillis, and M.L.H. Thomas. 1976. Physical, chemical, and biological parameters of the Saint John River Estuary, New Brunswick, Canada. Environment Canada and Fisheries and Marine Service, Technical Report 686. 44p. A copy of the document was obtained online at:
<https://waves-vagues.dfo-mpo.gc.ca/Library/16702.pdf>
- Meteorological Service of Canada. 2004. Canadian acid deposition science assessment: summary of key results. 65p.
- Murphy, B. and D. Nance. 1998. *Earth science today*. Brooks / Cole • Wadsworth: Toronto. 684p.
- National Pollutant Release Inventory (NPRI). 2021. NPRI data search. The data were obtained online at:
<https://open.canada.ca/data/en/dataset/1fb7d8d4-7713-4ec6-b957-4a882a84fed3>
- NatCatSERVICE. 2019. Natural loss events worldwide 1980 – 2019, number of events. Münchener Rückversicherungs-Gesellschaft, Geo Risks Research as at December 2019. The data were obtained online at:
<https://www.munichre.com/en/risks/natural-disasters-losses-are-trending-upwards.html>
- Natural Resources Canada. 2005. *The atlas of Canada – groundwater distribution*. A copy of the document was obtained online at:
<http://atlas.gc.ca/site/english/maps/freshwater/distribution/groundwater>
- Natural Resources Canada. 2021. 2015 National Building Code of Canada seismic hazard maps. A copy of the maps was obtained online at:

- <http://www.seismescanada.rncan.gc.ca/hazard-alea/zoning-zonage/NBCC2015maps-en.php>
- New Brunswick Aboriginal Affairs Secretariat (NBAAS). 2011. Government of New Brunswick duty to consult. 12p. A copy of the document was obtained online at:
<https://www2.gnb.ca/content/dam/gnb/Departments/aas-saa/pdf/en/DutytoConsultPolicy.pdf>
- New Brunswick Department of Aboriginal Affairs (NBDAA). 2019. A guide for proponents on engaging with Aboriginal Peoples in New Brunswick. A copy of the document was obtained online at:
<https://www2.gnb.ca/content/dam/gnb/Departments/aas-saa/pdf/ProponentGuide-Excel/InterimProponentGuide.pdf>
- New Brunswick Department of the Environment and Local Government (NBDELG). 2021. Irving Pulp & Paper Limited Les Pâtes & Papier Irving, Limitée, Reversing Falls Mill Complex, Saint John, New Brunswick. A copy of the document was obtained online at:
<https://www2.gnb.ca/content/dam/gnb/Departments/env/pdf/Air-Lair/Class-Categorie1/IrvingPulpPaper/facility-profile.pdf>
- New Brunswick Department of the Environment and Local Government (NBDELG). 2018. A guide to environmental impact assessment in New Brunswick. A copy of the document was obtained online at:
<https://www2.gnb.ca/content/dam/gnb/Departments/env/pdf/EIA-EIE/GuideEnvironmentalImpactAssessment.pdf>
- New Brunswick Department of the Environment and Local Government (NBDELG). 2004. Additional Information Requirements for Wastewater Treatment Projects. A copy of the document was obtained online at:
<https://www2.gnb.ca/content/dam/gnb/Departments/env/pdf/EIA-EIE/SectorGuidelines/WastewaterTreatment.pdf>
- New Brunswick Department of Post-Secondary Education, Training, and Labour (NBDPSETL). 2013. New Brunswick regional profile: southwest. A copy of the document was obtained online at:
http://www2.gnb.ca/content/dam/gnb/Departments/pett-epft/PDF/Publications/NBRP3_Southwest.pdf
- New Brunswick Department of Post-Secondary Education, Training, and Labour (NBDPSETL). 2018. New Brunswick regional profile: southwest. A copy of the document was obtained online at:
<https://www.nbjobs.ca/sites/default/files/pdf/2018-11-26-southwestregionalprofile-en.pdf>
- Office of the Deputy Prime Minister (ODPM). 2002. Draft guidance on the strategic environmental assessment directive. Proposals for practice guidance on applying Directive 2001/42/EC "on the assessment of the effects of certain plans and programmes on the environment" to land use and spatial plans in England.
- Parkes, G.S., D.L. Forbes, and L.A. Ketch. 2006. Sea-level rise and regional subsidence in southeastern New Brunswick. *In* Impacts of sea level rise and climate change on the coastal zone of southeastern New Brunswick, R. Daigle, D. Forbes, G. Parkes, H. Rit, T. Webster, D. Berube, A. Hanson, L. DeBaie, S. Nichols, and L. Vasseur [editors]; Environment Canada, 613 p. The document can be obtained online at:
<http://www.gulfmaine.org/2/wp-content/uploads/2014/03/NewBrunswickSeaLevelRise.pdf>
- Pawling, M.A. 2017. Wəlastəkwey (Maliseet) homeland: waterscapes and continuity within the Lower St. John River Valley, 1784-1900. *Acadiensis* XLVI, no. 2 (Summer/Autumn 2017): 5-34. A copy of the document was obtained online at:
<https://journals.lib.unb.ca/index.php/acadiensis/article/view/25946/30150>
- Peel, M.C., B.L. Finlayson, and T.A. McMahon. 2007. Updated world map of the Köppen-Geiger climate classification. *Hydrol. Earth Syst. Sci.*, 11: 1633-1644.
- Port Saint John (PSJ). 2020. Rising to the challenge, 2020 annual report. A copy of the document was obtained online at:
https://www.sjport.com/wp-content/uploads/2021/05/SJP_annualreport2021_english-FINAL.pdf

Province of New Brunswick (PNB). 2016. Transitioning to a low-carbon economy, New Brunswick's climate change action plan. A copy of the document was obtained online at:

<https://www2.gnb.ca/content/dam/gnb/Departments/env/pdf/Climate-Climatiques/TransitioningToALowCarbonEconomy.pdf>

Public Safety Canada (PSC). 2019. The Canadian disaster database. The data were obtained online at:

<https://www.publicsafety.gc.ca/cnt/rsrscs/cndn-dsstr-dtbs/index-en.aspx>

Rampton, V.W., R.C. Gauthier, J. Thibault, and A.A. Seaman. 1984. Quaternary Geology of New Brunswick. *Geological Survey of Canada, Memoir*. 416.

Raymond, W.O. 1905. Glimpses of the Past, history of the River St. John, A.D. 1604-1784. Self-published, Saint John. 376p.

Roe, F.B. and N.G. Colby. 1875. Atlas of Saint John City and County New Brunswick. Roe & Colby, Saint John, New Brunswick. 91p.

Sadler, B. 1996. Environmental assessments in a changing world: evaluating practice to improve performance. Final report of the international study of the effectiveness of environmental assessment. Canadian Environmental Assessment Agency and International Association for Impact Assessment. Ottawa, Ontario. 263p. A copy of the document was obtained online at:

https://publications.gc.ca/collections/collection_2017/acee-ceaa/En106-37-1996-eng.pdf

Sawyer, C.N., P.L. McCarty and G.F. Parkin. 1994. *Chemistry for environmental engineering*, fourth edition. McGraw Hill: Toronto. 658p.

Species at Risk Act (SARA). 2021. A to Z species index. The list was obtained online at:

http://www.sararegistry.gc.ca/sar/index/default_e.cfm

Statistics Canada (StatsCan). 2021a. Gross domestic product (GDP) at basic prices, by industry, provinces and territories, growth rates (x 1,000,000). Data table 36-10-0402-02. The data were obtained online at:

<https://www150.statcan.gc.ca/t1/tbl1/en/tv.action?pid=3610040202>

Statistics Canada (StatsCan). 2021b. Labour force characteristics by province, monthly, seasonally adjusted. Data table 14-10-0287-03. The data were obtained online at:

<https://www150.statcan.gc.ca/t1/tbl1/en/tv.action?pid=1410028703>

Taylor, C. 2016. Our history, our stories: personal narratives and urban aboriginal history in New Brunswick. A copy of the document was obtained online at:

<https://uakn.org/wp-content/uploads/2016/02/Our-History-Our-Stories-NB-online.pdf>

United Nations Framework Convention on Climate Change (UNFCCC). 2021. The Paris Agreement. A copy of the information was obtained online at:

<https://unfccc.int/process-and-meetings/the-paris-agreement/the-paris-agreement>

United Nations Environment Programme (UNEP). 1973. Report of the United Nations Conference on the Human Environment in Stockholm, 5-16 June 1972. 81p. A copy of the document was obtained online at:

<https://undocs.org/en/A/CONF.48/14/Rev.1>

United States Environmental Protection Agency (USEPA). 1971. Noise from construction equipment and operations, building equipment, and home appliances. Report NTID 300.1. 337p. A copy of the document was obtained online at:

<https://nepis.epa.gov/Exe/ZyPDF.cgi/9101NN3I.PDF?Dockey=9101NN3I.PDF>

United States Environmental Protection Agency (USEPA). 2014. Technical development document for the final section of 316(b) existing facilities rule. EPA-821-R-14-002. 372p. A copy of the document was obtained online at:

https://www.epa.gov/sites/default/files/2015-04/documents/cooling-water_phase-4_tdd_2014.pdf

Urban Strategies Inc. 2011. PlanSJ, City of Saint John Municipal Plan. A copy of the document was obtained online at:

<http://www.saintjohn.ca/site/media/SaintJohn/Municipal%20Plan%20for%20web%202012-01-12.pdf>

Vasseur, L. and N. Catto. 2008. Atlantic Canada; *In* From Impacts to Adaption: Canada in a Changing Climate 2007, edited by D.S. Lemmen, F.J. Warren, J. Lacroix and E. Bush. Government of Canada, Ottawa, Ontario, p. 119-170. A copy of the document was obtained online at:

https://www.nrcan.gc.ca/sites/www.nrcan.gc.ca/files/earthsciences/pdf/assess/2007/pdf/full-complet_e.pdf

Warren, F. and N. Lulham. 2021. Canada in a changing climate: national issues report. Government of Canada, Ottawa. 734p. A copy of the document was obtained online at:

https://changingclimate.ca/site/assets/uploads/sites/3/2021/05/National-Issues-Report_Final_EN.pdf

Wood, C. 1995. Environmental impact assessment, a comparative review. Prentice Hall, Toronto. 337p.

World Resources Institute (WRI). 2021. CAIT climate data explorer. The data were obtained online at:

<http://cait.wri.org/>

Zwiers, F.W. and V.V. Kharn. 1998. Changes in the extremes of the climate simulated by CCC GCM2 under CO2 doubling. *Journal of Climate*, 11(9): 2200-2222.

<https://journals.ametsoc.org/doi/abs/10.1175/1520-0442%281998%29011%3C2200%3ACITEOT%3E2.0.CO%3B2>

10.0 GLOSSARY

ablation till: till that has been worn away from its parent layer by erosion or weathering.

activated sludge: a biological wastewater treatment process that uses aeration and a biological flocculant composed of bacteria, fungi, and protozoa to remove organic material from wastewaters. The term 'activated' refers to a significant portion of the settled biological flocculants, after treatment, being returned to the beginning of the treatment process to "activate" it, thereby beginning the process anew.

aeration basin: a holding and / or treatment pond equipped with artificial aeration to promote the biochemical oxidation of wastewaters.

airshed: a geographical area that shares the same air mass due to topography, meteorology, and / or climate and as a result, it behaves in a coherent way with respect to the dispersion of emissions.

ambient: the surrounding area or environment.

anadromous: fish that hatch and rear in freshwater, migrate to the ocean to grow and mature, and then migrate back to freshwater to spawn and reproduce.

anguilliform: the type of swimming mode for fish that swim like an eel and move through the water by undulating most or all of their body.

anthropogenic: caused by human activity.

Approval To Construct (ATC): Part I of the Air Quality Regulation [97-133] (*i.e.*, Sections 3 through 12) of the New Brunswick *Clean Air Act* and the Water Quality Regulation [82-126] of the New Brunswick *Clean Environment Act* [R.S.N.B. 1973, c. C-6] requires owners and / or operators of a facility that releases a contaminant to the environment to apply for and obtain approval for the construction of the source.

Approval To Operate (ATO): Part I of the Air Quality Regulation [97-133] (*i.e.*, Sections 3 through 12) of the New Brunswick *Clean Air Act* and the Water Quality Regulation [82-126] of the New Brunswick *Clean Environment Act* [R.S.N.B. 1973, c. C-6] requires owners and / or operators of a facility that releases a contaminant to the environment to apply for and obtain approval for the operation of the source.

aquifer: a saturated permeable geologic unit that can transmit significant quantities of water under ordinary hydraulic conditions.

archaeological and cultural features: all evidence of human occupation that comes out of the ground or underwater or on the ground, including shell middens, fishing stations, large First Nation villages, sugar-bush camps, shipbuilding yards, trading posts, shipwrecks, cemeteries, military forts, and a variety of other locations where humans, both long ago and more recently.

artifact: any ancient object that has been formed or altered by the human hand. There are thousands of types of artifacts in New Brunswick that can vary from 10 000 year old First Nation spear points to 17th century iron door hinges.

avian: a bird.

avoidance: the measures taken by a proponent to prevent impacts of a project on the environment.

baseline: background or pre-activity data that can be used for comparison when conducting further analyses.

bedrock: solid rock encountered below the soil or any other unconsolidated cover that occurs on the Earth's surface.

benthic: of, or relating to, the bottom or floor of a water body.

Best Management Practices (BMPs): techniques used to guide design and construction of an Undertaking to minimize adverse environmental impacts.

bioaccumulation: the buildup of a toxic substance within an organism over time.

bioassay: an analytical method used to determine the concentration or potency of a substance by its effect on living animals or plants or on living cells or tissues.

Biochemical Oxygen Demand (BOD; BOD₅): a standard measure of wastewater strength that quantifies the amount of oxygen consumed in a stated period of time and at a specific temperature, usually 5 days at 20 °C.

biodiversity: the number and variety of organisms found within a specified geographic region.

biological environment: considers the flora and fauna components of the environment and their interaction.

biomagnification: the increasing accumulation of a toxic substance in increasingly higher trophic levels.

biomass: waste material from plants or animals that is not used for food or feed and instead can be used in various industrial processes, such as energy production or as raw materials for manufacturing chemicals.

brackish: water that is slightly salty as it is a mixture of river water and seawater in estuaries.

brownfield: abandoned or underused industrial and commercial sites that may be or perceived to be contaminated and / or need extensive redevelopment.

bylaw: a law made by municipal government.

carbon dioxide (CO₂): an atmospheric gas, composed of carbon and oxygen, that is a major component of the carbon cycle and the predominant gas contributing to the greenhouse effect and is therefore known as a contributor to climate change. It is produced through natural processes, but is also released through anthropogenic activities, such as the combustion of fossil fuels to produce electricity.

carbon dioxide equivalent (CO_{2eq}): is used to compare the emissions from various greenhouse gases on the basis of their global-warming potential by converting amounts of other gases to the equivalent amount of carbon dioxide with the same global-warming potential.

carbon monoxide (CO): a colourless, odourless, and highly toxic gas that is a byproduct of combustion.

Chart Datum: Chart Datum is a plane of vertical reference to which all charted depths and drying heights are related; it is chosen to show the least depth of water found in any place under "normal" meteorological conditions; it is a plane so low that the water level seldom falls below it; it varies from place to place with the range of tide.

check dam: a small earthen, rock, or log dam constructed in a gully or drainage ditch to decrease the flow velocity, minimize channel scour, and promote deposition of sediment.

Chemical Oxygen Demand (COD): a measurement of biodegradable and nonbiodegradable organic matter, widely used as a means of measuring the strength of domestic and industrial wastewaters.

circa (ca): makes reference to an approximate date when the actual date is unknown.

clarification: the removal of fibres and other easily settle-able solids prior by conventional gravity separation.

Clean Water Act: a provincial *Act* administered by the New Brunswick Department of the Environment, which deals with protecting the overall water environment for all New Brunswickers to enjoy.

Clean Environment Act: a provincial *Act* administered by the New Brunswick Department of the Environment, which deals with protecting the overall environment for all New Brunswickers to enjoy.

climate: a description of aggregate weather conditions or the sum of all statistical weather information that is used to describe a place or region.

combustion emissions: air pollutants released solely as a result of burning material.

Committee On the Status of Endangered Wildlife In Canada (COSEWIC): a committee of experts that assesses and designated which wild species are in some danger of disappearing from Canada.

compensation: the measures taken by a proponent to make up for adverse environmental impacts of a project that exist after mitigation measures have been implemented.

conglomerate: cemented, rounded fragments of water-worn rock or pebbles, bound by a siliceous (*i.e.*, containing abundant silica) or argillaceous (*i.e.*, clay-size particles) substance.

contamination: the presence of a substance of concern, or a condition, in concentrations above appropriate pre-established criteria in soil, sediment, surface water, groundwater, air, and / or structures.

contingency plan: a set of pre-determined actions to be taken in the event of an accident, malfunction, or unplanned event.

cultural resources: archaeological and historic resources that are eligible for or listed by the government including buildings, sites, districts, structures, or objects having historical, architectural, archaeological cultural, or scientific importance.

cumulative impact: the impact on the environment that results from the incremental impact of the action when added to other past, present, and reasonably foreseeable future actions.

dBA: a sound level in decibels, measured with a sound level meter having metering characteristics and frequency weighting specified in American National Standard Specifications for sound level meters (ANSI S1.4-1971). It is common to refer to numerical units of an A-weighted sound level as "dBA". It is a frequency dependent correction that is applied to a measured or calculated sound of moderate intensity to mimic the varying sensitivity of the ear to sound for different frequencies.

decibel (dB): the universal logarithmic unit of sound measurement used to quantify magnitudes of sound and vibration that is commonly measured using a metre that registers sound pressure and displays the level on a scale.

decommissioning stage: the stage of a project during which the proponent permanently ceases commercial production and commences removal from service of any components of the project, and that continues until the site is restored.

deleterious substance: a substance that is harmful or dangerous.

detailed engineering: the process of and result from refining and expanding the preliminary design of a system or component to the extent that the design is sufficiently complete to be implemented.

Distributed Control System (DCS): a dynamic computerized network designed to regulate and monitor a production process.

diurnal: occurring in a 24 hour period; daily.

do nothing alternative: assessing the impacts if the Undertaking is not to proceed (*a.k.a.*, the null alternative).

earthquake: is the sudden release of stored elastic energy caused by the sudden fracture and movement of rocks along a fault; some of the energy released is in the form of seismic waves that cause the ground to shake.

ebb tide: the tidal current is flowing seaward.

ecosystem: a functional unit consisting of all the living organisms (*i.e.*, plants, animals, and microbes) in a given area, and all the non-living physical and chemical factors of their environment that are linked together through nutrient cycling and energy flow.

effluent: as defined under the Pulp and Paper Effluent Regulations [SOR / 92-269] of the *Fisheries Act* [R.S.C., 1985, c.F-14], effluent includes waste water from a mill, other than waste water from the treatment of intake water, including process water, gas scrubbing water, boiler blow-down water, wash-down water, cooling water, leachate from any site at the mill where solid residues generated by any mill are treated or disposed of, and leachate from any site at the mill where wood chips or hog fuel are stored.

emission: a form of pollution discharged into a receiving body from smokestacks, pipes, vents, surface areas of commercial or industrial facilities, from motor vehicles, locomotives, aircrafts, *etc.*

endangered: a species that is facing imminent extirpation.

endocrine disruption: when chemicals interfere with endocrine systems and result in disruptions, such as cancerous tumors, birth defects, and other developmental disorders.

entrapment: occurs when a fish is drawn into a water intake and cannot escape.

environmental effects monitoring: cyclical monitoring and interpretation phases designed to assess and investigate the impacts on the same parameters and location so that a spatial characterization of potential effects and a record through time to assess changes in receiving environments can be obtained.

environmental impact: the difference in the condition of an environmental component under project-induced change versus what that condition might be in the absence of project-induced change.

Environmental Impact Assessment (EIA): a study undertaken to assess the effect on a specified environment of the introduction of any new factor that may upset the current ecological balance and includes the social and physical environment of the surrounding area.

Environmental Protection Plan (EPP): a description of what will be done to minimize the environmental effects pre-, during, and post-construction of the Undertaking. The plan also includes mitigation measures.

Environmentally Significant Area (ESA): spaces that are provided special protection because they represent a habitat that is integral to the overall ecological health of the region.

erosion: the wearing away of land surface by wind or water, which naturally occurs from weather or runoff but can be intensified by land-clearing practices related to farming, residential or industrial development, road building, timber cutting, *etc.*

Erosion and Sedimentation Control Plan: a site-specific document that identifies potential sources of stormwater pollution, describes practices to reduce pollutants in stormwater discharges from the site, and identifies procedures that personnel can use to mitigate stormwater pollution.

Escherichia coli (E. coli): coliform bacteria of fecal origin that are harmful to human health and are therefore used as an indicator organism in water analysis to indicate contamination of an intestinal origin.

evaporation: the process whereby water changes from the liquid to vapour state.

excavate: the process of making a hole in something or removing a part of something by scooping or digging it out.

extinct: the death of the last individual of a species; the species ceases to exist on Earth.

extirpated: local extinction; ceases to exist within a defined geographical area, though it still exists elsewhere.

extreme weather: is weather that lies outside a locale's normal range of weather intensity (*e.g.*, hurricanes, tornadoes, ice storms, *etc.*); it is infrequent or rare and has the potential to be very destructive.

far field plume: the far field is the region where the effluent plume mixing processes are dominated by ambient advective and dispersive processes (*i.e.*, driven by tides, river flow, and baroclinic effects) and background build-up or longer term accumulation of effluent that may extend several kilometres from an outfall.

fauna: the collective animal life occurring in an area or time period, especially the naturally occurring indigenous animal life.

Fisheries Act: a federal *Act* administered by the Department of Fisheries and Oceans with respect to fish and fisheries in Canadian Waters.

Fisheries Authorization: New Brunswick's fish-bearing streams are afforded protection under Section 35(2) of the *Fisheries Act* [R.S.C., 1985, c. F-14], which is administered through the Federal Department of Fisheries and Oceans. Whenever there is a chance that fish and fish habitat will be altered, disrupted, or destroyed by an Undertaking, an authorization is required.

flood tide: the tidal current is flowing inland.

floodplain: the part of the ground surface inundated with water on a recurring basis, usually associated with the one percent recurrence interval (100-year) flow.

flora: the collective plant life occurring in an area or time period, especially the naturally occurring indigenous plant life.

fossil fuels: a naturally occurring fuel, such as coal or gas, that formed in the geological past as a result of organic material being buried.

fugitive emissions: pollutants released to the atmosphere but not through stacks, vents, pipes, or any other confined air stream.

Fundy Coast Ecoregion: the southern area of New Brunswick along the Bay of Fundy that is characterized by a distinctive climate, reflected in recurring patterns of vegetation on comparable landforms and soils that are different from the six other New Brunswick Ecoregions.

geology: the science that studies Earth by looking at its composition and the processes past and present that shaped it, both on the surface and within.

geotechnical study: below-ground investigation by boring, sampling, and testing the soil strata to establish its compressibility, strength, and other characteristics likely to influence a construction project, and to prepare a subsurface profile and soil report.

glacial: pertaining to an interval of geologic time that was marked by an equatorward advance of ice during an ice age.

Global-warming potential: a relative measure of how much heat a greenhouse gas traps in the atmosphere; it compares the amount of heat trapped by a certain mass of the gas in question to the amount of heat trapped by a similar mass of carbon dioxide.

greenhouse gas: a gas (*e.g.*, carbon dioxide, methane, nitrous oxide, hydrofluorocarbons, perfluorocarbons, sulphur hexafluoride, nitrogen trifluoride, *etc.*) that contributes to the greenhouse effect by absorbing radiation.

GreenHouse Gas Reporting Program (GHGRP): a Canada-wide single reporting system that tracks direct emissions from industrial, government, commercial, and other facilities that meet or exceed the reporting threshold for 26 greenhouse gases and gas species that are subject to mandatory reporting.

greenfield: a previously undeveloped open space, such as agricultural fields or forests, that has not been used for commercial or industrial activities and is presumed to be free of contamination.

ground truth: the process of verifying the correctness of remote sensing information by use of ancillary information, such as field studies.

groundwater: subsurface water that occurs beneath the water table in soils and geologic formations that are fully saturated.

guideline: a recommended, non-mandatory, optional practice that is not legislated (*i.e.*, does not have the force of law), but is a statement of desired, good, or best practice. They are often departmental documents that are used to interpret legislation and / or regulation.

habitat fragmentation: a process whereby large tracts of the natural landscape are gradually developed and subdivided until only patches of the original habitat remain and those remaining patches are often too small and too far apart to support the survival and reproductive needs for many wildlife species during various stages of their lifecycle or in different times of the year.

hazardous materials: a solid, liquid, or gaseous material that, upon exposure, constitutes an identifiable risk to human health or the natural environment. Hazardous material criteria are established with regard to appropriate regulatory requirements.

heavy metals: dense metallic elements (those with a specific gravity of 5.0 or greater), such as cadmium, mercury, and lead, that cannot be metabolized by the body and, if accumulated, can cause toxic effects by interfering with various physiological functions.

hibernaculum: an over-wintering area used to hibernate and survive the winter; bats typically seek out caves to hibernate.

hog fuel: any type of wood byproduct or waste, other than chips, shavings, bark, or sawdust, that can be burned for fuel.

horizontal directional drilling: a construction technique whereby a tunnel is drilled under a waterway or other designated area and a pipeline or other utility is pulled through the drilled underground tunnel.

hydrocarbons: a broad family of organic compounds that are comprised predominantly of carbon and hydrogen in various combinations; crude oil, natural gas, petroleum products, *etc.* are all various forms of hydrocarbons.

hydrogeology: the scientific study of groundwater geology and the geological environments that control the occurrence, movement, production, and characteristics of groundwater.

hydrology: an earth science that encompasses the occurrence, distribution, movement, and properties of water.

impermeable: not allowing water to pass through.

impingement: occurs when an entrapped fish is held in contact with a water intake screen and is unable to free itself.

Important Bird Area (IBA): an area recognized as being globally important for the conservation of bird populations. There are about 10 000 sites globally.

infiltration: the movement of water from the land surface to the subsurface.

Kraft pulping: is a process for converting wood into wood pulp consisting almost entirely of cellulose fibers. The process involves treating wood chips with a mixture of sodium hydroxide and sodium sulfate (*i.e.*, white liquor) to break the bonds that link lignin to the cellulose.

land parcel: an area of land for which rights or ownership can be purchased.

land use: the way that land is developed and used in terms of the kinds of activities allowed (*e.g.*, agriculture, residences, industries, *etc.*).

long-term impacts: those that are experienced for a prolonged period, such as during the entire duration (*i.e.*, operation) of the Undertaking.

Magnitude (M): is a measure of the amount of energy released during an earthquake; all magnitude scales are calibrated to the original scale defined by Richter.

mainshock: is the largest earthquake in a cluster of earthquakes; mainshocks are sometimes preceded by foreshocks and generally followed by aftershocks.

may: the term used to express an option or that which is permissible within the limits of the requirement.

microbiology: the science and study of microorganisms (too small for the naked eye to detect), including protozoans, algae, fungi, bacteria, and viruses, and how they affect humans.

micro-climate: an area influenced by natural or human-made features that alter the climatic conditions from the general regional climate.

migratory birds: land birds that migrate very long distances to breed or escape temperatures outside their normal optimum temperature range.

mill: a factory or complex of factories that is designed or used to produce pulp and paper products.

mitigation: the measures taken by a proponent to reduce adverse impacts of a project on the environment.

morainal sediments: glacial drift materials deposited mainly by direct glacial action and possessing initial constructional form independent of the material beneath it.

Moving Bed Biofilm Reactor (MBBR): is a biological wastewater treatment process that uses engineered polyethylene carriers (media) to create a large protected surface on which biofilm can attach. The media is mixed in the reactor, and the large surface area provides more treatment capacity in a smaller volume compared to conventional treatment methods.

***n*:** see sample size.

National Pollutant Release Inventory (NPRI): a legislated and publicly-accessible Canada-wide database that tracks information about onsite releases, offsite transfers for recycling and disposal, and pollution prevention implemented by industrial, government, commercial, and other facilities.

Navigation Protection Permit: any works that may affect navigation on navigable waters in Canada requires approval under the *Canadian Navigable Waters Act* [R.S.C., 1985, c. N-22].

near bed effluent plume: the effluent plume near the bed of the waterbody.

nitrogen oxides (NO_x): a generic term for the most relevant oxides of nitrogen responsible for air pollution, such as nitric oxide and nitrogen dioxide. These gases contribute to the formation of smog and acid rain, as well as affecting tropospheric ozone.

noise: unwanted sound.

no-net-loss: for this EIA it refers to wetlands and acknowledges that wetland alterations will occur, some naturally and some through necessary and beneficial (socially and economically) human activities, but that those losses must be avoided, minimized, and compensated for.

Navigational Warnings (NAVWARNs): notices concerning navigational aid changes or defects, fishing zones, military exercises, dredging, or other marine hazards and contains information for all boaters and is intended to inform the marine community of hazards, current activities, and other pertinent information.

null alternative: assessing the impacts if the Undertaking is not to proceed (a.k.a. the do nothing alternative).

olfactory: pertaining to the sense of smell.

operation and maintenance stage: the stage of the project during which the commercial production takes place, including periods during which commercial production may temporarily cease, and that continues until the start of decommissioning.

outcrop: exposed stratum or body of ore at the surface of the Earth.

outfall: the place where a sewer, drain, or stream discharges into adjacent water.

Parcel / Property IDentification (PID) number: a unique number given to a land parcel for tracking information, such as deed holders, size, environmental issues, *etc.*

Parcel Information: Service New Brunswick (SNB) maintains a network of registries across the province where legal plans and documents related to the ownership of real property can be registered and made available for public scrutiny. The records in the Registries provide land ownership information dating back to the issuance of the original crown grants. Instruments registered or filed in the registry include deeds, mortgages, wills, subdivision plans, *etc.*

permanent impacts: those that cause irreversible change to the environment.

Personal Protective Equipment (PPE): safety clothing, helmets, goggles, earplugs, steel-toe boots, or other garments or equipment designed to protect the wearer from body injury or infection.

petroleum hydrocarbons: a family of naturally occurring liquid organic compounds,

pH: a measure of the acidity or alkalinity of a solution; a measure of the hydrogen ion concentration on a scale of 0 to 14 where a value of 7 is neutral, values below 7 indicate an increasing level of acidity, and values above 7 indicate an increasing level of alkalinity.

physiochemical environment: considers the chemical and physical components of the environment and their interaction.

physiographic region: an area having a pattern of relief features or landforms that differ significantly from that of adjacent areas.

policy: a governing principle, which is not resolved on the basis of facts and logic only, that embraces general goals and mandates or constrains actions.

precipitation: any kind of water that falls from the sky (*i.e.*, snow, rain, freezing rain, sleet, hail, virga, *etc.*) as part of the weather at a specified place within a specified period of time.

pre-cast: a concrete unit, structure, or member that is cast and cured in an area other than its final position or place.

primary treatment: the first stage of wastewater treatment, which typically involves the removal of floating debris and solids by screening and / or settling processes.

posted speed: the speed that is established for a roadway and that motorists can legally travel.

potable: safe for human consumption, such that it can be used in the preparation of food and beverages or for the cleaning of utensils and dishes used in the preparation of food and beverages.

potable groundwater well: a hole bored, drilled, or otherwise constructed in the ground to tap an aquifer for obtaining a source of drinking water.

raw industrial freshwater: water that has not been treated.

receptor: a sensitive component of the ecosystem that reacts to or is influenced by environmental stressors.

refuse: all discarded solid material waste that has no end use.

Regulation: a form of law, which defines the application and enforcement of legislation. They are made under the authority of an Act.

Regulator / Regulatory Authority: the agency / department that oversees and applies the Act and regulations governing the environment; for this EIA the Regulator includes the City of Saint John, the New Brunswick Department of the Environment, the New Brunswick Department of Natural Resources, the Department of Fisheries and Oceans, and Environment Canada.

regulatory limit: the maximum concentration of a contaminant that can be within a specific sample without a cause for concern.

residual impact: the impact that remains after mitigation measures have been applied to reduce the activity's impact.

reverse osmosis filtration: a method of separating water from dissolved salts by passing feedwater through a semipermeable membrane at a pressure greater than the osmotic pressure caused by the dissolved salts.

runoff: the flow of water that occurs when excess stormwater, meltwater, or other sources flows over the Earth's surface.

Saint John Census Metropolitan Area: an area used for collecting census data, which is comprised of the city of Saint John, the suburbs of Rothesay, Quispamsis, Grand Bay-Westfield, and rural areas of Hampton and St. Martins.

Saint John Station A: the weather station at the Saint John airport where various weather parameters are monitored and recorded for determining the climate of the area.

salmonids: members of the fish family Salmonidae, which includes salmon, trout, and chars.

sample size (n): the number of samples in the data set.

sanitary waste: liquid or solid waste originating solely from humans and human activities, such as wastes collected from toilets, showers, wash basins, sinks used for cleaning domestic areas, sinks used for food preparation, clothes washing operations, and sinks or washing machines where food and beverage serving dishes, glasses, and utensils are cleaned, but does not include hazardous or radioactive materials.

sedimentation: the process of depositing soil particles, clay, sands, or other sediments that were picked up by wind or flowing water.

sedimentation basin: a depression that floodwater or stormwater is directed to in order to remove suspended matter by settling; flow into the basin causes a reduction in velocity, which allows suspended matter to settle.

seismic zone: an area of the Earth's crust in which movements, sometimes associated with volcanism, occur.

seismicity: the occurrence of earthquakes in space and time.

short-term impacts: those that are only experienced for a brief period or during a portion of the Undertaking (*i.e.*, during the pre-construction, construction, or commissioning).

should: the term used to express a recommendation or that which is advised but not required.

silt fence: a temporary barrier fence constructed of wood or steel supports and either natural (*e.g.*, burlap) or synthetic fabric stretched across areas of non-concentrated flow during construction activities to trap and retain onsite sediment runoff due to precipitation.

site: a subset or combination of properties, as defined by the scope of work.

site leveling: the process of modifying the topography along the Undertaking footprint to accommodate it.

socioeconomic environment: considers the social and economic components of the environment and their interaction.

soil: unconsolidated mineral and organic material on the immediate surface of the earth that serves as a natural medium for the growth of plants.

solid waste: non-liquid or gaseous waste that can be accepted for disposal in a landfill or incinerator and includes food waste, paper and cardboard, yard waste, metals, plastics, *etc.*, but does not typically include industrial waste, medical waste, or hazardous waste.

sound: a combination of pressure waves of different frequencies and amplitudes travelling through a medium, such as air or water.

sound frequency: the number of cycles per second that a sound wave oscillates, which is usually expressed in Hertz (Hz).

sound intensity: the flow of sound energy through a unit area in a unit time, which is normally expressed in decibels (dB).

spatial: of or relating to space.

special concern: a species that may become threatened or endangered because of a combination of biological characteristics and identified threats.

Species At Risk Act (SARA): a federal Act administered by Environment Canada with the goal of protecting Canada's wildlife.

storm surge: a rise above normal water level on the open coast due only to the action of wind stress on the water surface; storm surge resulting from a hurricane or other intense storm also includes the rise in level due to atmospheric pressure reduction as well as that due to wind stress.

subcarangiform: the type of swimming mode for fish that swim like salmonids and move through the water by undulating the posterior third to half of their body.

sulphur oxides (SO_x): a generic term for the most relevant oxides of sulphur responsible for air pollution, such as sulphur dioxide, sulphur trioxide, *etc.* These gases, especially sulphur dioxide, are emitted by the burning of fossil fuels contribute to the formation of smog and acid rain, as well as affecting tropospheric ozone.

surface effluent plume: the effluent plume near the surface of the waterbody.

surface water: all water that flows in watercourses and wetlands or is held in reservoirs above the Earth's surface.

surficial sediments: unconsolidated alluvial (*i.e.*, formed by running water), residual, or glacial deposits overlying bedrock or occurring on or near the surface of the earth.

sustainable: systems that focus on lasting longer and have less impact on the environment, particularly in relation to major global concerns, such as oil depletion and climate change. Sustainable products can be used indefinitely without the possibility of depletion, thus complementing ecological systems and ensuring intergenerational equity.

Technical Review Committee (TRC): with respect to an EIA review, the TRC is a group of professionals that are brought together to advise the regulator on matters related to their area of expertise.

temporal: of or relating to time.

terrestrial: relating to or inhabiting the land (*e.g.*, terrestrial plants live on the land as opposed to in the water).

The Paris Agreement: an agreement within the United Nations Framework Convention on Climate Change dealing with greenhouse gas emissions mitigation, adaptation, and finance, starting in the year 2020.

threatened: a species that is likely to become endangered if nothing is done to the factors leading to its extirpation or extinction.

till: unsorted and unstratified drift consisting of a heterogeneous (*i.e.*, non-uniform) mixture of clay, sand, gravel, and boulders that is deposited by and underneath a glacier.

topography: the physical features of a geographical area including relative elevations and the position of natural and anthropogenic features.

total coliforms: a family of rod-shaped mostly harmless bacteria that reside in the intestines of humans and other warm-blooded animals, which are shed in fecal material; their presence in potable water suggests that the water has received contamination of an intestinal origin.

total emissions: the sum total mass of each gas or gas species multiplied by their respective global warming potential.

Total Suspended Solids (TSS): a measure of the amount of particles that are dispersed in a liquid due to turbulent mixing, which can create turbid and cloudy conditions; includes a wide variety of materials, such as silt, organics, industrial wastes, and sewage.

trace metals: a group of metal elements, present in very low concentrations, that were analyzed within all the potable water samples collected for this baseline study and comprising 31 species.

Transitioning to a Low-Carbon Economy: a bold vision developed for New Brunswick to intensify efforts to combat climate change.

treated effluent: for the purposes of this project, waste water from a mill (other than waste water from the treatment of intake water, including process water, gas scrubbing water, boiler blow-down water, wash-down water, cooling water, leachate from any site at the mill where solid residues generated by any mill are treated or disposed of, and leachate from any site at the mill where wood chips or hog fuel are stored) that has been through the secondary clarifiers of the ETF following biological treatment.

turbidity: a qualitative measurement of water clarity resulting from suspended matter that scatters or otherwise interferes with the passage of light through the water.

Universal Transverse Mercator (UTM) coordinate system: a mapping grid developed by the National Imagery and Mapping Agency (USA). The globe is divided into numbered zones, and within each zone northing and easting values are used to locate any point on the Earth's surface.

Valued Environmental Component (VEC): components of the human and physical environment that are considered important and therefore require evaluation through an environmental impact assessment.

varmint: small nuisance animals, such as raccoons, foxes, and coyotes.

Volatile Organic Compounds (VOCs): compounds, such as gasoline, that contain carbon and readily evaporate into the air; they contribute to the formation of smog and may be toxic.

wastewater: liquid or waterborne wastes polluted or fouled from household, commercial, or industrial applications along with any surface water, stormwater, or groundwater infiltration.

watershed: an area of land that drains to a single outlet and is separated from other watersheds by a divide.

Watercourse and Wetland Alteration (WAWA) permit: in New Brunswick, watercourses and wetlands are afforded protection under the *Clean Water Act* (Regulation 90-80) with respect to a temporary or permanent change made at, near, or to a watercourse or wetland or to the water flow in a watercourse or wetland. The permits are administered by the New Brunswick Department of the Environment.

watercourse: the full width and length, including the bed, banks, sides and shoreline, or any part of a river, creek, stream, spring, brook, lake, pond, reservoir, canal, ditch, or other natural or artificial channel open to the atmosphere, the primary function of which is the conveyance or containment of water whether the flow be continuous or not.

weather: the state of the atmosphere at any given time.

wellfield: an area containing one or more potable groundwater wells that is used to provide water.

wetland: land that either periodically or permanently, has a water table at, near, or above the land's surface or that is saturated with water and sustains aquatic processes as indicated by the presence of hydric soils, hydrophytic vegetation, and biological activities adapted to wet conditions.

11.0 REPORT DISCLAIMERS AND DISCLOSURES

The sole purpose of this report and the associated services performed by Fundy Engineering & Consulting Ltd. is to complete an Environmental Impact Assessment document for the environmental treatment facility and water use reduction project at the Irving Pulp & Paper, Limited Reversing Falls Mill in Saint John, New Brunswick. The scope of services was defined by the New Brunswick Department of the Environment and Local Government's guidelines to Environmental Impact Assessment in New Brunswick [NBDELG, 2012] and the NBDELG [2004] Sector Guidelines for Wastewater Treatment Projects.

This report was prepared on behalf of and for the exclusive use of the Client. The report expresses the professional opinion of Fundy Engineering experts and is based on their technical / scientific knowledge. Fundy Engineering & Consulting Ltd. accepts no liability or responsibility whatsoever for or in respect of any use of or reliance upon this report or data by any third-party. Fundy Engineering makes no guarantee that the Client will be successful in the regulatory approval.

Serving Our Clients' Needs First

Fundy Engineering is proud to be one of the largest employee-owned, full-service multi-disciplinary engineering-consulting companies headquartered in New Brunswick and serving Atlantic Canada and New England

Top-Quality Engineering-Consulting Solutions

Bio-Resources | Building Systems | Environmental | Geotechnical & Surveying | Project Management

**FUNDY
ENGINEERING
& CONSULTING**

 **877.635.1566**

 **fundy@fundyeng.com**

 **www.fundyeng.com**

FUNDY Engineering

Thank you for choosing our team for your engineering and consulting needs. We encourage you to visit our website and share your needs and concerns so that we can continue to provide you with top-quality technically sound solutions.

SAINT JOHN OFFICE

27 Wellington Row
PO Box 6626
Saint John, NB E2L 3H4

506.635.1566

***Serving the Atlantic Region from
Saint John and Clyde River***

CLYDE RIVER OFFICE

945AA Upper Meadowbank Road
Clyde River, PE
C0A 1H1

902.675.4885