

## Appendix B

## PROJECT: C15.23 OBH GENOMICS UNIT

VERSION: 1

DESIGN SUMMARY FOR:

FACILITY TO PRODUCE

224 INDIVIDUAL FAMILIES

9 MULTIPLIER GROUPS

3 CHALLENGE GROUPS

PREPARED FOR:



KELLY COVE SALMON  
A DIVISION OF COOKE AQUACULTURE  
669 MAIN STREET  
BLACKS HARBOUR  
NEW BRUNSWICK, CANADA  
E5H 1K1

PREPARED BY:



134 CARLETON STREET  
SAINT ANDREWS  
NEW BRUNSWICK, CANADA  
E5B 1N9

31/07/2017

## TABLE OF CONTENTS

<b>1.0 PROPONENT DESCRIPTION .....</b>	<b>3</b>
<b>2.0 DESCRIPTION OF THE UNDERTAKING .....</b>	<b>4</b>
<b>2.1 NAME OF UNDERTAKING .....</b>	<b>4</b>
<b>2.2 LOCATION .....</b>	<b>4</b>
<b>3.0 PROJECT OVERVIEW .....</b>	<b>4</b>
<b>4.0 SITING CONSIDERATIONS .....</b>	<b>7</b>
<b>5.0 PHYSICAL COMPONENTS AND DIMENSIONS OF THE PROJECT .....</b>	<b>8</b>
<b>5.1 EGG INCUBATION .....</b>	<b>8</b>
<b>5.2 FAMILY, MULTIPLIER &amp; SWEDE TANKS .....</b>	<b>8</b>
<b>5.3 CRYOPRESERVATION LABORATORY .....</b>	<b>9</b>
<b>5.4 DESIGN CRITERIA .....</b>	<b>10</b>
<b>6.0 APPENDIX A - DRAWINGS .....</b>	<b>12</b>
<b>2 LOCATION MAP .....</b>	<b>13</b>
<b>2-3712 – SUBDIVISION PLAN .....</b>	<b>14</b>
<b>L-1A PLAN – PROJECT .....</b>	<b>15</b>
<b>L-1B PLAN – EFFLUENT CONNECTION .....</b>	<b>16</b>
<b>L-2 BRIDGE DETAILS .....</b>	<b>17</b>
<b>D-2 PLAN – BUILDING .....</b>	<b>18</b>
<b>R-1 NORTH-EAST ISOMETRIC .....</b>	<b>19</b>
<b>R-2 SOUTH-WEST ISOMETRIC .....</b>	<b>20</b>

## 1.0 PROPONENT DESCRIPTION

Cooke Aquaculture Inc. (Cooke) is an integrated aquaculture company based in Atlantic Canada that rears, processes, and sells Atlantic salmon, sea bass, and sea bream through its wholly-owned subsidiaries. Through its farming division, Kelly Cove Salmon (KCS), it operates a salmon hatchery in the community of Oak Haven, Charlotte County, New Brunswick. The facility consists of a hatchery, enclosed tank fields and wastewater treatment system, and includes a broodstock rearing operation for gamete production and incubation room for housing salmon eggs. Cooke purchased the Oak Bay facility in 1989 under the name Kelly Cove Salmon and it has been under their operation since.

### 1.2 Proponent Information

Table 1.1 highlights the contact information for the Proponent and their environmental consultant.

**Table 1.1: Proponent and Consultant Information**

<b><u>Proponent</u></b>	
<b>Name of Proponent</b>	Kelly Cove Salmon
<b>Postal Address</b>	669 Main Street Blacks Harbour, NB E5H 1K1
<b>Telephone:</b>	(506) 466-6634
<b><u>Proponent Contact</u></b>	
<b>Name</b>	Mitchell Dickie
<b>Official Title</b>	Project Manager for Freshwater Systems
<b>Address</b>	As Above
<b>Phone</b>	(506)755-5282
<b>Email</b>	mitchell.dickie@cookeaqua.com
<b>Website</b>	<a href="http://www.cookeaqua.com">http://www.cookeaqua.com</a>
<b><u>Consultant Contact</u></b>	
<b>Company</b>	Sorensen Engineering Ltd.
<b>Name</b>	Marc Sorensen
<b>Official Title</b>	President
<b>Address</b>	134 Carleton St. St. Andrews, NB E5B 1N9
<b>Telephone</b>	(902) 835-5560
<b>Fax</b>	(902) 835-5574
<b>Email</b>	marc@soreng.ca

## 2.0 Description of the Undertaking

### 2.1 Name of Undertaking

The undertaking is being referred to as the Family Genomics Breeding Station and Gene Bank Library, and would be referred to in this document as “the Project”.

### 2.2 Location

The Project site is located at the existing Oak Bay Hatchery, 93 Oak Haven Road, Oak Haven, Charlotte County, approximately 6.5 km northeast of the town of Saint Stephen, NB (Drawing 1, Appendix A). The Project site is located within Parcel Identifiers (PIDs) 01265925, 01270503, 15155419, 15202062 (the Project Property) (Drawing 2-3712 – SUBDIVISION PLAN, Appendix A). The Project site is bordered by Oak Haven Road to the north and west, forested land to the south, and Oak Bay to the east. Access to the site is provided via two gated entrances along Oak Haven Road.

Project location details are provided in Table 2.1.

**Table 2.1: Property Location Information**

<b>Site Name</b>	Oak Bay Salmon Hatchery
<b>Civic Address</b>	93 Oak Haven Road
<b>PID(s)</b>	01265925, 01270503, 15155419, 15202062
<b>Community</b>	Oak Haven, NB
<b>County</b>	Charlotte County
<b>1:50 000 Topographic Map #</b>	21G Edition 3 UTM Zone 19
<b>Grid Reference</b>	45°12'49.30"N, 67°11'51.43"W 5008269.75 m N, 641525.99 m E (Zone 19T)

## 3.0 Project Overview

The Family Genomics Breeding Station and Gene Bank Library is the foundation piece in Cooke Aquaculture’s \$4.9M investment in advanced broodstock genomics and next generation sequencing to maximize the inherent genetic potential of the company’s farmed stocks. Because commercial aquaculture companies operating in Atlantic Canada are restricted, by legislation, to the use of the Saint John River Aquaculture Strain (SJR) of the North American subspecies of Atlantic salmon, the company must make such an investment to continue to compete successfully with larger global producers who have access to multiple strains of highly selected

European Atlantic salmon through worldwide egg supply provided by specialized breeding companies. Such Atlantic strains have been domesticated and selected for over 40 years. They are often better adapted to commercial growing conditions than the less genetically advanced SJR strain; thus placing Atlantic Canada's farmers at a competitive disadvantage in terms of achieving genetic gains for desirable traits such as improved growth rate, resistance to sea lice and disease, or enhanced carcass traits (e.g. increased yield, improved colour, etc.). Furthermore, many international competitors are now incorporating advanced genomics tools into their breeding programs to improve selection accuracy and increase genetic gains per generation. Accordingly, Cooke Aquaculture must also move in this direction to remain competitive.

The design of the new state-of-the art facility (Figure 1) will feature the latest generation of water management systems and fish rearing technology and equipment, as well as modern innovative energy saving approaches to maintain optimal rearing temperatures. The facility provides for tanks to accommodate 224 genetically distinct families from which elite broodstock can be developed on a commercial scale

The broad objective of the project is to assist Cooke Aquaculture in gaining the broodstock genomic information needed to continue competing successfully against large multinational companies.

The eggs required for the company's genomics program would be taken from the existing egg production on site, offsetting current fry production. The Project would allow for the creation and tracking of multiplier groups, as well as for groups to be sent to specialized, accredited laboratories for disease challenges, and to salt water farms for performance evaluation. No genetically modified species would be utilized since the company uses only the SJR strain.

The Project would result in no increases to the site's total number of fish, annual bio-mass, or annual feed consumption.

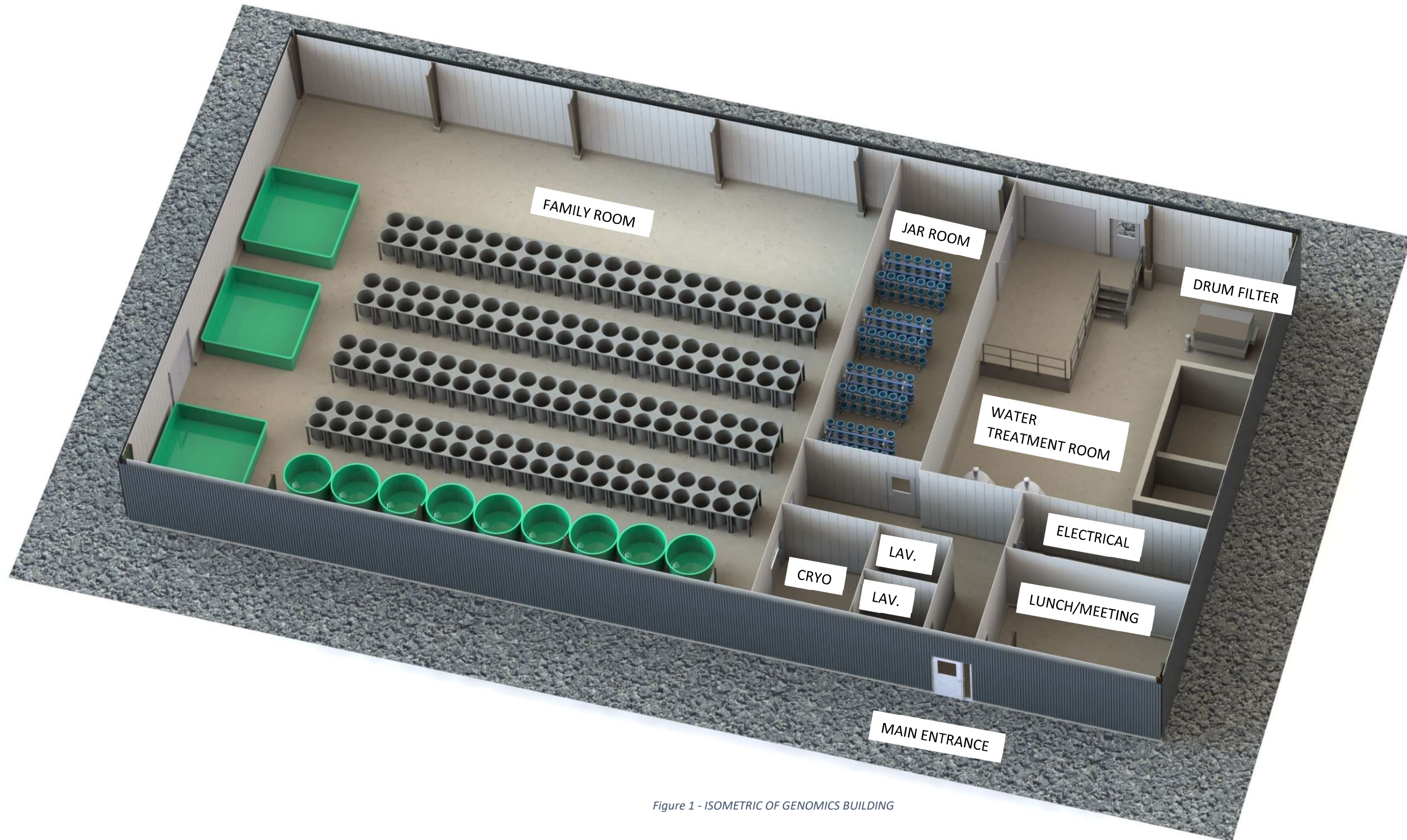

Figure 1 - ISOMETRIC OF GENOMICS BUILDING

The project would require no additional water withdrawal, nor would any new wells be required. Water would be pumped to the facility from the existing Tech Room, identified on drawing L-1A.

Effluent from the facility would be divided into 2 streams, discharge and waste. Each effluent stream would be piped from the project location to the existing effluent treatment system on site, located on drawing L-1B. Effluent quality from the site would be marginally improved.

Oxygen gas would be piped to the facility from the Tech Room, identified on drawing L-1A.

There would be a new electrical entrance to supply the facility. Emergency back-up power would be supplied by generators currently located in the Tech Room, identified on drawing L-1A.

No modifications to the site's effluent treatment building are required.

## 4.0 Siting Considerations

The proposed location for the Project was chosen in part because of the existing infrastructure and personnel existing at the site. These existing resources minimize the construction and operating costs of the Project.

The water source on site has been in use more than 20 years and has been found reliable in both flow and quality.

A significant portion of the material to be excavated in the preparation of the site is gravel. The value of the material was considered in the purchase price of the property from Southwest Concrete, who will recover the material.

During construction, there would be temporary access from the Southwest Concrete pit adjacent the property on PID 01267244.

Following completion of the Project the temporary access route would be restricted and access to the facility would be across a bridge spanning Hitchens Creek. This would be the only access and would ensure a high level of bio-security. In 2016 a permit to build the bridge was obtained from the Province of New Brunswick (40811'16), but construction was not completed. A drawing for the bridge, L-2 it is attached is Appendix B.

The Project would be located within an area identified as Zone C in the Coastal Areas Protection Policy for New Brunswick. The installation of effluent piping would require work within a Zone B, but would remain 25m from Zone A or the Higher High Water Large Tide (HHWLT).



The Province will be consulted as to if a watercourse alteration permit is required for the installation of piping from the Project to the existing Effluent Treatment Building and Tech Room.

The Department of Fisheries and Oceans has previously described the section of Hitchens Creek, from the proposed bridge location to the shore, as 'Not Fish Habitat'.

## 5.0 Physical Components and Dimensions of the Project

The new facility would be an insulated steel building measuring approximately 34.2m [112'-5"] by 24.4m [80'-0"], with concrete foundation and floor.

### 5.1 Egg Incubation

The egg incubation section of the facility would include 6 racks with 42 (5L) jars each, totaling 252 jars.

3 sets of 2 racks would each be plumbed to a dedicated temperature control system, which would use air-sourced heat pumps. This would make it possible to operate pairs of racks down to 2°C, while operating another pair at independent temperatures.

Since there is no feeding in the jars, minimal water treatment is required. However, relatively high flows are required to ensure the eggs are properly suspended. Therefore, the water would be disinfected with UV-treatment and recirculated. (Currently, there is no temperature control and water is not recirculated.)

One batch of eggs would pass through the egg incubation systems per year. As eggs are moved out to the recirculation system, the water demand of the incubation systems will decrease. The egg incubation and recirculation system would never be at peak water demand simultaneously.

### 5.2 Family, Multiplier & Swede Tanks

The 100 existing family tanks (130L) on site would be relocated to the new facility and 124 new family tanks (130L) would be added, totaling 224 tanks.

There would be 9 combi tanks (1,500L) for Multiplier Groups and 3 Swede-style tanks (9,000L) for growth performance trials.

The family tanks, combi tanks and Swede-style tanks would all operate on one recirculation system. All tanks would gravity flow to a common drum filter with 40µm filter panels, which would capture 90% of the solids. Filtered water would then pass through a bio-filter, for ammonia conversion to nitrite, then nitrate using bacteria. The water would then pass through a fine solid capture device and then gas balancing, which would

remove excess carbon dioxide and transfer the necessary oxygen, before gravity flowing back to the tanks. There would also be UV treatment installed on the recirculation system.

pH would be monitored with a pH probe located in the pump reservoir and adjusted with the addition of sodium hydroxide (NaOH) via a peristaltic dose pump. This is controlled automatically within set parameters which are normally (7.3 +/- 0.1). CO<sub>2</sub> is partially controlled through the pH of the system.

The individual family tank unit would be equipped with a robot feeding system. This unit is already in use in the existing family room at the site and would be moved to the new facility and recommissioned when the facility is ready. The system is capable of individually feeding 224 tanks at user defined time intervals and percentage feed per body weight per day. The feeder is controlled by a designated computer system and self-charges its built-in batteries after each feeding loop. The computer program adjusts to the fry (fish) size automatically based on amounts of feed being fed and can be corrected manually by the user if required.

Since the incubation jars and recirculation system will not operate at full capacity simultaneously, the peak water consumption of the facility would remain less than 50m<sup>3</sup>/day.

### 5.3 Cryopreservation Laboratory

The Cryo Lab would be initially fitted with a 47 L storage Dewar flask capable of holding milt samples from 100-150 elite males. There is space to expand to more flasks in future if required for longer term storage. The lab would have a stainless steel work bench area for handling the cold milt samples and have space for manipulating and preparing the samples. There would be a microscope and a milt concentration spectrophotometer in this area as well. The room would be equipped with an oxygen alarm sensor, since liquid nitrogen displaces oxygen, as a safety feature to warn staff if oxygen levels are dropping. An extraction fan that vents air to the outside would be turned on when working with the liquid nitrogen so that the bulk of liquid nitrogen vapor can be eliminated effectively. Safety gloves, aprons, and mask would be used by staff when placing or taking samples to/from the Dewar flask or filling it with liquid nitrogen from the supply tank located outside. The storage Dewar would be fitted with a level indicator and alarm so that adequate liquid nitrogen levels can be maintained. Bulk liquid nitrogen tanks for filling the storage Dewar would be rented from Praxair in Saint John.

## Dimensioning Criteria - Recirculation

Parameter	Unit	Family Tanks	Multiplier Tanks	Challenge Tanks	Grand Total
Temperature	°C	15	18	18	
Salinity	‰	5	5	5	
Total Tank Volume	m <sup>3</sup>	29.6	13.5	27	70.1
Fish Quantity @ Peak Bio-mass	pcs	49,300	27,000	41,000	117,300
Fish Size @ Peak Bio-mass	g	25.0	25.0	25.0	
Bio-mass @ Peak	kg	1,232	675	1,020	2,927
Feeding @ Peak	%BW/day	2.5%	2.5%	2.5%	
	kg/day	31	17	26	73
Oxygen Demand @ Peak	kg/day	12	7	10	29
CO2 @ Peak	mg/L	22	22	22	
TAN @ PEAK	mg/L	1.7	1.7	1.7	1.7
Make-up (New Water)	L/kgFEED	350	350	350	
	m <sup>3</sup> /hr	0.45	0.25	0.37	1.07
Recirculating Flow	m <sup>3</sup> /hr	59	27	54	140
<b>Tanks</b>					
Fish Quantity @ Peak		220	3,000	13,600	
Bio-mass @ Peak	kg	5.5	75.0	340.0	
Feeding @ Peak	kg/day	0.14	1.88	8.50	
Quantity	pc.	224	9	3	
Volume	m <sup>3</sup>	0.132	1.5	9.0	
Density	kg/m <sup>3</sup>	42	50	38	
Water Exchange @ Peak	Per hr	2.0	2.0	2.0	
Retention time	min.	30	30	30	
Water Flow per Tank	m <sup>3</sup> /hr	0.264	3.0	18.0	
<b>LHO</b>					
Water Flow	m <sup>3</sup> /hr				140
Oxygen Inlet	mg/L				10.0
Oxygen Outlet	mg/L				19.0
ΔOxygen	mg/L				9.0
Oxygen Supply (LHO)	kg/day	-	-	-	30.3

<b>Bio-Filter</b>		
Loading	kg/m <sup>3</sup> <sub>media</sub>	8.00
Media Volume	m <sup>3</sup> <sub>media</sub>	10
Fill Ratio	%	50%
Chamber Volume	m <sup>3</sup>	20
Chamber Width	m	2.74
Velocity	m/min	0.41
Chamber Depth	m	2.10
Chamber Length	m	3.5
Blower Power	W/m <sup>3</sup>	70
	kW	1.4
Ammonia Production	kg/day	3.35

## Dimensioning Criteria - Incubation Jars

Parameter	Unit	Rack Pair	Rack Pair	Rack Pair	Grand Total
		1	2	3	
Temperature	°C	2-8	2-8	2-8	
Salinity	‰	0	0	0	
Total Jar Volume	L	420	420	420	1260
Total Jar Qty	ea.	84	84	84	252
Rack Qty	ea.	2	2	2	6
Rack Jar Qty	Jars/Rack	42	42	42	
Jar Vol.	L	5	5	5	
Jar Flow	LPM/Jar	1.5	1.5	1.5	
Total Recirculating Flow	LPM	126	126	126	378
	m <sup>3</sup> /hr	7.56	7.56	7.56	22.7
Make-up (New Water) Flow	LPM	10.08	10.08	10.08	30.2
	m <sup>3</sup> /hr	0.60	0.60	0.60	1.81
Make-up/Recirc	%	8%	8%	8%	
Jar Vol. / Make-up	hr	0.69	0.69	0.69	

## Appendix A - Drawings



**Notes:**

- Reference: New Brunswick Digital Topographic Mapping, GeoGratis Digital NTS Map 21G03.
- Projection: NAD83(CSRS), New Brunswick Stereographic

- Legend:**
- Oak Bay
  - Building
  - Major Roads and Highways
  - Public Roads
  - Limited Use Road
  - Railway
  - Trail / Access Road
  - Transmission Line
  - Watercourse
  - Building
  - Quarry
  - Sand
  - Provincial Park
  - Provincial Significant Wetland
  - General Wetland
  - Transformer Station
  - Water Bodies

**Location Map**



Date: April 2015	Project #: 15-5278
Scale: 1:25,000	Drawing #:  <b>2</b>
Drawn By: H. Serhan	
Checked By: H. Mosher	

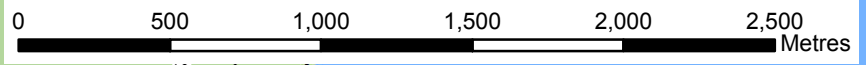



NOTES:  
 1.1 PIPING TO BE QUOTED IN TWO SECTIONS:  
 PROJECT A: NEW BUILDING TO BRIDGE  
 PROJECT B: BRIDGE TO WATER TREATMENT SYSTEM  
 1.2 WASTE AND OVERFLOW PIPING TO HAVE MIN 0.5% SLOPE

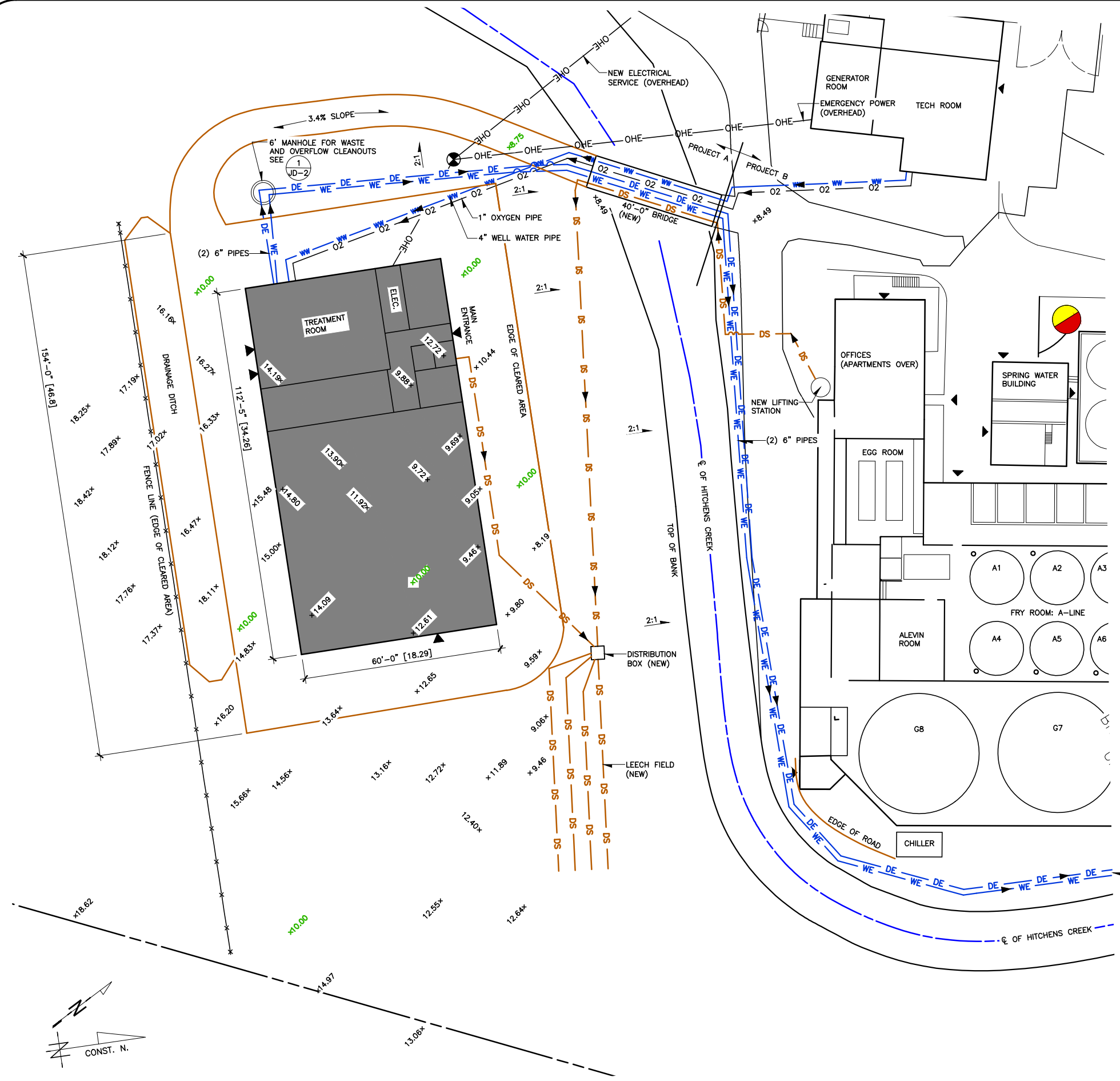

**LEGEND**

- PROPERTY LINE
- CENTER LINE
- TREE LINE
- WELL
- SPRING
- ROB MANN ELEVATION 160623
- FINISHED ELEVATION 160623
- WELL WATER
- WASTE EFFLUENT
- DISCHARGE EFFLUENT
- DOMESTIC SEWAGE
- OXYGEN GAS
- OVER HEAD ELECTRICAL

'PRELIMINARY'  
 'NOT FOR CONSTRUCTION'  
 PRINTED ON: 2017/07/28

**Cooke AQUACULTURE Inc.**

THE DRAWINGS AND ALL OWNERSHIP RIGHTS THEREIN ARE THE SOLE AND EXCLUSIVE PROPERTY OF COOKE AQUACULTURE INC. ANY REPRODUCTION OR USE IN WHOLE OR IN PART BY ANY MEANS BY ANY PERSON WITHOUT THE PRIOR WRITTEN CONSENT OF THE OWNER IS STRICTLY PROHIBITED. THIS IS A CONFIDENTIAL AND PROPRIETARY DOCUMENT.

PROJECT: GENOMICS UNIT  
 LOCATION: OAK BAY, NB  
 TITLE: PLAN - PROJECT AREA

JOB: C15-23	DATE: 17/07/27	REVISED: -	DRAWN: L.T.H.	CHECKED: C.A.I.
-------------	----------------	------------	---------------	-----------------

**sorensen** ENGINEERING LTD.  
 SHEET L-1A  
 134 CARLETON, SAINT ANDREWS, NB E5B 1N9  
 PHONE (506) 529-0093 EMAIL INFO@SORENSEN.CA

**1 OAK BAY HATCHERY SITE PLAN**  
 SCALE 50' TO 1" 11"x17"  
 SCALE 25' TO 1" 22"x 34"

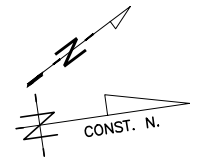



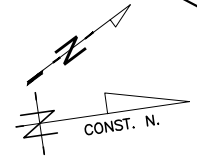
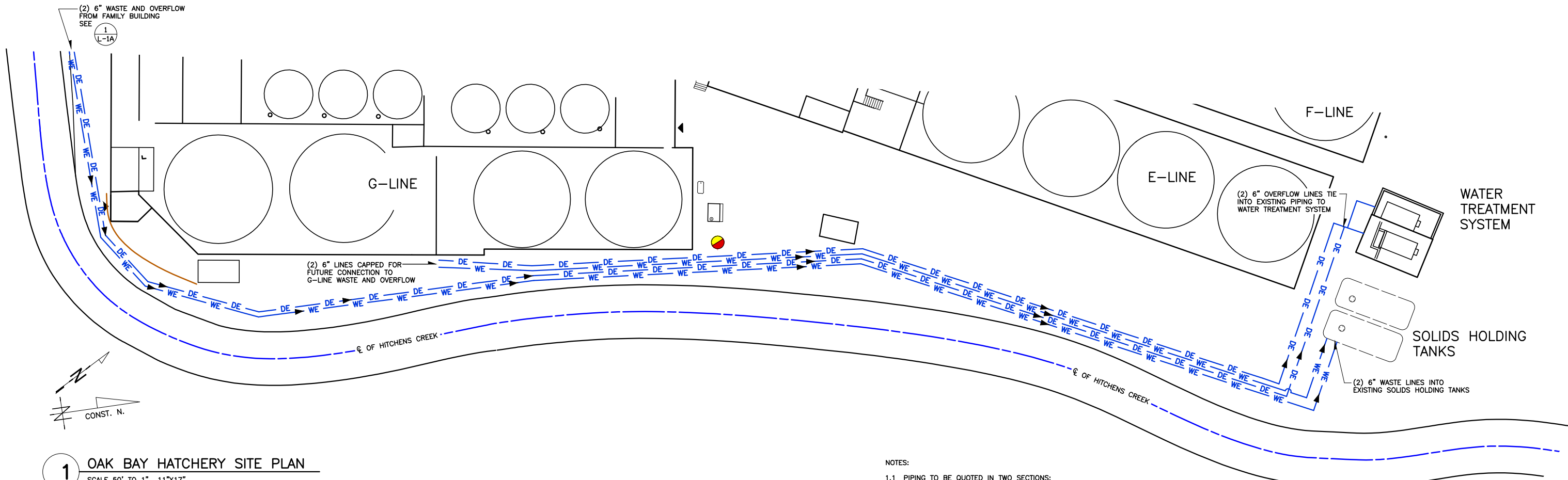

**1 OAK BAY HATCHERY SITE PLAN**  
 SCALE 50' TO 1" 11"x17"  
 SCALE 25' TO 1" 22"x 34"

- NOTES:
- 1.1 PIPING TO BE QUOTED IN TWO SECTIONS:  
 PROJECT A: NEW BUILDING TO BRIDGE  
 PROJECT B: BRIDGE TO WATER TREATMENT SYSTEM
  - 1.2 WASTE AND OVERFLOW PIPING TO HAVE MIN 0.5% SLOPE

'PRELIMINARY'  
 'NOT FOR CONSTRUCTION'

PRINTED ON: 2017/07/28

**LEGEND**

- PROPERTY LINE
- CENTER LINE
- ☁ TREE LINE
- WELL
- ☀ SPRING
- xxx ROB MANN ELEVATION 160623
- xxx FINISHED ELEVATION 160623
- w— WELL WATER
- we— WASTE EFFLUENT
- de— DISCHARGE EFFLUENT
- ds— DOMESTIC SEWAGE
- ds— OXYGEN GAS
- ohe— OVER HEAD ELECTRICAL

**Cooke**  
 AQUACULTURE Inc.

THE DRAWINGS AND ALL OWNERSHIP RIGHTS THEREIN ARE THE SOLE AND EXCLUSIVE PROPERTY OF COOKE AQUACULTURE INC. ANY REPRODUCTION OR USE IN WHOLE OR IN PART BY ANY MEANS BY ANY PERSON WITHOUT THE PRIOR WRITTEN CONSENT OF THE OWNER IS STRICTLY PROHIBITED. THIS IS A CONFIDENTIAL AND PROPRIETARY DOCUMENT.

PROJECT GENOMICS UNIT				
LOCATION OAK BAY, NB				
TITLE PLAN - EFFLUENT CONNECTION				
JOB: C15-23	DATE: 17/07/27	REVISED: -	DRAWN: L.T.H.	CHECKED: C.A.I.

SHEET  
**L-1B**

134 CARLETON, SAINT ANDREWS, NB E5B 1N9  
 PHONE (506) 529-0093 EMAIL INFO@SORENSON.CA

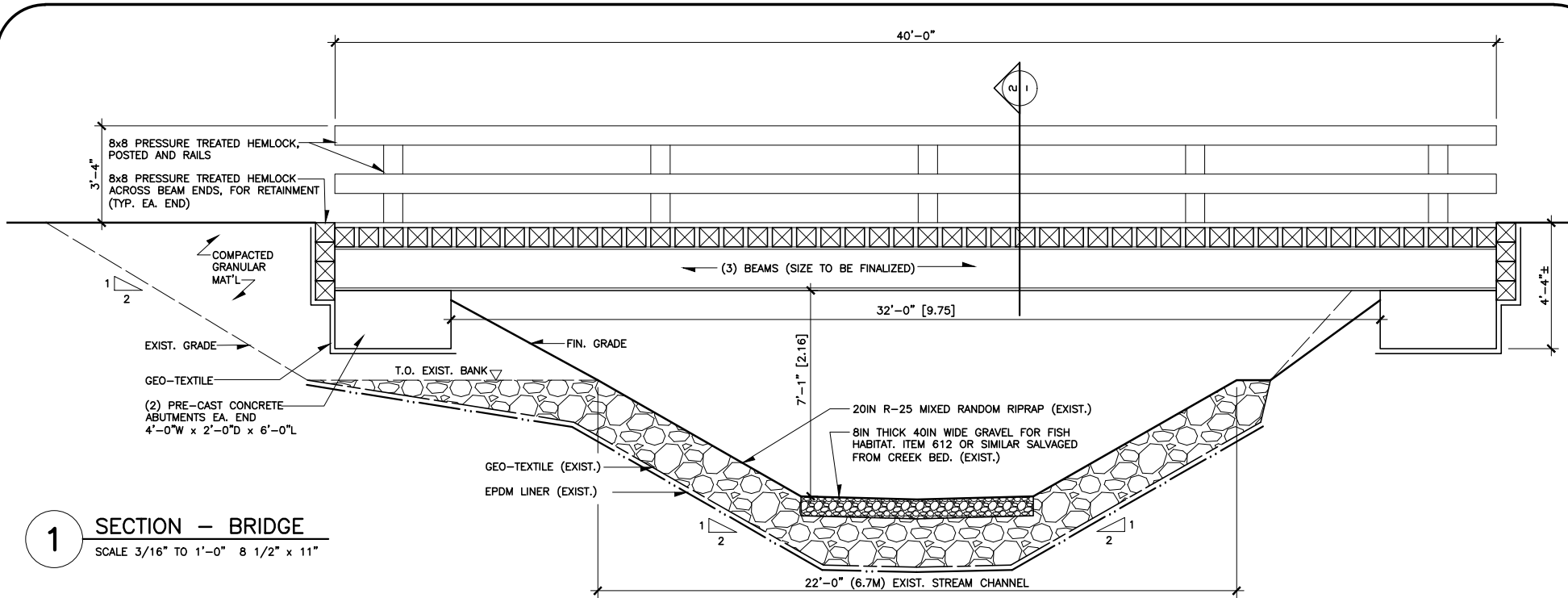

**1 SECTION - BRIDGE**  
 SCALE 3/16" TO 1'-0" 8 1/2" x 11"

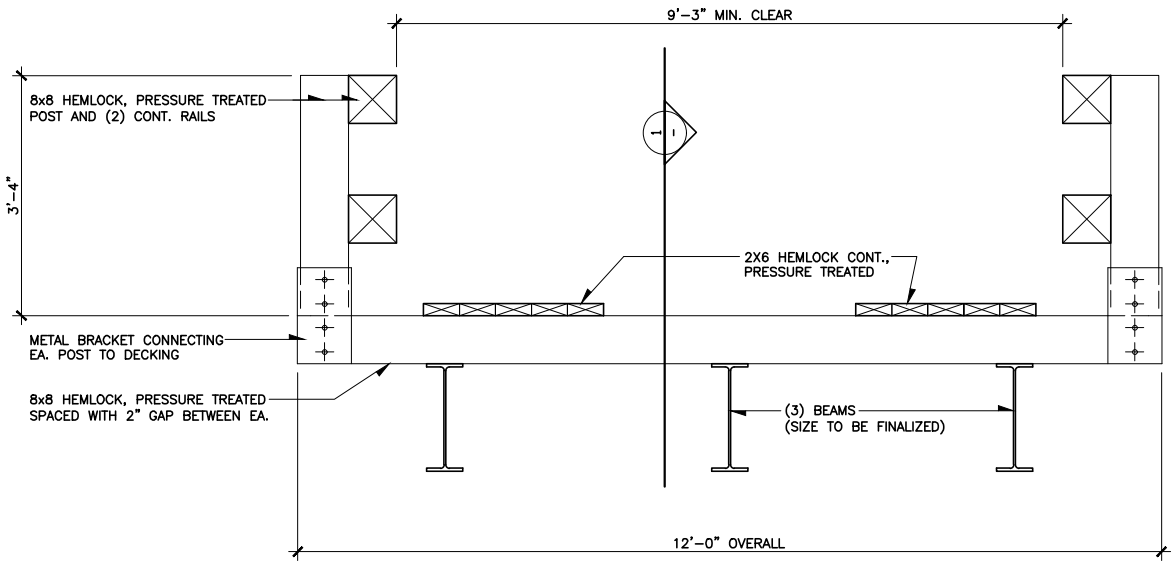

**2 SECTION - BRIDGE**  
 SCALE 3/8" TO 1'-0" 8 1/2" x 11"

'PRELIMINARY'  
 'NOT FOR CONSTRUCTION'  
 PRINTED ON: 2017/07/28



THE DRAWINGS AND ALL OWNERSHIP RIGHTS THEREIN ARE THE SOLE AND EXCLUSIVE PROPERTY OF COOKE AQUACULTURE INC. ANY REPRODUCTION OR USE IN WHOLE OR IN PART BY ANY MEANS BY ANY PERSON WITHOUT THE PRIOR WRITTEN CONSENT OF THE OWNER IS STRICTLY PROHIBITED. THIS IS A CONFIDENTIAL AND PROPRIETARY DOCUMENT.

PROJECT GENOMICS UNIT				
LOCATION OAK BAY, NB				
TITLE BRIDGE DETAILS				
JOB: C15-23	DATE: 16/08/09	REVISED: -	DRAWN: M.D.S.	CHECKED: C.A.I.

**sorensen**  
 ENGINEERING LTD.  
 134 CARLETON, SAINT ANDREWS, NB E5B 1N9  
 PHONE (506) 529-0093 EMAIL INFO@SORENSEN.CA

SHEET  
**L-2**  
 REV. 0

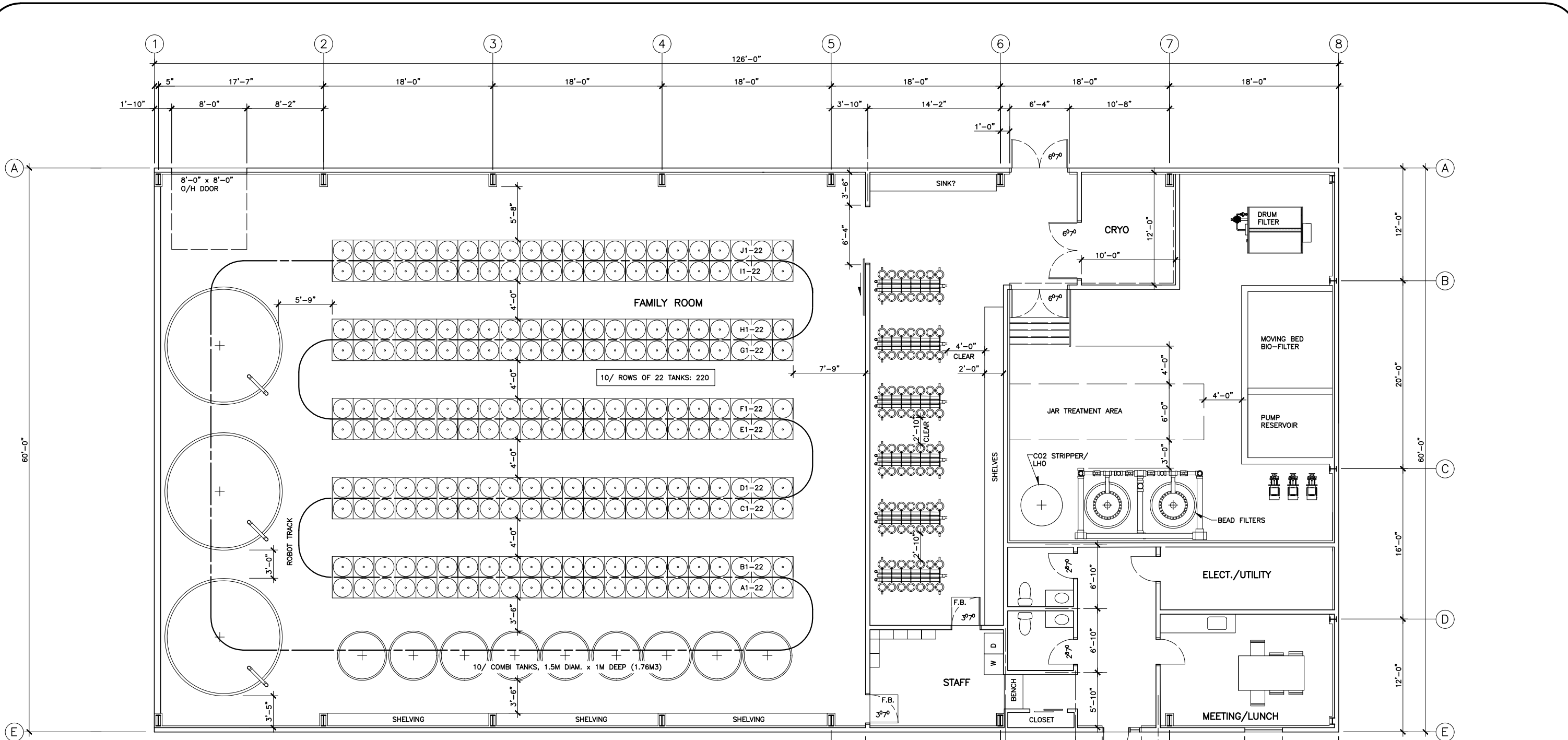

1 PLAN  
 SCALE 3/32" TO 1'-0" 11"x17"  
 SCALE 1/16" TO 1'-0" 22"x34"  
 CONST. N.

3'-8" 22'-4" 7'-5" 8'-9" 19'-3"  
 10'-10" 4'-2" 3'-0" 8'-0" 4'-0" 6'-0"  
 18'-0" 18'-0" 18'-0"  
 54'-0"

'PRELIMINARY'  
 'NOT FOR CONSTRUCTION'

PRINTED ON: 2017/07/28



THE DRAWINGS AND ALL OWNERSHIP RIGHTS THEREIN ARE THE SOLE AND EXCLUSIVE PROPERTY OF COOKE AQUACULTURE INC. ANY REPRODUCTION OR USE IN WHOLE OR IN PART BY ANY MEANS BY ANY PERSON WITHOUT THE PRIOR WRITTEN CONSENT OF THE OWNER IS STRICTLY PROHIBITED. THIS IS A CONFIDENTIAL AND PROPRIETARY DOCUMENT.

PROJECT FAMILY GENOMICS UNIT				
LOCATION OAK BAY HATCHERY				
TITLE PLAN - BUILDING				
JOB: C15-23	DATE: 17/04/27	REVISED: -	DRAWN: M.D.S.	CHECKED: C.A.I.

**sorensen**  
 ENGINEERING LTD.  
 134 CARLETON, SAINT ANDREWS, NB E5B 1N9  
 PHONE (506) 529-0093 EMAIL INFO@SORENENGA.COM

SHEET  
D-2

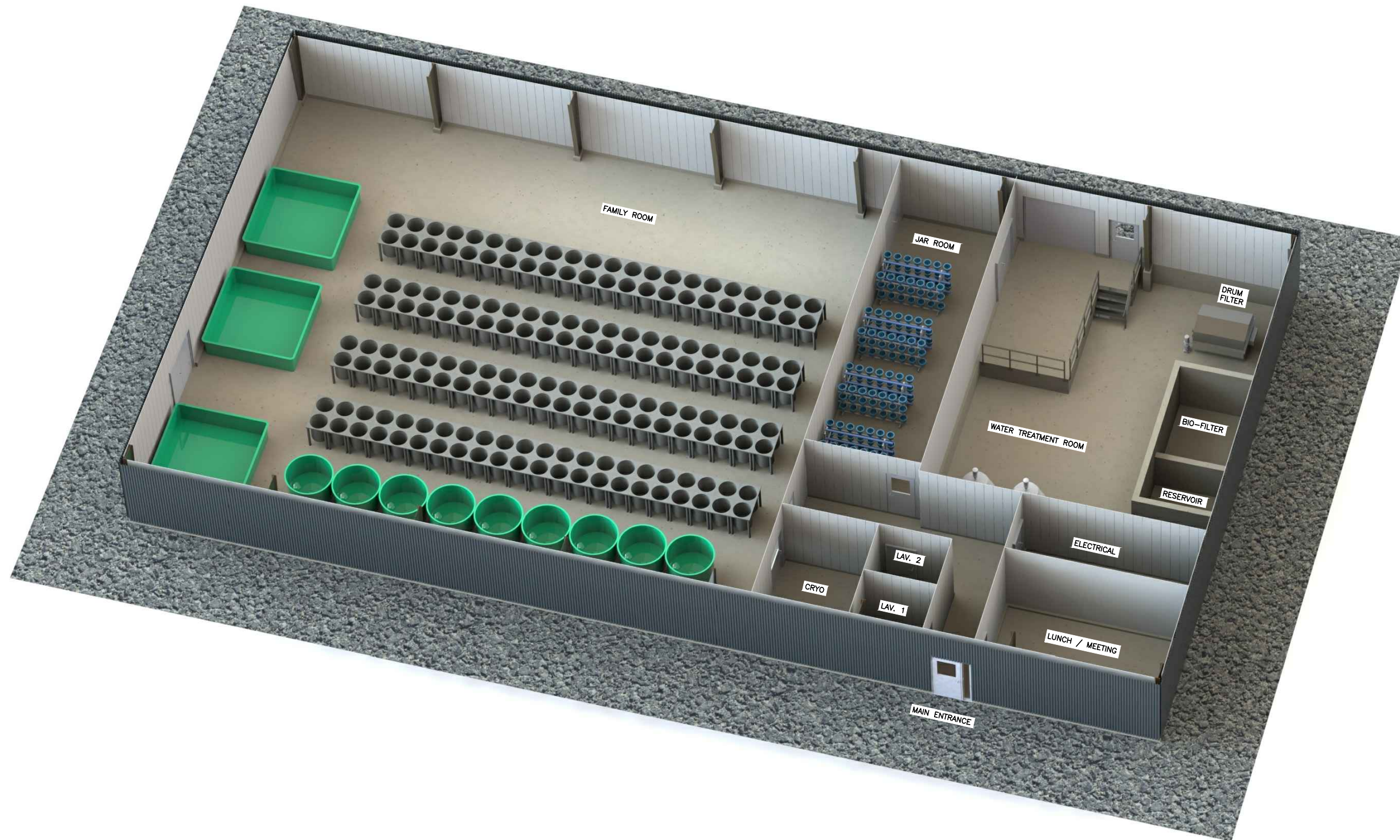

'PRELIMINARY'  
'NOT FOR CONSTRUCTION'

PRINTED ON: 2017/07/28



THE DRAWINGS AND ALL OWNERSHIP RIGHTS THEREIN ARE THE SOLE AND EXCLUSIVE PROPERTY OF COOKE AQUACULTURE INC. ANY REPRODUCTION OR USE IN WHOLE OR IN PART BY ANY MEANS BY ANY PERSON WITHOUT THE PRIOR WRITTEN CONSENT OF THE OWNER IS STRICTLY PROHIBITED. THIS IS A CONFIDENTIAL AND PROPRIETARY DOCUMENT.

PROJECT  
FAMILY GENOMICS UNIT  
LOCATION  
OAK BAY HATCHERY  
TITLE  
RENDERING - NORTH EAST

JOB: C15-23	DATE: 17/03/16	REVISED: -	DRAWN: M.D.S.	CHECKED: C.A.I.
----------------	-------------------	---------------	------------------	--------------------

 **sorensen** ENGINEERING LTD. SHEET R-1  
134 CARLETON, SAINT ANDREWS, NB E5B 1N9  
PHONE (506) 529-0093 EMAIL INFO@SORENGLA

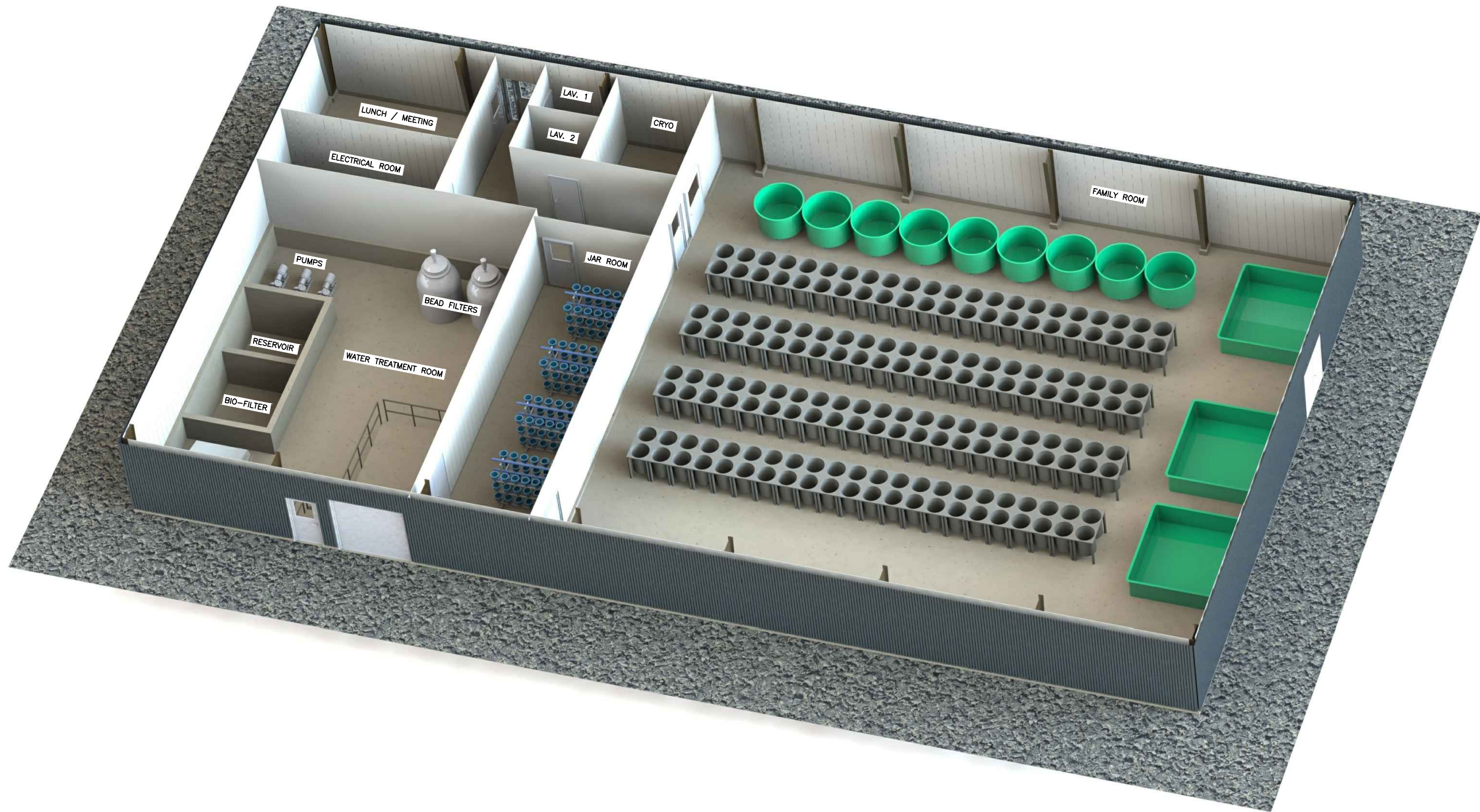

THE DRAWINGS AND ALL OWNERSHIP RIGHTS THEREIN ARE THE SOLE AND EXCLUSIVE PROPERTY OF COOKE AQUACULTURE INC. ANY REPRODUCTION OR USE IN WHOLE OR IN PART BY ANY MEANS BY ANY PERSON WITHOUT THE PRIOR WRITTEN CONSENT OF THE OWNER IS STRICTLY PROHIBITED. THIS IS A CONFIDENTIAL AND PROPRIETARY DOCUMENT.

PROJECT  
 FAMILY GENOMICS UNIT  
 LOCATION  
 OAK BAY HATCHERY  
 TITLE  
 RENDERING - SOUTH WEST

JOB: C15-23	DATE: 17/03/15	REVISED: -	DRAWN: M.D.S.	CHECKED: C.A.I.
----------------	-------------------	---------------	------------------	--------------------

**sorensen**  
 ENGINEERING LTD.  
 134 CARLETON, SAINT ANDREWS, NB E5B 1N9  
 PHONE (506) 529-0093 EMAIL INFO@SORENCA

SHEET  
R-2

'PRELIMINARY'  
 'NOT FOR CONSTRUCTION'

PRINTED ON: 2017/07/28